

# JUMO dTRANS T08 XX

Temperature transmitter series 6 mm

707101, 707102, 707111, 707112, 707113, 707131,  
707133, 707137

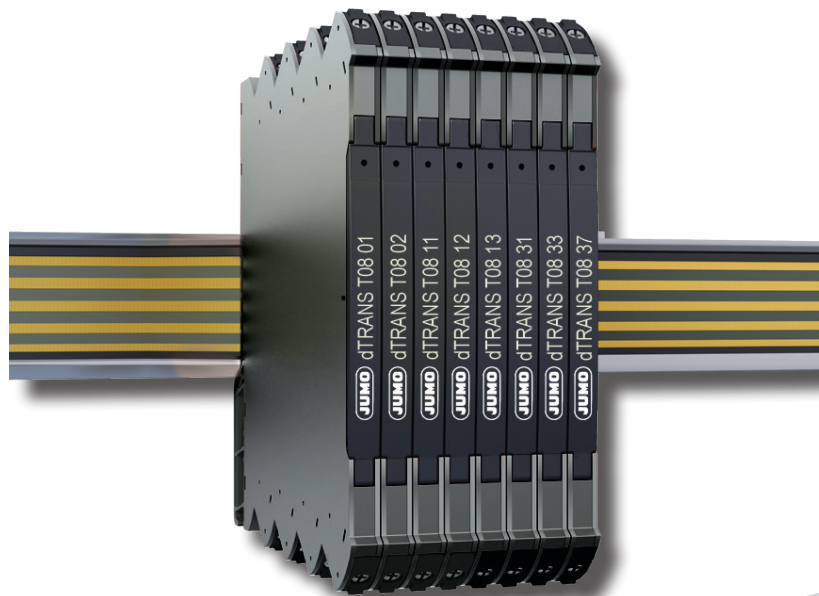

## Operating Manual

70710100T90Z001K000

V1.00/EN/00698632



# Temperature transmitter series 6 mm

JUMO dTRANS T08 01 / JUMO dTRANS T08 02 /  
JUMO dTRANS T08 11 / JUMO dTRANS T08 12 /  
JUMO dTRANS T08 13 / JUMO dTRANS T08 31 /  
JUMO dTRANS T08 33 / JUMO dTRANS T08 37

## Table of contents

Warning .....	3
Symbol identification .....	3
Safety instructions .....	3
UL installation .....	4
IECEX, ATEX installation in Zone 2 .....	4
Flexible supply .....	6
Mounting and demounting of JUMO dTRANS T/S08 .....	7
Installation on DIN rail / power rail .....	8
Supply of power rail .....	8
Marking .....	8
Side label .....	9
Applications .....	10
Technical characteristics .....	10
Mounting / installation .....	10
Order codes .....	11
Accessories .....	11
Accessories for power rail devices .....	11
Technical data .....	11
Connections .....	15
Front led indications .....	16
DIP-switch configuration .....	17
Default configurations .....	17
Temperature range programming .....	18

## Warning



**GENERAL**

To avoid the risk of electric shock and fire, the safety instructions of this guide must be observed and the guidelines followed. The specifications must not be exceeded, and the device must only be applied as described in the following. Prior to the commissioning of the device, this installation guide must be examined carefully. Only qualified personnel (technicians) should install this device. If the equipment is used in a manner not specified by the manufacturer, the protection provided by the equipment may be impaired. Until the device is fixed, do not connect hazardous voltages to the device.



**HAZARDOUS  
VOLTAGE**

**To avoid explosion and serious injury: Modules having mechanical failures must be returned to JUMO GmbH & Co. KG for repair or replacement.**

**Repair of the device must be done by JUMO GmbH & Co. KG only.**

In applications where hazardous voltage is connected to in-/outputs of the device, sufficient spacing or isolation from wires, terminals and enclosure - to surroundings (incl. neighboring devices), must be ensured to maintain protection against electric shock.



**CAUTION**

Potential electrostatic charging hazard. To avoid the risk of explosion due to electrostatic charging of the enclosure, do not handle the units unless the area is known to be safe, or appropriate safety measures are taken to avoid electrostatic discharge.

## Symbol identification



**Triangle with an exclamation mark:** Read the manual before installation and commissioning of the device in order to avoid incidents that could lead to personal injury or mechanical damage.



**The CE mark** proves the compliance of the device with the essential requirements of the directives.



**Ex** devices have been approved acc. to the ATEX directive for use in connection with installations in explosive areas.

## Safety instructions

### Receipt and unpacking

Unpack the device without damaging it and check whether the device type corresponds to the one ordered. The packing should always follow the device until this has been permanently mounted.

### Environment

Avoid direct sun light, dust, high temperatures, mechanical vibrations and shock, and rain and heavy moisture. If necessary, heating in excess of the stated limits for ambient temperatures should be avoided by way of ventilation.

The device can be used for Measurement Category II and Pollution Degree 2.

The device is designed to be safe at least under an altitude up to 2 000 m.

## Mounting

Only technicians who are familiar with the technical terms, warnings, and instructions in the manual and who are able to follow these should connect the device.

Should there be any doubt as to the correct handling of the device, please contact your local distributor or, alternatively,  
**JUMO GmbH & Co. KG**  
**www.jumo.net**

Mounting and connection of the device should comply with national legislation for mounting of electric materials, i.e. wire cross section, protective fuse, and location.

Descriptions of input / output and supply connections are shown in this installation guide and on the side label.

The device is provided with field wiring terminals and shall be supplied from a Power Supply having double / reinforced insulation. A power switch should be easily accessible and close to the device. The power switch shall be marked as the disconnecting unit for the device.

JUMO dTRANS T/S08 must be mounted on a DIN rail according to EN 60715.

### UL installation

Use 60/75°C copper conductors only.

Wire size. . . . . AWG 26-12

UL file number . . . . . E201387

The device is an Open Type Listed Process Control Equipment. To prevent injury resulting from accessibility to live parts the equipment must be installed in an enclosure.

The power supply unit must comply with NEC Class 2, as described by the National Electrical Code® (ANSI / NFPA 70).

### IECEX, ATEX installation in Zone 2

IECEX DEK 18.0006 X . . . . . Ex nA IIC T4 Gc

DEKRA 18ATEX0007 X . . . . . II 3G Ex nA IIC T4 Gc

For safe installation the following must be observed. The device shall only be installed by qualified personnel who are familiar with the national and international laws, directives and standards that apply to this area.

Year of manufacture can be taken from the first two digits in the serial number.

The devices shall be installed in a suitable enclosure providing a degree of protection of at least IP54 according to EN60529, taking into account the environmental conditions under which the equipment will be used.

When the temperature under rated conditions exceeds 70°C at the cable or conduit entry point, or 80°C at the branching point of the conductors, the temperature specification of the selected cable shall be in compliance with the actual measured temperature.

Provisions shall be made to prevent the rated voltage from being exceeded by transient disturbances of more than 40%.

For installation on power rail in Zone 2, only Power rail profile (TN: 00697614) supplied by Power connector unit for dTRANS T/S08 XX (TN: 00697612) is allowed.

To prevent ignition of the explosive atmospheres, disconnect power before servicing and do not separate connectors when energised and an explosive gas mixture is present.

Do not mount or remove devices from the power rail when an explosive gas mixture is present.

### **Cleaning**

When disconnected, the device may be cleaned with a cloth moistened with distilled water.

### **Liability**

To the extent the instructions in this manual are not strictly observed, the customer cannot advance a demand against JUMO GmbH & Co. KG that would otherwise exist according to the concluded sales agreement.

# Flexible supply

The technical specifications specifies the maximum required power at nominal operating values, e.g. 24 V supply voltage, 70°C ambient temperature, 600 Ω load, and 20 mA output current.

## DIN rail solution - device daisy chain:

The JUMO dTRANS T08 01, T08 02, T08 11, T08 12 and T08 13 can be supplied with 24 VDC  $\pm 30\%$  via direct wiring and a loop between the devices.

Protective fuse: 2.5 A.\*

## Power rail solution #2:

The JUMO dTRANS T/S08 PCU power connector unit allows easy connection of a 24 VDC / 2.5 A source to the power rail.

Protective fuse: 2.5 A.\*

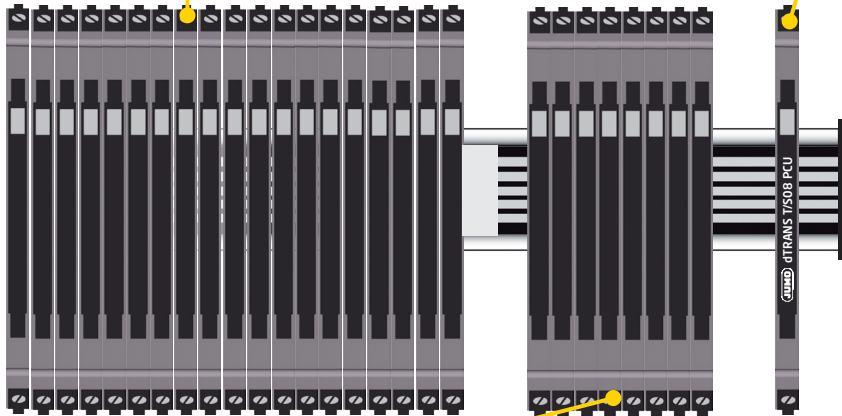

Protective fuse: 0.4 A.

## Power rail solution #1:

Alternately, you can connect 24 VDC to any one JUMO dTRANS T/S08 device with power rail connector which will then energize other units on the rail.

## Note:

Device type JUMO dTRANS T08 01, T08 02, T08 31, T08 33 and T08 37 can only be supplied via the DIN rail solution with direct wiring on each device.

## (\* ) External fuse characteristics:

The 2.5 A fuse must break after not more than 120 seconds at 6.4 A.

## Mounting and demounting of JUMO dTRANS T/S08

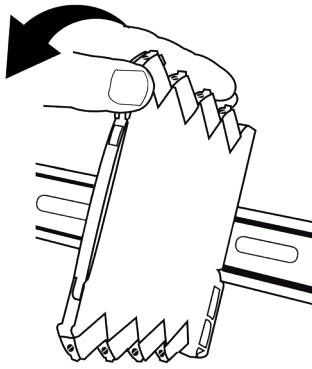

**Picture 1:**  
Mounting on DIN rail / power rail.  
Click the device onto the rail.

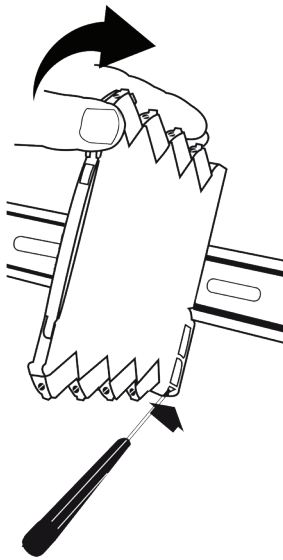

**Picture 2:**  
Demounting from DIN rail / power rail.  
First, remember to demount the connectors with hazardous voltages.  
Detach the device from the DIN rail by lifting the bottom lock.

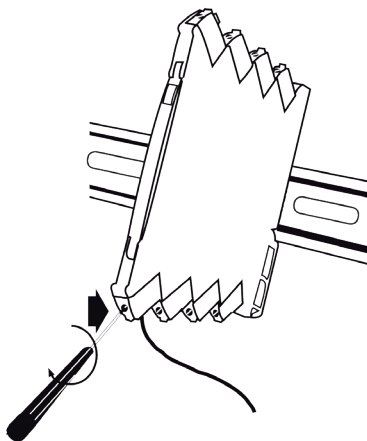

**Picture 3:**  
Wire size AWG 26-12 / 0.13 x 2.5 mm<sup>2</sup> stranded wire.  
Screw terminal torque 0.5 Nm.

## Installation on DIN rail / power rail

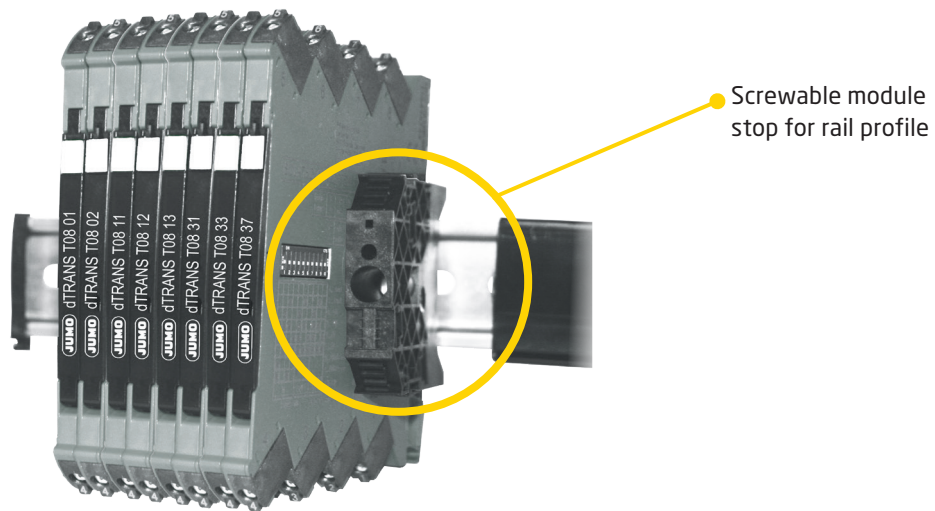

The devices in the JUMO dTRANS T/S08 series can be installed on a DIN rail or on a power rail (only JUMO dTRANS T08 11, T08 12 and T08 13). For marine applications the devices must be supported by a module stop (TN: 00697615). Power supply units can be mounted on the power rail according to customer requirements.

If you want to install a JUMO dTRANS T/S08 device with power rail connectors on a standard DIN rail, the head of the screws holding the 7.5 mm DIN rail shall be no more than 3.5 mm high in order to avoid short circuit between the power rail connectors on the device and the screws.

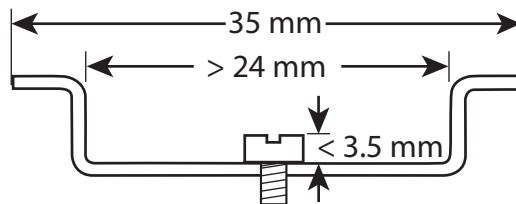

## Supply of power rail

It is possible to supply the power rail via the supply terminals. The terminals can pass a current of max. 400 mA.

## Marking

The front cover of the JUMO dTRANS T/S08 devices has been designed with an area for affixation of a click-on marker. The area assigned to the marker measures 5 x 7.5 mm. Markers from Weidmüller's MultiCard System, type MF 5/7.5, are suitable.

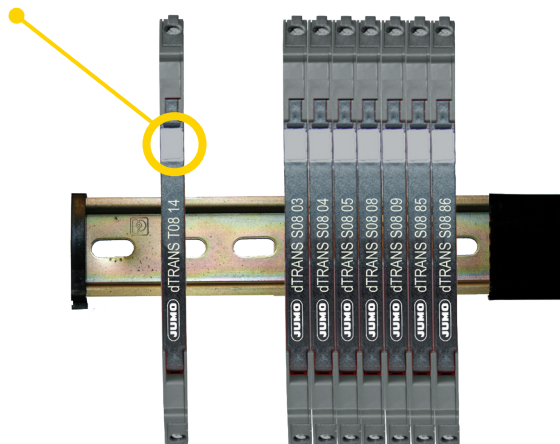



# Side label

**JUMO** JUMO GmbH & Co. KG  
Moritz-Juchheim-Straße 1  
38039 Fulda, Germany  
www.jumo.net

**HART®** transmitter (Pt100, J, K)

**HART REGISTERED**

1 S1 10 1 S2 10 On

**JUMO dTRANS T08 13**  
707113  
TN: 00697472

**IECEx** Ex nA IIC T4 Gc  
IECEx DEK 18.0006X

**Ex** II 3 G Ex nA IIC T4 Gc  
DEKRA 18ATEX0007X

**UL LISTED** OPEN-TYPE PROCESS CONTROL EQUIPMENT  
E201387

-25°C < Ta < +70°C

123456789

DNV-GL

CE

Power Rail

+2w	+3w	+4w	CJC-	TC+	4	5	→ Out	mA+
-2w	-3w	-4w	CJC-	TC-	3	6	→ Out	mA-
			CJC+		2	7	Supply+	24 V ±30%
			CJC+		1	8	Supply-	0.7 W

Sensor	S1	1	2	3
Pt100, 2w	●	●	●	●
Pt100, 3w	●	●	●	●
Pt100, 4w	●	●	●	●
TC J (Int. CJC)	●	●	●	●
TC K (Int. CJC)	●	●	●	●
TC J (Ext. CJC)	●	●	●	●
TC K (Ext. CJC)	●	●	●	●

Sensor Error Detection	S1	7
None		●
Enable		●

Output Error Level	S1	8
Downscale		●
Upscale		●

Noise Supp.	S1	9	Config.	S1	10
50 Hz		●	DIP		●
60 Hz		●	HART		●

Output	S1	4	5	6
4...20 mA	●	●	●	●
20...4 mA	●	●	●	●

● = ON

## Temperature transmitter series 6 mm

**JUMO dTRANS T08 01 / JUMO dTRANS T08 02 / JUMO dTRANS T08 11 /  
JUMO dTRANS T08 12 / JUMO dTRANS T08 13 / JUMO dTRANS T08 31 /  
JUMO dTRANS T08 33 / JUMO dTRANS T08 37**

- Converts process measurements from Pt100, TC J and K temperature sensors to voltage or current outputs
- Multiple pre-calibrated temperature ranges are selectable via DIPswitches
- High accuracy, better than 0.05% and excellent 50/60 Hz noise suppression
- Fast signal response time < 30 ms
- JUMO dTRANS T08 13 and T08 37 with HART 7 protocol and fast signal response time < 60 ms
- HART 7 protocol enables extended device programming for JUMO dTRANS T08 13 and T08 37
- Slimline 6 mm housing

### Applications

- The temperature converters measure standard 2-, 3- or 4-wire Pt100 and/or TC J & K temperature sensors, and provides an analog voltage or current output.
- High 3 port isolation provides surge suppression and protects the control system from transients and noise.
- The loop powered devices have high 2-port galvanic separation to eliminate ground loops.
- The devices can be mounted in the Safe area or in Zone 2 / Division 2 areas.
- Approved for marine applications.

### Technical characteristics

- High conversion accuracy, better than 0.05% of span.
- A visible green LED indicates operational status and status of the input sensor.
- All terminals are protected against overvoltage and polarity error.
- Meeting the NAMUR NE21 recommendations, the system JUMO dTRANS T/S08 devices ensure top measurement performance in harsh EMC environments.
- The devices meet the NAMUR NE43 standard defining out of range and sensor error output values.
- High galvanic isolation of 2.5 kVAC.
- Excellent signal/noise ratio of > 60 dB.

### Mounting / installation

- Selectable DIP-mode for easy configuration of more than 1000 factory calibrated measurement ranges with HART read only feature.
- The narrow 6 mm housing and very low power consumption allows up to 165 units to be mounted per meter of DIN rail, without any air gap between units.
- Wide temperature operation range of -25...+70°C.

## Order codes

	Input				Output			LED	Supply	Isolated	HART
	TC			Pt100	Current		Voltage				
	J & K	Int. CJC	Ext. CJC	2-, 3-, 4-wire	Active	Passive					
JUMO dTRANS T08 01	✓	✓			✓		✓	✓	24 VDC		
JUMO dTRANS T08 02				✓	✓		✓	✓	24 VDC		
JUMO dTRANS T08 11	✓	✓	✓		✓		✓	✓	24 VDC / power rail	2.5 kV	
JUMO dTRANS T08 12				✓	✓		✓	✓	24 VDC / power rail	2.5 kV	
JUMO dTRANS T08 13	✓	✓	✓	✓	✓			✓	24 VDC / power rail	2.5 kV	✓
JUMO dTRANS T08 31	✓	✓	✓	✓		✓			Loop-powered	2.5 kV	
JUMO dTRANS T08 33				✓		✓			Loop-powered		
JUMO dTRANS T08 37	✓	✓	✓	✓		✓			Loop-powered	2.5 kV	✓

## Accessories

TN: 00697615 = Screwable module stop for rail profile

## Accessories for power rail devices

TN: 00697612 = Power connector unit for JUMO dTRANS T/S08 XX

TN: 00697614 = Power rail profile (7.5 mm / 750 mm)

## Technical data

### Environmental conditions:

Operating temperature . . . . . -25°C to +70°C  
 Storage temperature . . . . . -40°C to +85°C  
 Calibration temperature. . . . . 20...28°C  
 Relative humidity . . . . . < 95% RH (non-cond.)  
 Protection degree . . . . . IP20  
 Installation in pollution degree 2 & overvoltage category II.

### Mechanical specifications:

Dimensions (HxWxD) . . . . . 113 x 6.1 x 115 mm  
 Weight approx. . . . . 70 g  
 DIN rail type. . . . . DIN EN 60715 - 35 mm  
 Wire size. . . . . 0.13...2.5 mm<sup>2</sup> / AWG 26...12 stranded wire  
 Screw terminal torque. . . . . 0.5 Nm  
 Vibration. . . . . IEC 60068-2-6  
 2...25 Hz. . . . . ±1.6 mm  
 25...100 Hz. . . . . ±4 g

**Common electrical specifications:**

Supply voltage, 24 VDC nom. . . . . 16.8...31.2 VDC

Loop-powered:

JUMO dTRANS T08 31 . . . . . 5.5...35 VDC

JUMO dTRANS T08 33 . . . . . 3.3...35 VDC

JUMO dTRANS T08 37 . . . . . 6.2...35 VDC

Power requirements:

Type	Max. power dissipation	Max. required power
JUMO dTRANS T08 01	0.52	0.52
JUMO dTRANS T08 02	0.52	0.52
JUMO dTRANS T08 11	0.70	0.70
JUMO dTRANS T08 12	0.70	0.70
JUMO dTRANS T08 13	0.70	0.70
JUMO dTRANS T08 31	0.80	0.80
JUMO dTRANS T08 33	0.80	0.80
JUMO dTRANS T08 37	0.80	0.80

Max. required power is the maximum power needed at power supply terminals or rail connector.

Max. power dissipation is the maximum power dissipated at nominal operating values.

Isolation voltage, test . . . . . 2.5 kVAC

Isolation voltage working. . . . . 300 VAC (reinforced) /  
250 VAC (Zone 2, Div. 2)

Double isolation . . . . . Input / output 1 / output 2 / supply

Signal dynamics, input . . . . . 23 bit

Signal dynamics, output . . . . . 18 bit

Signal / noise ratio . . . . . Min. 60 dB

	Response time			
	Selectable		HART read only mode	HART mode
	< 30 ms	< 300 ms	< 60 ms	0.06..60 s
JUMO dTRANS T08 01	✓	✓		
JUMO dTRANS T08 02	✓	✓		
JUMO dTRANS T08 11	✓	✓		
JUMO dTRANS T08 12	✓	✓		
JUMO dTRANS T08 13			✓	✓
JUMO dTRANS T08 31	✓	✓		
JUMO dTRANS T08 33	✓	✓		
JUMO dTRANS T08 37			✓	✓

Incorrect DIP-sw setting identification:

Supplied. . . . . 0 V / 0 mA output; LED 0.5 s / 1 Hz

Loop-powered . . . . . 3.5 mA output

Device	Input	Basic accuracy	General accuracy	Temperature coefficient
JUMO dTRANS T08 12, JUMO dTRANS T08 13, JUMO dTRANS T08 31, JUMO dTRANS T08 37	Pt100	$\leq 0.1^{\circ}\text{C}$	$\leq \pm 0.05\%$ of span	$0.02^{\circ}\text{C}/^{\circ}\text{C}$ (basic) or $\leq \pm 0.01\%$ of span / $^{\circ}\text{C}$
JUMO dTRANS T08 11, JUMO dTRANS T08 13, JUMO dTRANS T08 31, JUMO dTRANS T08 37	TC	$\leq 0.5^{\circ}\text{C}$		$0.1^{\circ}\text{C}/^{\circ}\text{C}$ (basic) or $\leq \pm 0.01\%$ of span / $^{\circ}\text{C}$
JUMO dTRANS T08 02, JUMO dTRANS T08 33	Pt100	$\leq 0.2^{\circ}\text{C}$	$\leq \pm 0.1\%$ of span	$0.02^{\circ}\text{C}/^{\circ}\text{C}$ (basic) or $\leq \pm 0.01\%$ of span / $^{\circ}\text{C}$
JUMO dTRANS T08 01	TC	$\leq 1^{\circ}\text{C}$		$0.1^{\circ}\text{C}/^{\circ}\text{C}$ (basic) or $\leq \pm 0.01\%$ of span / $^{\circ}\text{C}$

EMC immunity influence . . . . .  $< \pm 0.5\%$  of span

Extended EMC immunity:

NAMUR NE 21 . . . . .  $< \pm 1\%$  of span

**Input specifications:**

**Specifications for Pt100 input:**

Temperature range, Pt100 . . . . .  $-200\dots+850^{\circ}\text{C}$  - IEC 60751

Min. measuring range (span) . . . . .  $10^{\circ}\text{C}$

Sensor current . . . . .  $< 150 \mu\text{A}$

Sensor cable resistance . . . . .  $< 50 \Omega$  per wire

Effect of sensor cable resistance, 3- / 4-wire . . . . .  $< 0.002 \Omega / \Omega$

Sensor error detection . . . . . Yes - selectable via DIP-switch

Broken sensor detection . . . . .  $> 800 \Omega$

Shorted sensor detection . . . . .  $< 18 \Omega$

**Specifications for TC input:**

Temperature range, TC J . . . . .  $-100\dots+1200^{\circ}\text{C}$  - IEC 60584-1

Min. measuring range (span) . . . . .  $50^{\circ}\text{C}$

Temperature range, TC K . . . . .  $-180\dots+1372^{\circ}\text{C}$  - IEC 60584-1

Min. measuring range (span) . . . . .  $50^{\circ}\text{C}$

Sensor cable resistance . . . . .  $< 5 \text{ k}\Omega$  per wire

Cold junction compensation (CJC) accuracy:

Accuracy @ external Pt100 . . . . . Better than  $\pm 0.15^{\circ}\text{C}$

Accuracy @ internal CJC . . . . . Better than  $\pm 2.5^{\circ}\text{C}$

Open Thermocouple detection . . . . . Yes - selectable via DIP-switch

Internal CJC error detection . . . . . Yes

External CJC error detection . . . . . Yes - selectable via DIP-switch

**Output specifications:**

	Current output							
	Active	Passive	Selectable			NAMUR NE43		Max. load
			Invert	Range	Limit	Sensor error	Range 4...20 mA	
JUMO dTRANS T08 01	✓			0/4...20 mA	0/3.8...20.5 mA	0/3.5/23 mA	✓	≤ 600 Ω
JUMO dTRANS T08 02	✓			0/4...20 mA	0/3.8...20.5 mA	0/3.5/23 mA	✓	≤ 600 Ω
JUMO dTRANS T08 11	✓			0/4...20 mA	0/3.8...20.5 mA	0/3.5/23 mA	✓	≤ 600 Ω
JUMO dTRANS T08 12	✓			0/4...20 mA	0/3.8...20.5 mA	0/3.5/23 mA	✓	≤ 600 Ω
JUMO dTRANS T08 13	✓			4...20 mA	0/3.8...20.5 mA	0/3.5/23 mA	✓	≤ 600 Ω
JUMO dTRANS T08 31		✓	✓	4...20 mA	3.8...20.5 mA	3.5 / 23 mA	✓	$(V_{\text{supply}}-5.5)/0.023$ [Ω]
JUMO dTRANS T08 33		✓	✓	4...20 mA	3.8...20.5 mA	3.5 / 23 mA	✓	$(V_{\text{supply}}-3.3)/0.023$ [Ω]
JUMO dTRANS T08 37		✓	✓	4...20 mA	3.8...20.5 mA	3.5 / 23 mA	✓	$(V_{\text{supply}}-6.2)/0.023$ [Ω]

Updating time . . . . . 10 ms

Load stability . . . . . ≤ 0.01% of span / 100 Ω

	Selectable voltage output						
	Low range			High range			Min. load
	Range	Limit	Sensor error	Range	Limit	Sensor error	
JUMO dTRANS T08 01 JUMO dTRANS T08 02 JUMO dTRANS T08 11 JUMO dTRANS T08 12	0/1...5 V	0/0.875...5.125 V	0/5.5 V	0/2...10 V	0/1.75...10.25 V	0/11 V	10 kΩ

of span = of the selected range

**Observed authority requirements:**

EMC . . . . . 2014/30/EU  
 EMC Emission . . . . . CISPR 22, Class B  
 LVD . . . . . 2014/35/EU  
 RoHS . . . . . 2011/65/EU

**Approvals:**

DNV-GL, Ships & Offshore . . . . . DNVGL-CG-0339  
 UL, Standard for Safety . . . . . UL 61010-1  
 Safe Isolation . . . . . EN 61140

**I.S. / Ex approvals:**

ATEX 2014/34/EU . . . . . DEKRA 18ATEX0007 X  
 IECEx . . . . . DEK 18.0006 X

# Connections

## Input wiring

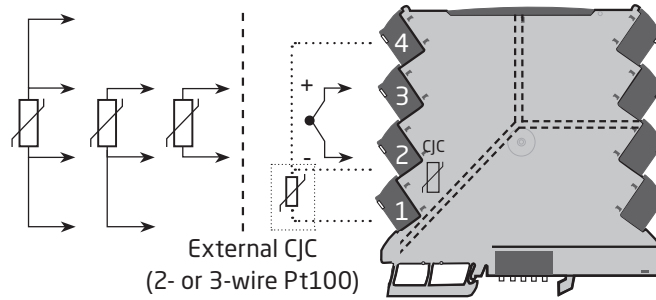

			+	-	CJC	Type
-	-	-	3	2	Y*	JUMO dTRANS T08 01
1,2 & 3,4	1,2 & 3	2 & 3	-	-	N	JUMO dTRANS T08 02
-	-	-	3	2	Y	JUMO dTRANS T08 11
1,2 & 3,4	1,2 & 3	2 & 3	-	-	N	JUMO dTRANS T08 12
1,2 & 3,4	1,2 & 3	2 & 3	3	2	Y	JUMO dTRANS T08 13
1,2 & 3,4	1,2 & 3	2 & 3	3	2	Y	JUMO dTRANS T08 31
1,2 & 3,4	1,2 & 3	2 & 3	-	-	N	JUMO dTRANS T08 33
1,2 & 3,4	1,2 & 3	2 & 3	3	2	Y	JUMO dTRANS T08 37

\*JUMO dTRANS T08 01 - only internal CJC

## Output wiring

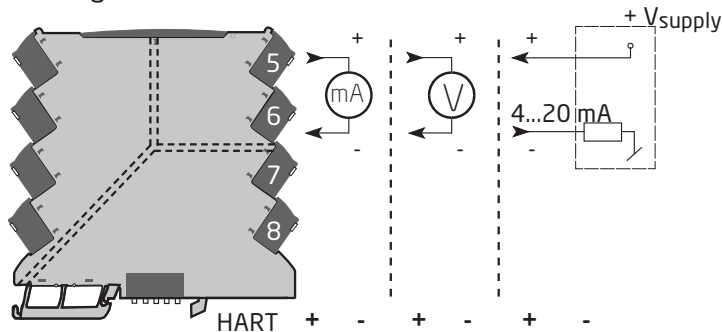

JUMO dTRANS T08 01	N	5	6	5	6	-	-
JUMO dTRANS T08 02	N	5	6	5	6	-	-
JUMO dTRANS T08 11	N	5	6	5	6	-	-
JUMO dTRANS T08 12	N	5	6	5	6	-	-
JUMO dTRANS T08 13	Y	5	6	-	-	-	-
JUMO dTRANS T08 31	N	-	-	-	-	5	6
JUMO dTRANS T08 33	N	-	-	-	-	5	6
JUMO dTRANS T08 37	Y	-	-	-	-	5	6
JUMO dTRANS T/S08 PCU	N	-	-	-	-	-	-

## Supply wiring

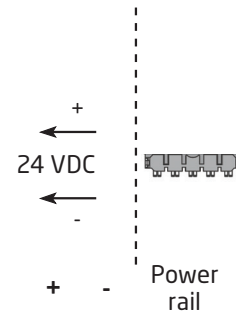

7	8	N
7	8	N
7	8	Y
7	8	Y
7	8	Y
-	-	N
-	-	N
-	-	N
7	8	Y

JUMO dTRANS T08 01, JUMO dTRANS T08 02 and JUMO dTRANS T08 33: No galvanic isolation  
 JUMO dTRANS T08 31 and JUMO dTRANS T08 37: 2 port isolation (reinforced)  
 JUMO dTRANS T08 11, JUMO dTRANS T08 12 and JUMO dTRANS T08 13: 3 port isolation (reinforced)

## Front led indications

For JUMO dTRANS T08 01, JUMO dTRANS T08 02, JUMO dTRANS T08 11,  
JUMO dTRANS T08 12 and JUMO dTRANS T08 13

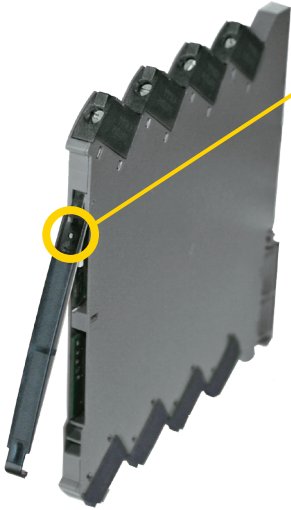

The device is equipped with a green power LED in the front to indicate the operation status, see the table below.

Condition	LED	Output	Action required
No supply / device error	OFF	De-energized	Connect supply / replace device
Power-up or restart	1 Flash (0.5 s OFF + 0.5 s ON)	De-energized	-
Device OK	Flashing 13 Hz (15 ms ON)	Energized	-
Incorrect DIP-switch setting	Flashing 1 Hz (500 ms ON)	De-energized	Correct setting and re-power device
Sensor error indication	Flashing 1 Hz (15 ms ON)	Up- or Downscale	Check sensor



# DIP-switch configuration

The devices can be configured via DIP-switches. The DIP-switches are located on the side of the device and can be adjusted with a small screwdriver or other implement.

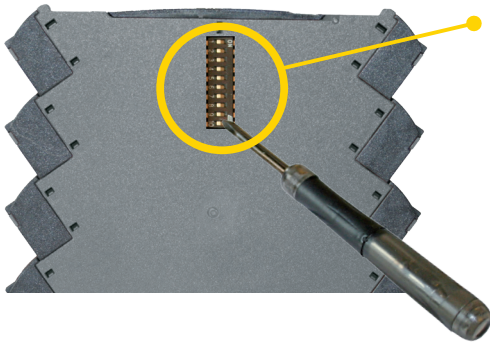

## Default configurations

	JUMO dTRANS T08 02, JUMO dTRANS T08 12, JUMO dTRANS T08 31, JUMO dTRANS T08 33	JUMO dTRANS T08 01, JUMO dTRANS T08 11	JUMO dTRANS T08 13, JUMO dTRANS T08 37
Sensor type	Pt100, 3 wire	TC K (int. CJC)	Pt100, 3 wire
Output range	4...20 mA	4...20 mA	4...20 mA
Error detection	Short circuit detection Broken circuit detection	Short circuit detection	Short circuit detection Broken circuit detection
Error output current	3.5 mA	3.5 mA	3.5 mA
Noise suppression	50 Hz	50 Hz	50 Hz
Input lower limit	0°C	0°C	0°C
Input upper limit	150°C	600°C	150°C
Response time	< 30 ms	< 30 ms	< 60 ms
Configuration mode	-	-	DIP switch configuration

### JUMO dTRANS T08 01 and JUMO dTRANS T08 11 TC J & K

Sensor S1 1 2 3	Sensor Error Detection S1 7
TC J (int. cjc) ●●●	None
TC K (int. cjc) ●●●	Enable ●
TC J (ext. cjc) ●●●	
TC K (ext. cjc) ●●●	
Output S1 4 5 6	Output Error Level S1 8
0...20 mA ●●●	Downscale
4...20 mA ●●●	Upscale ●
0...10 V ●●●	Noise Supp.S1 9
2...10 V ●●●	50 Hz
0...5 V ●●●	60 Hz ●
1...5 V ●●●	Resp.T. S1 10
	< 30 ms
	300 ms ●

\*JUMO dTRANS T08 01 - only int CJC

● = ON

### JUMO dTRANS T08 02 and JUMO dTRANS T08 12 Pt100

Sensor S1 1 2 3	Sensor Error Detection S1 7
Pt100, 2w ●●●	None
Pt100, 3w ●●●	Enable ●
Pt100, 4w ●●●	
Output S1 4 5 6	Output Error Level S1 8
0...20 mA ●●●	Downscale
4...20 mA ●●●	Upscale ●
0...10 V ●●●	Noise Supp.S1 9
2...10 V ●●●	50 Hz
0...5 V ●●●	60 Hz ●
1...5 V ●●●	Resp.T. S1 10
	< 30 ms
	300 ms ●

● = ON

### JUMO dTRANS T08 13 and JUMO dTRANS T08 37 Pt100 & TC J/K + HART

Sensor S1 1 2 3	Sensor Error Detection S1 7
Pt100, 2w ●●●	None
Pt100, 3w ●●●	Enable ●
Pt100, 4w ●●●	
TC J (int. CJC) ●●●	Output Error Level S1 8
TC K (int. CJC) ●●●	Downscale
TC J (Ext. CJC) ●●●	Upscale ●
TC K (Ext. CJC) ●●●	Noise Supp.S1 9
	50 Hz
	60 Hz ●
Output S1 4 5 6	Config. S1 10
4...20 mA ●●●	DIP
20...4 mA ●●●	HART ●

● = ON

### JUMO dTRANS T08 31 Pt100 & TC J/K

Sensor S1 1 2 3	Sensor Error Detection S1 7
Pt100, 2w ●●●	None
Pt100, 3w ●●●	Enable ●
Pt100, 4w ●●●	
TC J (int. CJC) ●●●	Output Error Level S1 8
TC K (int. CJC) ●●●	Downscale
TC J (Ext. CJC) ●●●	Upscale ●
TC K (Ext. CJC) ●●●	Noise Supp.S1 9
	50 Hz
	60 Hz ●
Output S1 4 5 6	Resp.T. S1 10
4...20 mA ●●●	< 30 ms
20...4 mA ●●●	300 ms ●

● = ON

### JUMO dTRANS T08 33 Pt100

Sensor S1 1 2 3	Sensor Error Detection S1 7
Pt100, 2w ●●●	None
Pt100, 3w ●●●	Enable ●
Pt100, 4w ●●●	
Output S1 4 5 6	Output Error Level S1 8
4...20 mA ●●●	Downscale
20...4 mA ●●●	Upscale ●
	Noise Supp.S1 9
	50 Hz
	60 Hz ●
	Resp.T. S1 10
	< 30 ms
	300 ms ●

● = ON

(Power must be cycled after DIP-switch positions are changed).

## Temperature range programming

DIP S2				● = ON						Temperature Range °C															
Start Temp.	1	2	3	4	End Temp.	5	6	7	8	9	10	End Temp.	5	6	7	8	9	10	End Temp.	5	6	7	8	9	10
-200					0							105		●		●		●	375		●		●		●
-180				●	5						●	110		●		●	●		400		●		●		●
-150			●		10						●	115		●		●	●		450		●		●		●
-100			●	●	15						●	120		●	●				500		●		●		●
-50		●			20					●		125		●	●			●	550		●		●		●
-25		●	●		25					●	●	130		●	●			●	600		●		●		●
-10		●	●		30					●	●	135		●	●			●	650		●		●		●
-5		●	●	●	35					●	●	140		●	●			●	700		●		●		●
0	●				40				●			145		●	●	●		●	750		●		●		●
5	●	●			45				●		●	150		●	●	●		●	800		●		●		●
10	●	●	●		50				●		●	160		●	●	●		●	850		●		●		●
20	●	●	●	●	55				●		●	170	●					●	900		●		●		●
25	●	●	●		60				●	●		180	●					●	950		●		●		●
50	●	●	●	●	65				●	●	●	190	●				●	1000		●		●		●	●
100	●	●	●	●	70				●	●	●	200	●				●	1050		●		●		●	●
200	●	●	●	●	75				●	●	●	225	●				●	1100		●		●		●	●
					80		●					250	●				●	1150		●		●		●	●
					85		●			●		275	●			●	●	1200		●		●		●	●
					90		●			●		300	●			●	●	1250		●		●		●	●
					95		●			●	●	325	●		●			1300		●		●		●	●
					100		●	●				350	●	●			●	1350		●		●		●	●
																			1372		●		●		●

Sens. type :	Temp. range °C :
Pt100	-200 - +850°C
TC J	-100 - +1200°C
TC K	-180 - +1372°C

Please note:

- JUMO dTRANS T08 01 and JUMO dTRANS T08 11 - only TC input available  
Valid TC J range: -100...+1200°C = correct DIP-switch setting  
Valid TC K range: -180...+1372°C = correct DIP-switch setting
- JUMO dTRANS T08 02, JUMO dTRANS T08 12 and JUMO dTRANS T08 33 - only Pt100 input available  
Valid Pt100 range: -200...+850°C = correct DIP-switch setting
- "Start temp" must be lower than "End temp" = correct DIP-switch setting
- Power must be cycled after DIP-switch positions are changed



**JUMO GmbH & Co. KG**

Street address:

Moritz-Juchheim-Straße 1  
36039 Fulda, Germany

Delivery address:

Mackenrodtstraße 14  
36039 Fulda, Germany

Postal address:

36035 Fulda, Germany  
Phone: +49 661 6003-0  
Fax: +49 661 6003-607  
Email: [mail@jumo.net](mailto:mail@jumo.net)  
Internet: [www.jumo.net](http://www.jumo.net)

**JUMO Instrument Co. Ltd.**

JUMO House

Temple Bank, Riverway  
Harlow, Essex, CM20 2DY, UK

Phone: +44 1279 63 55 33

Fax: +44 1279 62 50 29

Email: [sales@jumo.co.uk](mailto:sales@jumo.co.uk)

Internet: [www.jumo.co.uk](http://www.jumo.co.uk)

**JUMO Process Control, Inc.**

6733 Myers Road  
East Syracuse, NY 13057, USA

Phone: +1 315 437 5866

Fax: +1 315 437 5860

Email: [info.us@jumo.net](mailto:info.us@jumo.net)

Internet: [www.jumousa.com](http://www.jumousa.com)

