



POWERFLUX 5000 **Technical Datasheet**

Electromagnetic flowmeter in sandwich version

- Exceptional long-term stability and accuracy
- Designed and tested for nuclear environments
- With high-tech ceramics liner



The documentation is only complete when used in combination with the relevant documentation for the signal converter.

1	Product features	3
<hr/>		
1.1	Solution with high-tech ceramics	3
1.2	Options	5
1.3	Measuring principle.....	6
2	Technical data	7
<hr/>		
2.1	Technical data.....	7
2.2	Measurement accuracy	11
2.3	Dimensions and weights	12
3	Installation	15
<hr/>		
3.1	Intended use	15
3.2	General notes on installation	15
3.2.1	Vibration	15
3.2.2	Magnetic field.....	15
3.3	Installation conditions	16
3.3.1	Inlet and outlet	16
3.3.2	Bends in 2 or 3 dimensions.....	16
3.3.3	T-section	17
3.3.4	Bends	17
3.4	Open feed or discharge	18
3.5	Flange deviation	18
3.6	Pump.....	18
3.7	Control valve	19
3.8	Air venting and vacuum forces.....	19
3.9	Mounting position	20
3.10	Mounting	20
3.10.1	Torques and pressure.....	20
4	Electrical connections	22
<hr/>		
4.1	Safety instructions.....	22
4.2	Grounding	22
4.3	Virtual reference for IFC 300 (W and F version)	23

1.1 Solution with high-tech ceramics

The **POWERFLUX 5000** is an electromagnetic flow sensor specifically constructed for radiation areas.

All the used materials for construction of the flow sensor are selected and tested to meet the demands for the use in nuclear environments.

With its high tech ceramic tube it provides an exceptional accuracy, long term stability and a broad chemical resistance.



- ① Sandwich design
- ② Ceramic liner
- ③ Cermet electrodes

Highlights

- Excellent long-term stability and accuracy
- High-tech ceramics liner
- Fused in-place Cermet electrodes
- For highly aggressive and abrasive fluids
- Fully vacuum-resistant
- Constructed & tested for nuclear environments

Industries

- Nuclear

Applications

- Cooling water
- Transport water
- Borated water
- Spent resin
- Sea water

1.2 Options



The **POWERFLUX 5000** is available from DN2,5 up to DN100 with a large range of pressure ratings. Two separate signal converters can be combined with the POWERFLUX 5000: the powerful and high end IFC 300 and the fully software free AFC 030 converter.

1.3 Measuring principle

An electrically conductive fluid flows inside an electrically insulated pipe through a magnetic field. This magnetic field is generated by a current, flowing through a pair of field coils.

Inside of the fluid, a voltage U is generated:

$$U = v * k * B * D$$

in which:

v = mean flow velocity

k = factor correcting for geometry

B = magnetic field strength

D = inner diameter of flowmeter

The signal voltage U is picked off by electrodes and is proportional to the mean flow velocity v and thus the flow rate Q . A signal converter is used to amplify the signal voltage, filter it and convert it into signals for totalizing, recording and output processing.

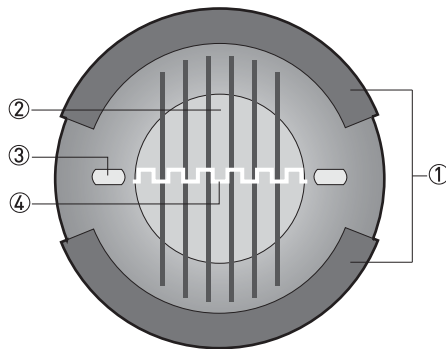

Figure 1-1: Measuring principle

- ① Field coils
- ② Magnetic field
- ③ Electrodes
- ④ Induced voltage (proportional to flow velocity)

2.1 Technical data

- *The following data is provided for general applications. If you require data that is more relevant to your specific application, please contact us or your local sales office.*
- *Additional information (certificates, special tools, software,...) and complete product documentation can be downloaded free of charge from the website (Downloadcenter).*

Measuring system

Measuring principle	Faraday's law
Application range	Electrically conductive fluids
Measured value	
Primary measured value	Flow velocity

Design

Modular construction	The measurement system consists of a flow sensor and a signal converter. It is only available as separate version.
Flow sensor	POWERFLUX 5000 sandwich version with optimized flow tube
Remote version	With AFC 030 in wall (W) mount version: POWERFLUX 5030 W In field (F) version with IFC 300 : POWERFLUX 5300 F
Nominal diameter	DN2.5...100 / 1/10...4"

Measuring accuracy

Maximum measuring error	With IFC 300
	< DN10 / 3/8" : 0.3% of the measured value + 2 mm/s DN10...100 / 3/8...4" : 0.15% of the measured value + 1 mm/s
	With AFC 030
	1% of the measured value + 2.5 mm/s
	The maximum measuring error depends on the installation conditions. For detailed information refer to refer to <i>Measurement accuracy</i> on page 11
Repeatability	±0.5% of measured value, minimum 1 mm/s
Calibration	Standard: 2 point calibration by direct volume comparison. Optional: special calibration on request.

Operating conditions

Temperature	
Process temperature	Remote version: -40...+180°C / -40...+356°F Size DN 2.5...15: -20...+180°C / -4... +356°F
Maximum temperature change (shock)	DN2.5...25: < 3 K/s DN40...100: < 0.2 K/s
Ambient temperature	-40...+65°C / -40...+149°F
Storage temperature	-50...+70°C / -58...+158°F
Measurement range	With AFC 030: 0...+12 m/s / 0...+40 ft/s With IFC 300: -12...+12 m/s / -40...+40 ft/s
Pressure	
Ambient	Atmospheric
Nominal flange pressure	
EN 1092-1	Standard:
	DN100: PN 16
	DN2.5...80: PN 40
	Option:
DN100: PN 25	
ASME B16.5	Standard:
	1/10...4": 150 lb
	Option:
1/10...4": 300 lb	
Vacuum load	0 mbar / 0 psi
Chemical properties	
Physical condition	Liquids
Electrical conductivity	Non water:
	DN25...100: $\geq 1 \mu\text{S/cm}$
	DN4...15: $\geq 5 \mu\text{S/cm}$
	DN2.5: $\geq 10 \mu\text{S/cm}$
Water : DN2.5...100: $\geq 20 \mu\text{S/cm}$	
Permissible gas content (volume)	$\leq 5\%$

Installation conditions

Installation	Take care that flow sensor always fully filled.
	For detailed information refer to <i>Installation</i> on page 15.
Flow direction	With AFC 030: Forward. With IFC 300: Forward and reverse.
	Arrow on flow sensor indicates positive flow direction.
Inlet run	≥ 5 DN (without disturbing flow, after a single 90° bend)
	≥ 10 DN (after a double bend = 2 x 90°)
Outlet run	≥ 2 DN
Dimensions and weights	For detailed information refer to <i>Installation conditions</i> on page 16.

Materials

Sensor housing	DN2.5...15: stainless steel 1.4408
	DN25...100: stainless steel 1.4301
Measuring tube	Ceramic
Connection box	Standard:
	Stainless steel (316)
Grounding rings	Standard:
	Stainless steel
	Other materials on request.
Mounting materials	Standard: stainless steel centering bushing
	Option: stud bolts and nuts in stainless steel or galvanized steel
Gaskets	Graphite (Rivatherm)
	Details and other materials: contact our product support.
Measuring electrodes	DN2.5...25: Cermet
	DN40...100: Platinum

Process connections

EN 1092-1	Standard:
	DN100: PN 16
	DN2.5...80: PN 40
	Option:
	DN100: PN 25
ASME	Standard:
	1/10...4": 150 lb
	Option:
	1/10...4": 300 lb
JIS	DN2.5...100: 10...20 K

Electrical connections

Signal cable	
Note: cable type and maximal length of the cable to be advised, after evaluation of the application concerned.	
Type A (DS and DS-L)	In combination with the IFC 300 and AFC 030 signal converter
	Standard cable, double shielded.
	For detailed information refer to the documentation of the relevant signal converter.
Type B (BTS)	In combination with the IFC 300 signal converter
	Optional cable, triple shielded.
	For detailed information refer to the documentation of the relevant signal converter.
I/O	For full details of I/O options, including data streams and protocols, see the technical data sheet of the relevant signal converter.
Others	For detailed information of the connection cables of the AFC 030 see the manual of the signal converter.
Optionally cable	
Signal cable	Multi conductor cable, spiral corrugated, double shielded with copper flame retardant outer shield (acc. IEC 60332-3-23 Cat. B) type L45551.
Min. bending radius allowed	For all cables, minimal bending radius $r = 10 \times \emptyset$ (outer diameter cable).

Approvals and certifications

CE	
This device fulfills the statutory requirements of the EU directives. The manufacturer certifies successful testing of the product by applying the CE mark.	
	For full information of the EU directive & standards and the approved certifications; see the CE declaration or the manufacturer website.
Nuclear approvals	
EMC	IEC 61000-4
Radiation	TID 1E+08 Rad
Vibration	EN 60068-2-6
Seismic	IEC 60980 - 1989 (300 m/s ²)
Other approvals and standards	
Shock test	IEC 68-2-27
	30 g for 18 ms
Vibration test	IEC 68-2-64
	f = 20 - 2000 Hz, rms = 4.5 g, t = 30 min.

2.2 Measurement accuracy

Every electromagnetic flowmeter is calibrated by direct volume comparison. The wet calibration validates the performance of the flowmeter under reference conditions against accuracy limits.

The accuracy limits of electromagnetic flowmeters are typically the result of the combined effect of linearity, zero point stability and calibration uncertainty.

Reference conditions

- Medium: water
- Temperature: +5...35°C / +41...95°F
- Operating pressure: 0.1...5 barg / 1.5...72.5 psig
- Inlet section: ≥ 5 DN
- Outlet section: ≥ 2 DN

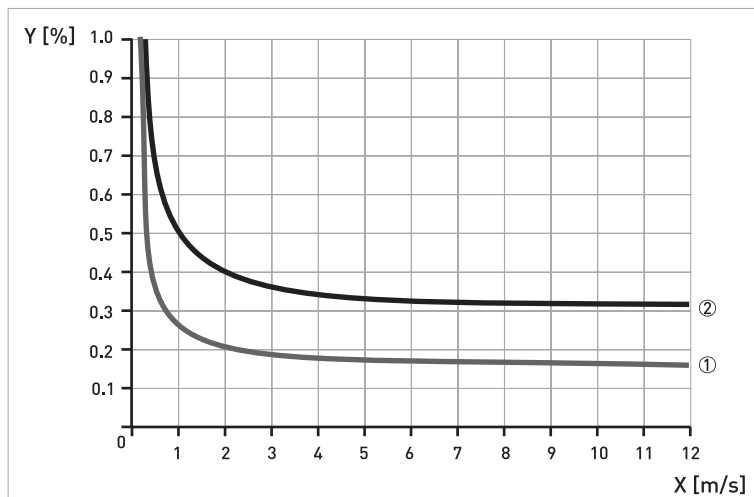

Figure 2-1: X [m/s] : flow velocity
Y [%]: deviation from the actual measured value (mv)

Accuracy with signal converter IFC 300

Flow sensor diameter	Accuracy	Curve
DN10...100 / 3/8...4"	0.15% + 1 mm/s	①
< DN10 / 3/8..."	0.3% + 2 mm/s	②

AFC 030 accuracy

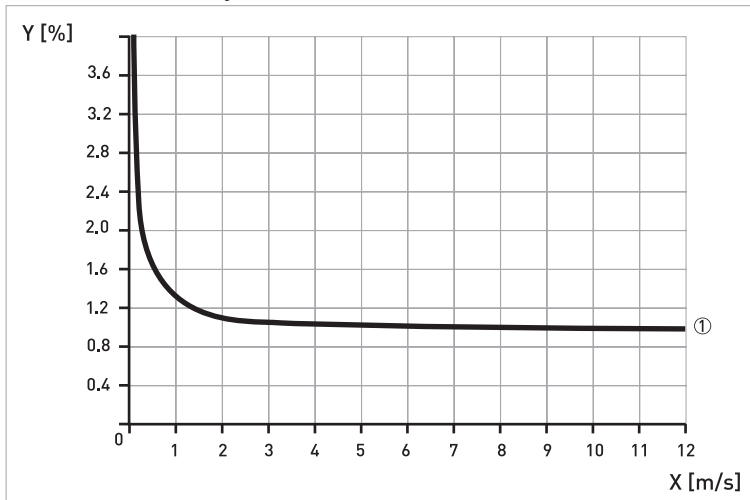

Figure 2-2: X [m/s] : flow velocity
 Y [%]: deviation from the actual measured value (mv)

① Minimal accuracy 1% of measured value + 2.5 mm/s

2.3 Dimensions and weights

Sensor: remote version DN2.5...15		a = 88 mm / 3.5" b = 139 mm / 5.5" ① c = 106 mm / 4.2" Total height = H + a
Sensor: remote version DN25...100		a = 88 mm / 3.5" b = 139 mm / 5.5" ① c = 106 mm / 4.2" Total height = H + a

① The value may vary depending on the used cable glands.

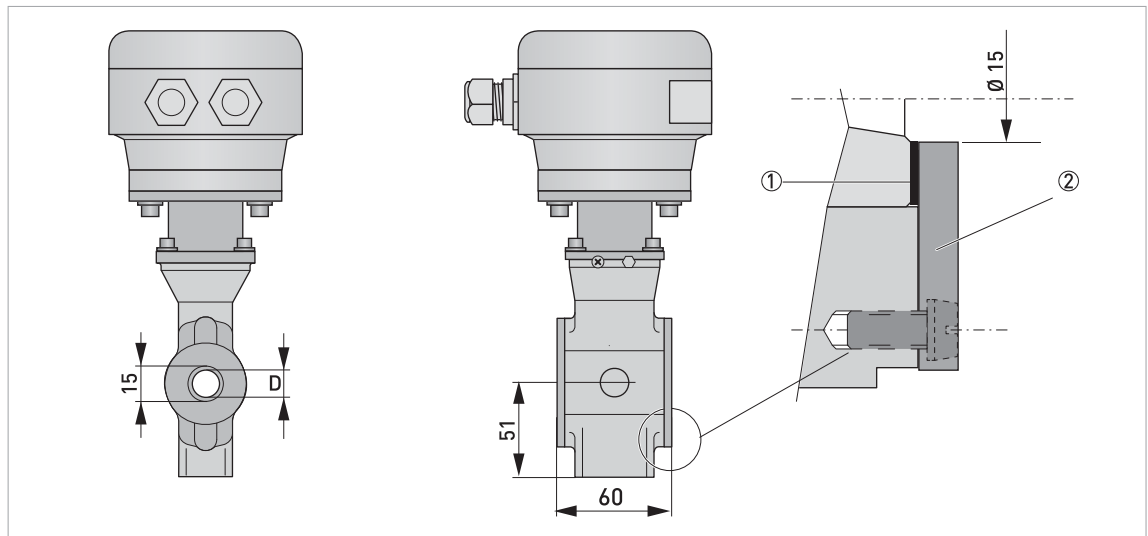

Figure 2-3: Construction details DN2.5...15

- ① Gasket
- ② Grounding ring

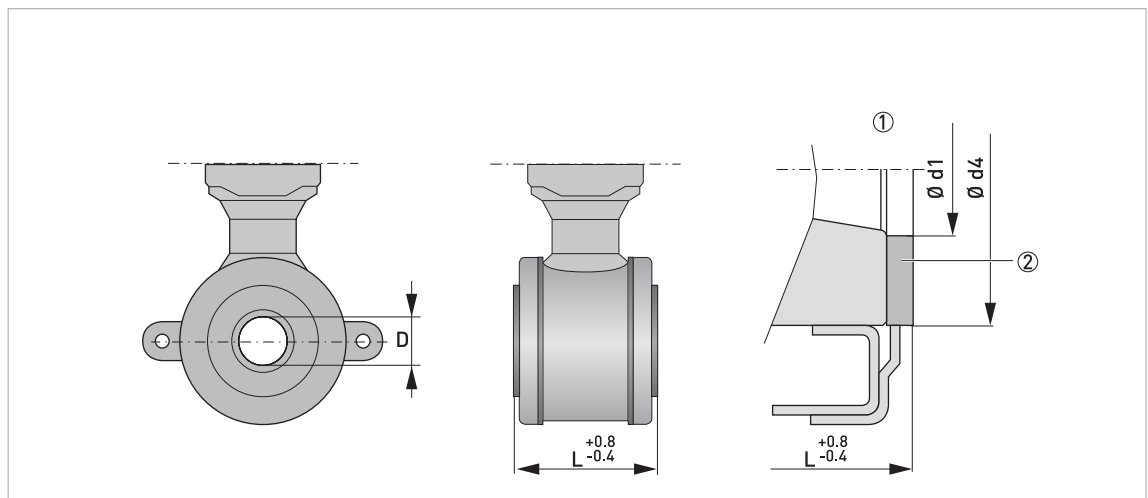

Figure 2-4: Construction details DN25...100

- ① Situation without grounding rings
- ② Gasket

- All data given in the following tables are based on standard versions of the flow sensor only.
- Note that for other pressure ratings than mentioned, the dimensions may be different.

Nominal size	Dimensions [mm]						Approx. weight [kg]	
	DN	L	H	W	D	Ød1		Ød4
2.5	60 ①	123	44			-	-	1.6
4	60 ①	123	44			-	-	1.6
6	60 ①	123	44			-	-	1.6
10	60 ①	123	44			-	-	1.6
15	60 ①	123	44			-	-	1.6
25	58 ②	116	68	20	26	46		1.6
40	83 ②	131	83	30	39	62		2.4
50	103 ②	149	101	40	51	74		2.9
80	153 ②	181	133	60	80	106		6.4
100	203 ②	206	158	80	101	133		8.8

① Total fitting length of flowmeter with integrated rings: dimension L + 2 x gasket thickness.

② Total fitting length of flowmeter without rings: dimension L only.

Nominal size	Dimensions [inches]						Approx. weight [lb]	
	ASME	L	H	W	D	Ød1		Ød4
1/10"	2.36 ①	4.84	1.73			-	-	3.53
1/8"	2.36 ①	4.84	1.73			-	-	3.53
¼"	2.36 ①	4.84	1.73			-	-	3.53
3/8"	2.36 ①	4.84	1.73			-	-	3.53
½"	2.36 ①	4.84	1.73			-	-	3.53
1"	2.28 ②	4.57	2.68	0.79	1.02	1.81		3.53
1½"	3.27 ②	5.16	3.27	1.18	1.54	2.44		5.29
2"	4.06 ②	5.87	3.98	1.57	2.01	2.91		6.39
3"	6.02 ②	7.13	5.24	2.36	3.15	4.17		14.11
4"	7.99 ②	8.11	6.22	3.15	3.98	5.24		19.40

① Total fitting length of flowmeter with integrated rings: dimension L + 2 x gasket thickness.

② Total fitting length of flowmeter without rings: dimension L only.

3.1 Intended use

Responsibility for the use of the measuring devices with regard to suitability, intended use and corrosion resistance of the used materials against the measured fluid lies solely with the operator.

The manufacturer is not liable for any damage resulting from improper use or use for other than the intended purpose.

The **POWERFLUX 5000** flowmeter measures the volumetric flow rate of electrically conductive liquids

3.2 General notes on installation

Inspect the packaging carefully for damages or signs of rough handling. Report damage to the carrier and to the local office of the manufacturer.

Do a check of the packing list to make sure that you have all the elements given in the order.

Look at the device nameplate to ensure that the device is delivered according to your order. Check for the correct supply voltage printed on the nameplate.

3.2.1 Vibration

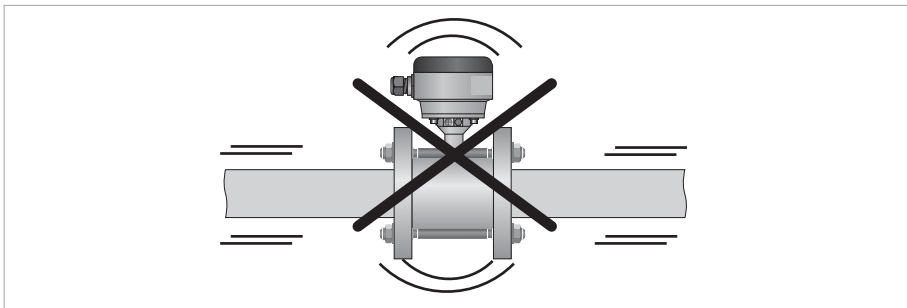

Figure 3-1: Avoid vibrations

3.2.2 Magnetic field

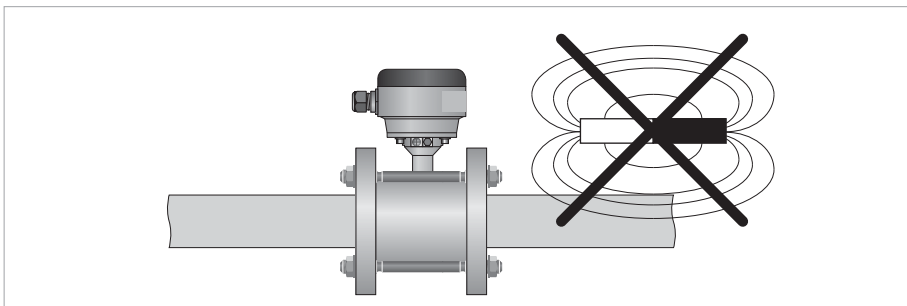

Figure 3-2: Avoid magnetic fields

3.3 Installation conditions

3.3.1 Inlet and outlet

Use straight inlet and outlet pipe sections to prevent flow distortion or swirl, caused by bends and T- sections.

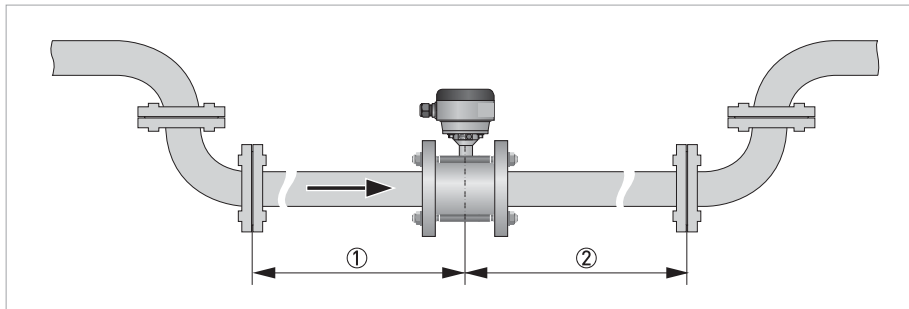

Figure 3-3: Recommended inlet and outlet section

- ① Refer to chapter "Bends in 2 or 3 dimensions"
- ② ≥ 2 DN

3.3.2 Bends in 2 or 3 dimensions

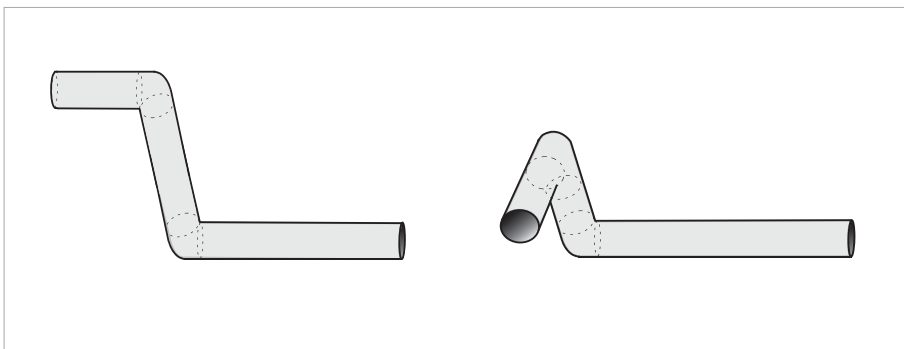

Figure 3-4: Inlet when using 2 and/or 3 dimensional bends upstream of the flowmeter

Inlet length: using bends in 2 dimensions: ≥ 5 DN; when having bends in 3 dimensions: ≥ 10 DN

*2 Dimensional bends in a vertical plane only, while 3 Dimensional bends both occur in a vertical **and** horizontal plane.*

3.3.3 T-section

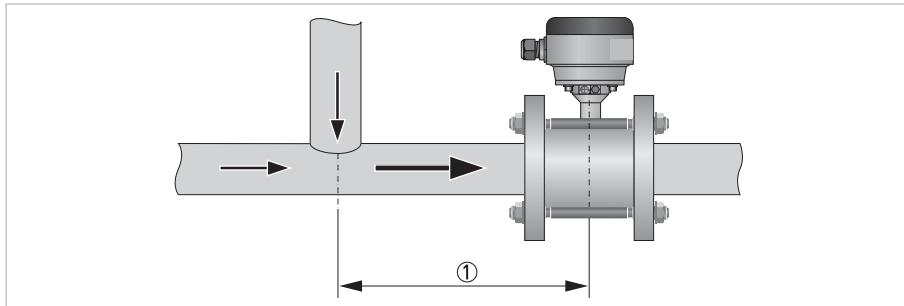
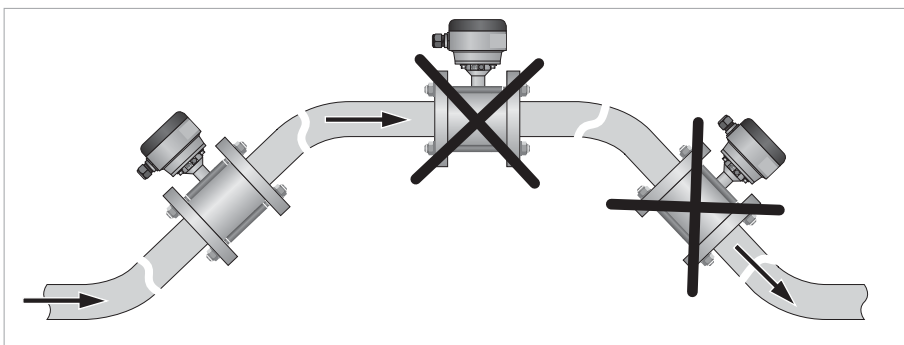
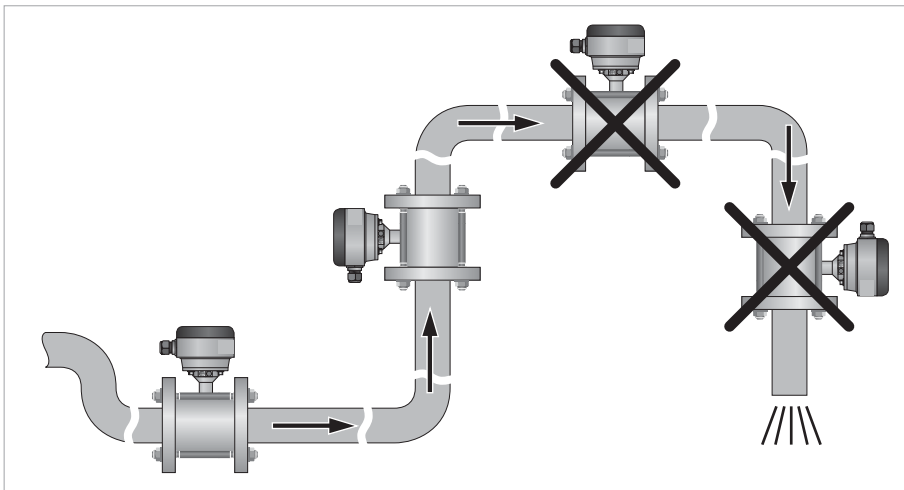

Figure 3-5: Distance behind a T-section

① ≥ 10 DN

3.3.4 Bends



Avoid draining or partial filling of the flow sensor

3.4 Open feed or discharge

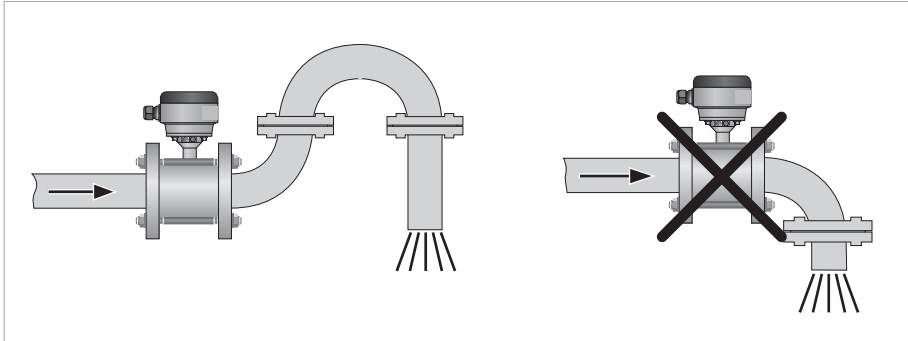

Figure 3-6: Installation in front of an open discharge

3.5 Flange deviation

Max. permissible deviation of pipe flange faces:
 $L_{max} - L_{min} \leq 0.5 \text{ mm} / 0.02''$

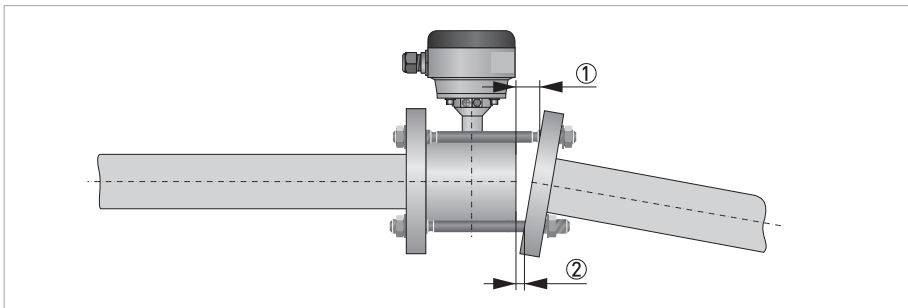

Figure 3-7: Flange deviation

- ① L_{max}
- ② L_{min}

3.6 Pump

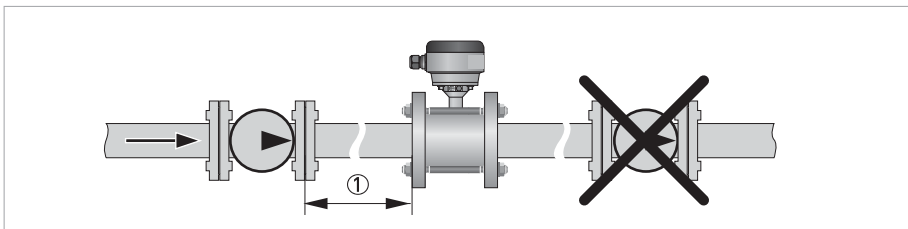

Figure 3-8: Installation behind a pump

- ① Inlet: $\geq 3 \text{ DN}$

3.7 Control valve

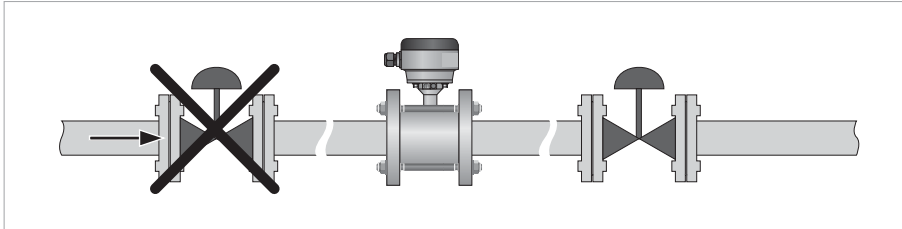

Figure 3-9: Installation in front of a control valve

3.8 Air venting and vacuum forces

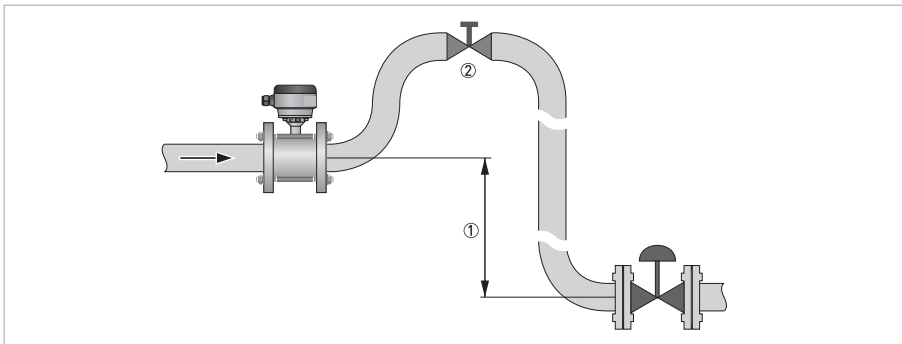

Figure 3-10: Air venting

- ① ≥ 5 m
- ② Air ventilation point

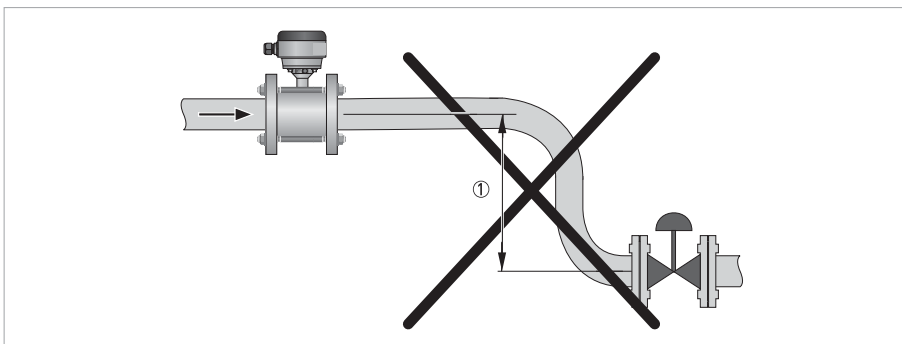

Figure 3-11: Vacuum

- ① ≥ 5 m

3.9 Mounting position

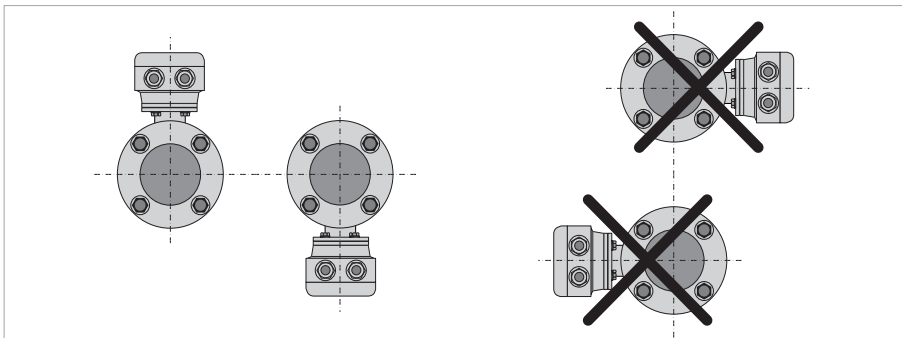

Figure 3-12: Mounting position

- Mount flow sensor either with signal converter aligned upwards or downwards.
- Install flow sensor in line with the pipe axis.
- Pipe flange faces must be parallel to each other.

3.10 Mounting

3.10.1 Torques and pressure

- *Please use stainless steel A2 / 6.9 class bolts.*
- *Make sure the connecting flanges are of type raised face (RF).*

EN 1092-1

Nominal size DN [mm]	Pressure rating	Max. allowable operating pressure [bar]
2.5...80	PN 40	40
100	PN 16	16
100	PN 25	25

ASME B 16.5

Nominal size [inch]	Pressure rating	Max. allowable operating pressure [psig]
1/10...4"	150 lb	230
1/10...3"	300 lb	580

- *Pressures at 20°C / 68°F.*
- *For higher temperatures, the pressure and temperature ratings are as per ASME B16.5.*

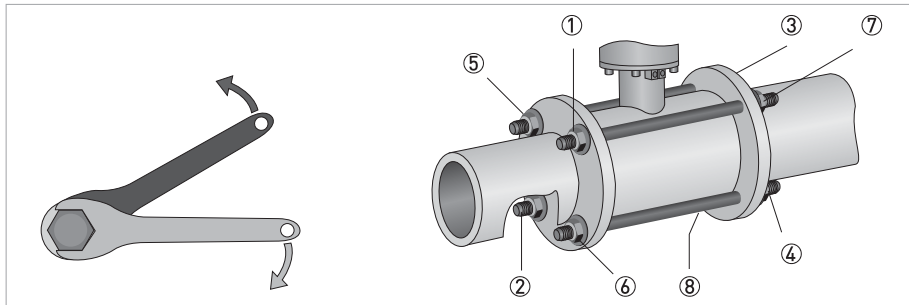

Figure 3-13: Tighten the bolts in fixed order, see picture.

Max. torque:

- Step 1: approx. 50% of max. torque
- Step 2: approx. 80% of max. torque
- Step 3: 100% of max. torque given in tables

EN 1092-1

Nominal size DN [mm]	Counter flanges & bolts		Max. allowable torque	
	Rating	Size	Nm	ftlb
2.5...10	PN 40	M12 x 141	32	24
15	PN 40	M12 x 141	32	24
25	PN 40	M12 x 141	32	24
40	PN 40	M16 x 176	66	49
50	PN 40	M16 x 203	82	60
80	PN 40	M16 x 261	69	51
100	PN 16	M16 x 303	106	78
100	PN 25	M20 x 176	133	98

ASME B 16.5

Nominal size DN [mm]	Counter flanges & bolts		Max. allowable torque	
	Rating	Size	Nm	ftlb
1/10...3/8"	150 lb	1/2"UNC x 142	33	33
1/2"	150 lb	1/2"UNC x 142	33	33
1"	150 lb	1/2"UNC x 142	33	24
1 1/2"	150 lb	1/2"UNC x 174	54	40
2"	150 lb	5/8"UNC x 215	83	61
3"	150 lb	5/8"UNC x 268	138	102
4"	150 lb	5/8"UNC x 318	108	80

The specified torque values are dependent on variables (temperature, bolt material, gasket material, lubricants, etc.) which are not within the control of the manufacturer. Therefore the values should be regarded as indicative only.

4.1 Safety instructions

All work on the electrical connections may only be carried out with the power disconnected. Take note of the voltage data on the nameplate!

Observe the national regulations for electrical installations!

For devices used in hazardous areas, additional safety notes apply; please refer to the Ex documentation.

Observe without fail the local occupational health and safety regulations. Any work done on the electrical components of the measuring device may only be carried out by properly trained specialists.

Look at the device nameplate to ensure that the device is delivered according to your order. Check for the correct supply voltage printed on the nameplate.

4.2 Grounding

The device must be grounded in accordance with regulations in order to protect personnel against electric shocks.

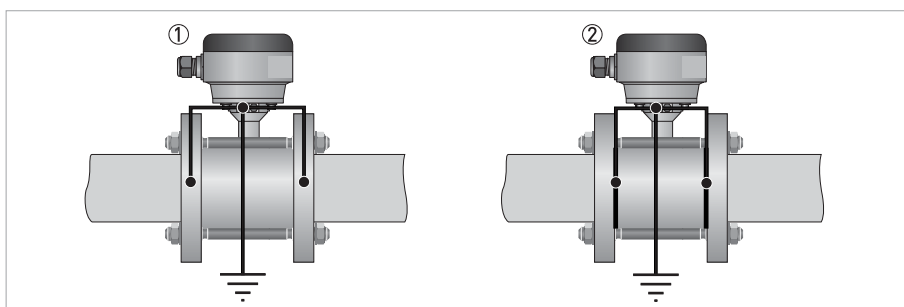

Figure 4-1: Grounding

- ① Metal pipelines, not internally coated. Grounding without grounding rings!
- ② Metal pipelines with internal coating and non-conductive pipelines. Grounding with grounding rings!

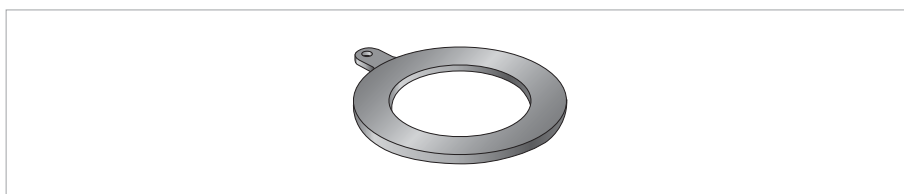

Figure 4-2: Grounding ring number 1

Grounding ring number 1 (optional for DN25...150): Thickness: 3 mm / 0.1" (tantalum: 0.5 mm / 0.02")

For diameter DN10 and DN15, grounding rings are integrated as standard in the flow sensor construction.

4.3 Virtual reference for IFC 300 (W and F version)

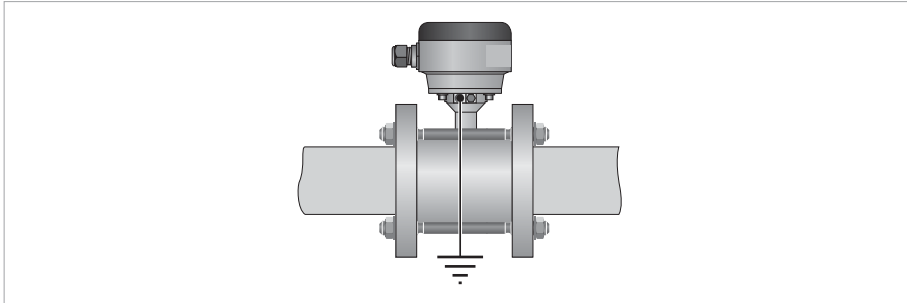
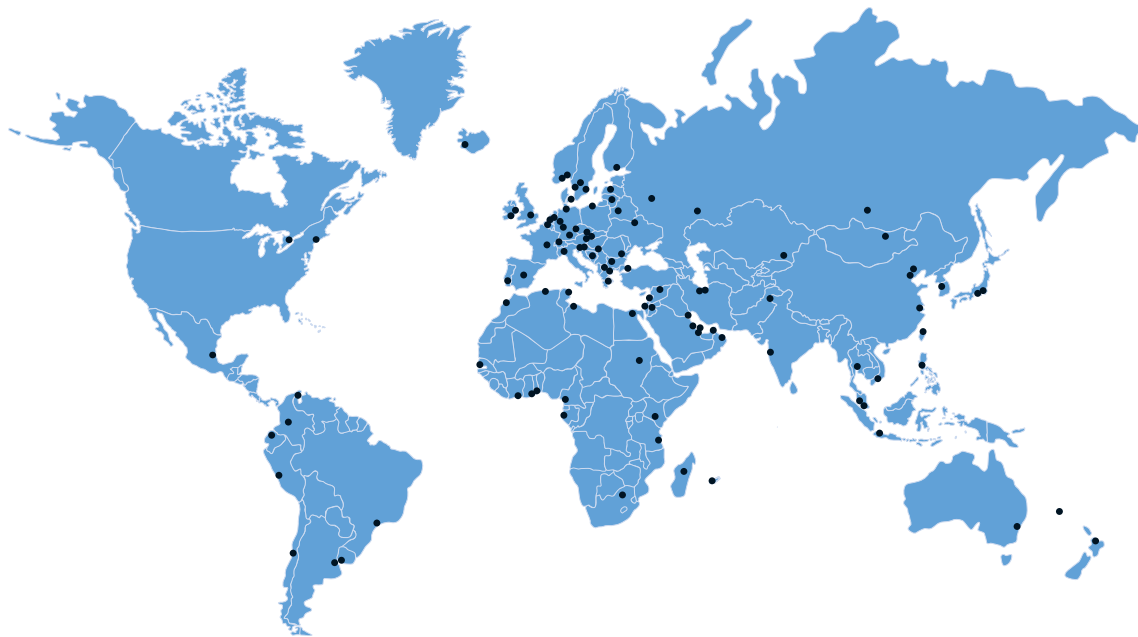

Figure 4-3: Virtual reference

Minimum requirements:

- Size: \geq DN10
- Electrical conductivity: \geq 200 μ S/cm
- Signal cable: max. 50 m / 164 ft, type DS



KROHNE – Process instrumentation and measurement solutions

- Flow
- Level
- Temperature
- Pressure
- Process Analysis
- Services

Head Office KROHNE Messtechnik GmbH
Ludwig-Krohne-Str. 5
47058 Duisburg (Germany)
Tel.: +49 203 301 0
Fax: +49 203 301 10389
info@krohne.com

The current list of all KROHNE contacts and addresses can be found at:
www.krohne.com

KROHNE