



OPTISENS PH 9500 **Technical Datasheet**

pH sensor for water industry

- High quality and precise glass sensor for usage in low conductivity media
- Refillable sensor with adjustable flow rate
- Low maintenance costs and a long life cycle

The documentation is only complete when used in combination with the relevant documentation for the signal converter.

1 Product features	3
1.1 pH sensor for water applications	3
1.2 Design and options	5
1.3 pH measurement	7
2 Technical data	9
2.1 Technical data	9
2.2 Dimensions	10
3 Installation	11
3.1 General notes on installation	11
3.2 Intended use	11
3.3 Pre-installation requirements	11
3.4 Installing the sensor	12
3.4.1 General installation instructions	12
4 Electrical connections	13
4.1 Safety instructions	13
4.2 Connecting the cable to the sensor	13
4.3 Connecting the sensor cable to the MAC 100	14
4.4 Connecting the external temperature sensor	15
5 Order information	16
5.1 Order code	16
5.2 Accessories	17
6 Notes	18

1.1 pH sensor for water applications

The OPTISENS PH 9500 sensor is characterised by standardised design, easy handling and a long life cycle. In combination with the MAC 100 signal converter it is possible to create an extremely reliable and low-cost measurement systems, which is suitable for a wide range of water measurement tasks.

Designed as combined sensor with built-in reference electrode the OPTISENS PH 9500 is equipped with 3 ceramic diaphragms. The sensor can be easily adapted to various application requirements and it is extremely service friendly and durable.



- ① Cable connector DIN coax
- ② Glass
- ③ Diaphragm
- ④ Membrane glass

Highlights

- Suitable for media with low conductivity water
- 3 ceramic diaphragms for faster response time and more accurate readings
- Special reference systems for extended lifetime and a wide application range
- Suitable for connection to the MAC 100 signal converter
- Accessories like PG 13.5 mounting kit and KCl reservoir available

Industries

- Water industry
- Power plants

Applications

- Cooling water
- Boiler feed water
- Process water

1.2 Design and options



The OPTISENS PH 9500 sensor is manufactured using highly sensitive special glass which can be used in various applications due to its wide temperature range.

Accessories like PG 13.5 mounting kit and KCl reservoir are also available.

MAC 100 signal converter for various analytical parameter



A complete measuring system consists of:

- MAC 100 signal converter
- 1 or 2 sensors
- Mounting assemblies

Up to 2 sensors (for identical or different parameters) can be connected to the signal converter.

The MAC 100 signal converter can be adapted perfectly for your requirements. Select between 1 or 2 signal inputs, 3 x outputs, relays, various operation language, power supply and further additional features. The standardised user interface also speeds up commissioning of the device.

Made to Fit

Mounting assemblies SENSOFIT series

As a complete provider for water analysis, we naturally offer a complete range of assemblies, like retractable, immersion and flow-through assemblies in a wide range of materials. Special versions for special operating conditions are available on request.

For the OPTISENS PH 9500 sensor type the following individual assemblies are available:

- SENSOFIT FLOW 1000 series - Flow-through assemblies (with PG 13.5 mounting kit)
- SENSOFIT IMM 2000 series - Immersion assemblies (with PG 13.5 mounting kit)

For further information please consider the technical datasheets.

1.3 pH measurement

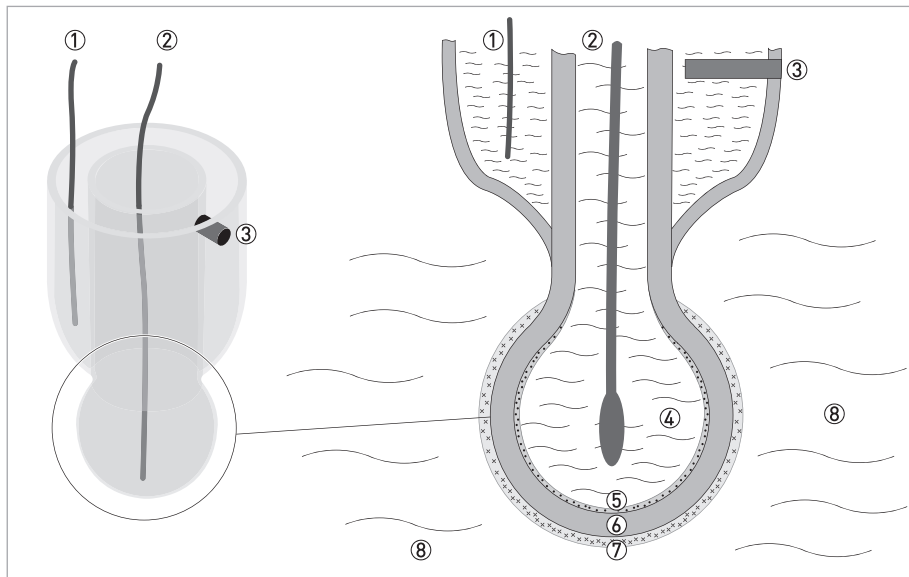

Figure 1-1: Measuring principle for pH measurement

- ① Reference electrode
- ② Measuring electrode
- ③ Diaphragm in contact with KCl solution and measuring medium
- ④ Inner pH 7 buffer solution
- ⑤ Surface potential on the inside [contact with buffer solution]
- ⑥ pH sensitive glass (membrane glass)
- ⑦ Surface potential on the outside [contact with measuring medium]
- ⑧ Measuring medium

The measuring principle of a pH sensor is based on a membrane glass (pH sensitive glass). When the membrane glass gets into contact with a liquid, a thin layer of hydrated gel develops on the surface, enabling an ion exchange between the glass surface and the liquid. The so-called Nernst potential builds up on the glass surface. If both sides of the glass are in contact with liquids, a voltage may be detected between the two surface potentials. The voltage correlates to the difference in H^+ ion concentration and thus to the difference of pH values in both liquids.

The pH sensor contains an internal buffer solution with a known pH value. If the pH value of the measuring medium on the outside of the sensor is equal to the pH value of the inner buffer, the resulting voltage is 0 V.

If the pH value of the medium differs from the internal pH value, a voltage between the internal and the external layer can be measured. From the resulting voltage, the pH difference of the two liquids can be calculated.

The voltage is measured using a measuring electrode and a reference electrode; both are built into the sensor. The measuring electrode is in contact with the known buffer solution in the pH sensitive glass bulb. The reference electrode is immersed into a saturated solution of potassium chloride (KCl). The KCl solution itself is in electrical contact with the measuring medium by means of a diaphragm. The diaphragm prevents the measuring medium from penetrating into the reference system but still allows electrical contact with the measuring medium.

The voltage change of a pH sensor at 25°C / 77°F is around 59 mV for each pH unit. This is also called the slope of the pH sensor. The slope is temperature dependent and decreases over life time of the sensor.

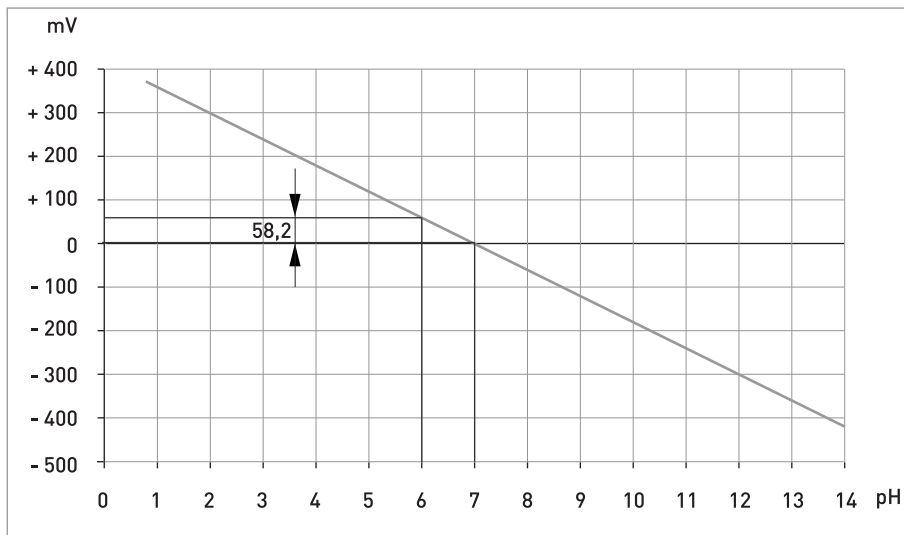

Figure 1-2: Optimal slope at 25°C / 77°F

To compensate for the temperature dependency of the pH measurement, the temperature of the medium can be measured and automatically compensated in the signal converter.

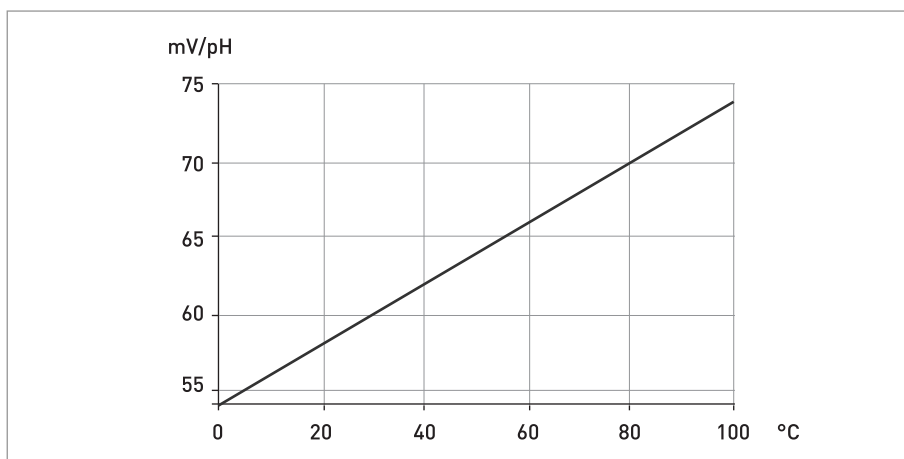

Figure 1-3: Temperature dependency of the slope

2.1 Technical data

- *The following data is provided for general applications. If you require data that is more relevant to your specific application, please contact us or your local sales office.*
- *Additional information (certificates, special tools, software,...) and complete product documentation can be downloaded free of charge from the website (Downloadcenter).*

Design

Measuring principle	Potentiometric
Measuring range	0...14 pH
Shaft diameter	Ø12 mm / 0.5"
Insertion length	160 mm / 6.3" (w/o PG 13.5); 120 mm / 4.72" (w/ PG 13.5)
Connector	S7 DIN Coax

Measuring accuracy

Accuracy	0.2% full scale
Reproducibility	0.2% full scale

Operating conditions

Temperature range	-5...+100°C / +23...+212°F
Pressure range	Pressureless
Conductivity	Min. 50 µS/cm

Installation conditions

Weight approx.	Approx. 60 g / 0.13 lb
Process connection	PG 13.5 (Mounting kit PG 13.5 optional)

Materials

Sensor shaft	Glass
Membrane glass	AH glass
Inner buffer	pH 7.0
Reference	Ag/Ag/3M KCl
Diaphragm	Ceramic

2.2 Dimensions

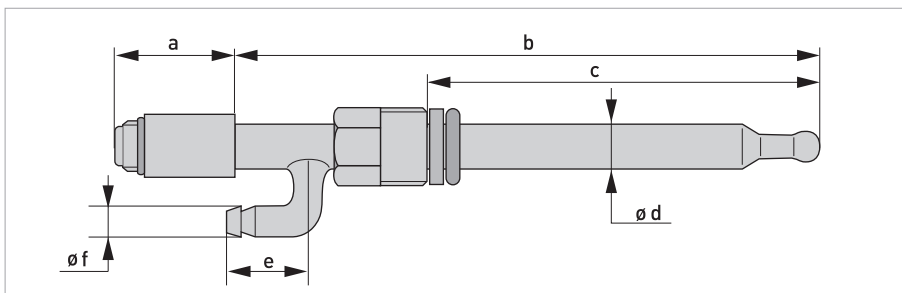

Figure 2-1: Dimension of the pH sensor

	Dimensions [mm]	Dimensions [inch]
a	31	1.2
b	160	6.3
c	120	4.7
d	$\varnothing 12$	$\varnothing 0.5$
e	22	0.8
f	$\varnothing 8$	$\varnothing 0.3$

3.1 General notes on installation

Inspect the packaging carefully for damages or signs of rough handling. Report damage to the carrier and to the local office of the manufacturer.

Do a check of the packing list to make sure that you have all the elements given in the order.

Look at the device nameplate to ensure that the device is delivered according to your order.

3.2 Intended use

Responsibility for the use of the measuring devices with regard to suitability, intended use and corrosion resistance of the used materials against the measured fluid lies solely with the operator.

The manufacturer is not liable for any damage resulting from improper use or use for other than the intended purpose.

The intended use of OPTISENS PH 9500 sensor is the measurement of pH in water liquids. The sensor is suitable for connection to the MAC 100 signal converter.

3.3 Pre-installation requirements

- *Never touch or scratch the pH membrane glass of the sensor.*
- *Store the sensor in its original packaging in a dry, dust-free location. Keep it away from dirt. If necessary, clean it as described in the manual of the sensor.*

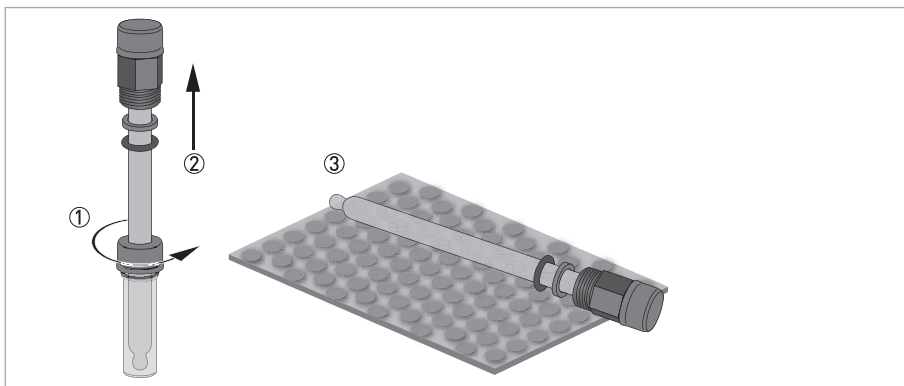

Figure 3-1: Handling the sensor

Unpacking the sensor

- Loosen the storage cap which is screwed or/and pushed on to the plastic tube ①.
- Gently pull the sensor out of the plastic tube ②.
- Lay the sensor on a soft mat/tissue ③.

3.4 Installing the sensor

3.4.1 General installation instructions

The sensor tip must always have full contact with the measuring medium.

The mounting position of the sensor should not deviate more than 75° from vertical position (sensor tip pointing downwards). Doing otherwise might cause internal air bubbles to float into the sensor glass tip. This would interrupt the electrical contact between the inner buffer solution and the glass surface.

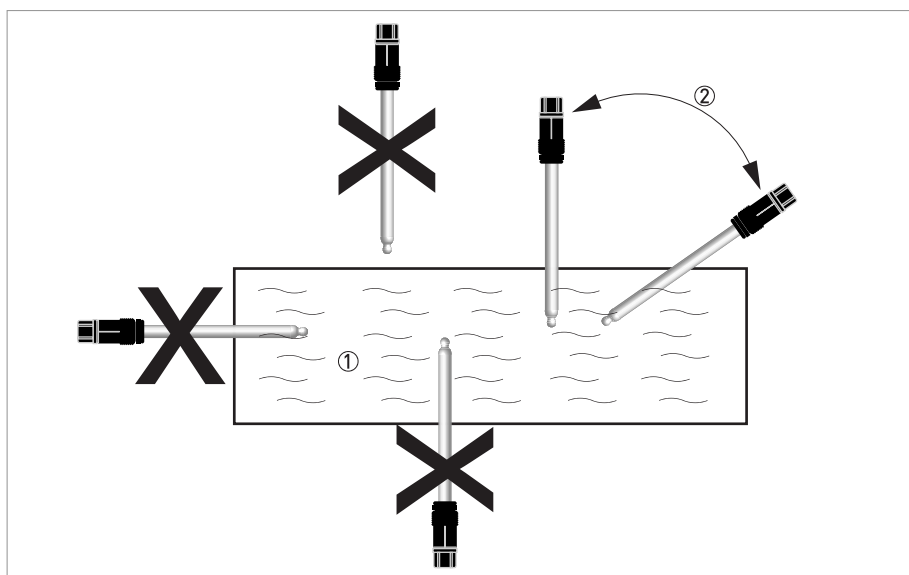

Figure 3-2: Installation requirements

- ① Measuring medium
- ② Maximum deviation of 75° from vertical position

4.1 Safety instructions

All work on the electrical connections may only be carried out with the power disconnected. Take note of the voltage data on the nameplate!

Observe the national regulations for electrical installations!

Observe without fail the local occupational health and safety regulations. Any work done on the electrical components of the measuring device may only be carried out by properly trained specialists.

Look at the device nameplate to ensure that the device is delivered according to your order.

4.2 Connecting the cable to the sensor

Moisture on the sensor connector must be avoided! Moisture may cause a short-circuit and a malfunction of the sensor!

If moisture has entered the connector dry it with air (e.g. hair blower).

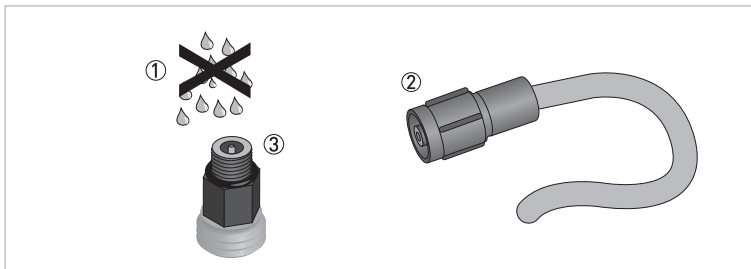

Figure 4-1: Connecting the cable to the sensor

Connecting the cable to the sensor

- Ensure that the cable and the sensor connector are absolutely dry ①.
- Screw the cable connector ② on to the sensor connector ③ and tighten it by hand.

4.3 Connecting the sensor cable to the MAC 100

All work on the electrical connections may only be carried out with the power disconnected. Take note of the voltage data on the nameplate!

Look at the device nameplate to ensure that the device is delivered according to your order.

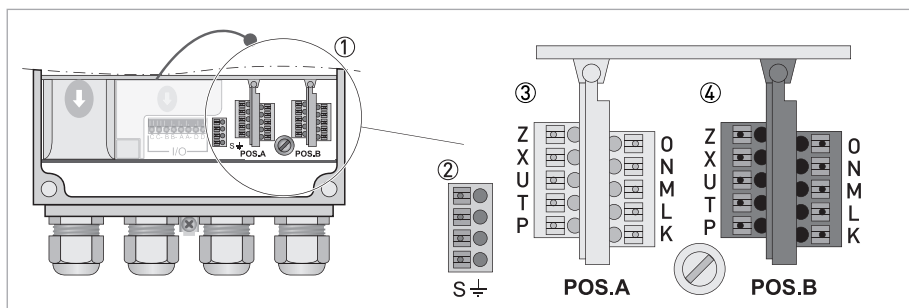

Figure 4-2: Sensor connection terminals on the MAC 100 dual channel version

- ① Sensor connection terminals
- ② Terminal block S (protective earth)
- ③ Terminal block Pos.A: terminal for sensor and temperature
- ④ Terminal block Pos.B: terminal for sensor and temperature

MAC 100 single channel version is equipped only with terminal block Pos. A.

MAC 100 dual channel version is equipped with terminal block Pos. A and Pos. B.

Wire	Terminal block Pos.A/B
Red (coax shield)	N (ref.)
Transparent (coax core)	O (pH / ORP)

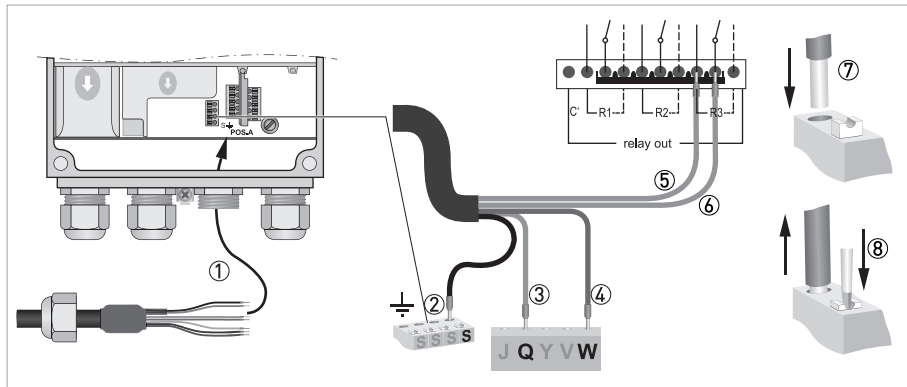

Figure 4-3: Connecting the sensor cable

The following instructions describe the connection of the sensor cables.

Connecting the sensor cable to the signal converter

- Thread the sensor cable through the outer right cable gland ①.
- Push the red wire (coax shield) ④ into terminal N ② and the transparent wire (coax core) into terminal O ③.
- To remove a wire, press down the white clip ⑤ on the corresponding terminal and pull the wire out ⑥.

4.4 Connecting the external temperature sensor

Connect an external Pt100 or Pt1000 sensor to terminal block Pos.A/B of the signal converter according to the following drawings:

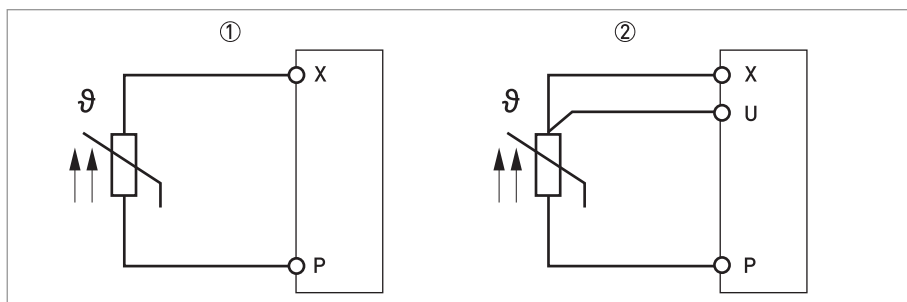

Figure 4-4: Connection of an external Pt100/1000 temperature sensor to the signal converter

- ① 2-wire connection
- ② 3-wire connection

5.1 Order code

The characters of the order code highlighted in light grey describe the standard.

VGA P	4	Sensor type
	E	OPTISENS PH 9500
		Measuring range
	1	0... 14 pH
		Diaphragm
	5	Ceramic
		Reference
	A	Ag/AgCl/3M KCl
		Body material
	1	Glass
		Glass
	1	AH glass
		Process conditions
	A	-5...+100°C / +23...+212°F, pressureless
		Process connection
	0	None
	6	PG 13.5 mounting kit
		Insertion length
	3	120 mm / 4.7"
		Sensor features
	B	1 x side arm for KCl refill, 3 x ceramic diaphragm
		Sensor option
	0	Standard
	A	incl. KCl resevoir 50 ml
		Connector type
	1	DIN Coax
		Documentation
	0	None
	1	English
	2	German
	3	French
	4	Spanish
VGA P	4	

5.2 Accessories

Consumables	Order code
250 ml buffer solutions pH4	XGA S 010020
250 ml buffer solutions pH7	XGA S 010030

Accessories	Order code
SENSOFIT FLOW 1000 Flow-through assembly	Please see technical datasheet SENSOFIT FLOW 1000
SENSOFIT IMM 1000 Immersion assembly	Please see technical datasheet SENSOFIT IMM 1000
PG 13.5 Mounting kit	XGA S 010102
KCl reservoir 50 ml	XGA S 010101
OPTISENS coax cable 5 m / 16.5 ft.	XGA W 0 11151
OPTISENS coax cable 10 m / 33 ft.	XGA W 0 11161
OPTISENS coax cable 15 m / 49 ft.	XGA W 0 11171

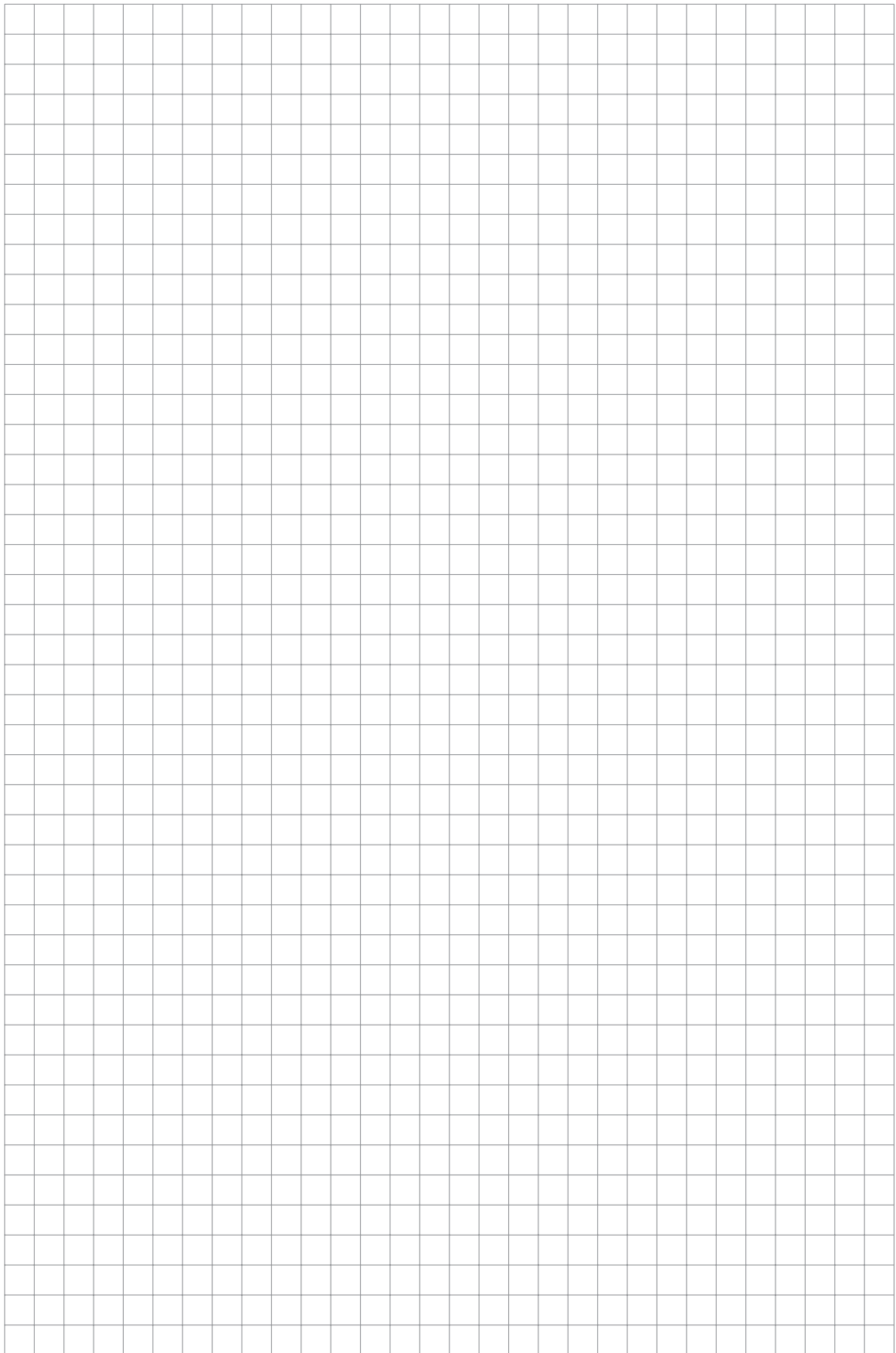



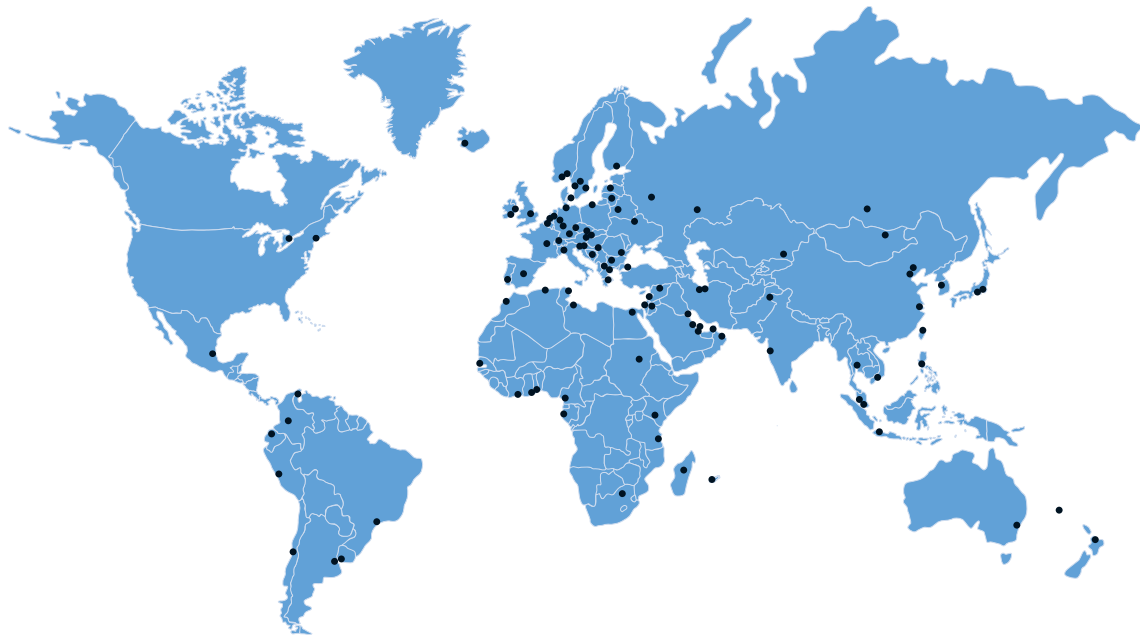

KROHNE – Process instrumentation and measurement solutions

- Flow
- Level
- Temperature
- Pressure
- Process Analysis
- Services

Head Office KROHNE Messtechnik GmbH
Ludwig-Krohne-Str. 5
47058 Duisburg (Germany)
Tel.: +49 203 301 0
Fax: +49 203 301 10389
info@krohne.com

The current list of all KROHNE contacts and addresses can be found at:
www.krohne.com

KROHNE