



OPTISENS PH 8590 **Technical Datasheet**

pH sensor for water and wastewater industry

- Large ceramic diaphragm and integrated Pt100
- Robust sensor design for all-purpose applications
- Low maintenance costs and a long life cycle

The documentation is only complete when used in combination with the relevant documentation for the signal converter.

1 Product features	3
1.1 pH sensor for water and wastewater applications	3
1.2 Design and options	5
1.3 pH measurement.....	7
2 Technical data	9
2.1 Technical data.....	9
2.2 Dimensions	10
3 Installation	11
3.1 General notes on installation	11
3.2 Intended use	11
3.3 Pre-installation requirements	11
3.4 Installing the sensor.....	12
3.4.1 General installation instructions.....	12
4 Electrical connections	13
4.1 Safety instructions.....	13
4.2 Connecting the cable to the sensor	13
4.3 Connecting the sensor cable to the MAC 100	14
4.4 Connecting the external temperature sensor	15
5 Order information	16
5.1 Order code	16
5.2 Accessories.....	18
6 Notes	19

1.1 pH sensor for water and wastewater applications

The OPTISENS PH 8590 sensor is characterised by standardised design, easy handling and a long life cycle. In combination with the MAC 100 signal converter it is possible to create an extremely reliable and low-cost measurement system, which is suitable for a wide range of water and wastewater measurement tasks.

Designed as combined sensor with built-in reference electrode the OPTISENS PH 8590 is equipped with ceramic diaphragm and integrated temperature sensor Pt100. The sensor can be easily adapted to various application requirements and it is extremely service friendly and durable.

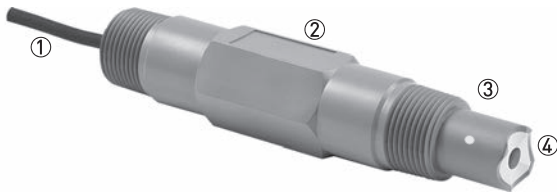

- ① Attached cable or 4-pin connector
- ② CPVC body
- ③ Diaphragm
- ④ Membrane glass

Highlights

- Large ceramic diaphragm for reliable pH measurement
- Double junction for extended lifetime and a wide application range
- Suitable for connection to the MAC 100 signal converter
- Available with 4-pin military connector or attached cable up to 10 m / 33 ft.
- With integrated Pt100 for temperature compensation
- Various mounting assemblies for an easy installation and handling

Industries

- Water
- Wastewater

Applications

- Water and wastewater monitoring
- Process water control

1.2 Design and options



The sensor type is equipped with a large ceramic diaphragm, Pt100 temperature sensor and is available with CPVC body material.

It can be easily adapted to various application requirements and can be installed directly into a pipe or tank with the 3/4" NPT (male) process connection.

The OPTISENS PH 8590 sensor is manufactured using highly sensitive membrane glass which can be used in almost all standard water and wastewater applications due to its robust sensor design.

The sensor is suitable for connection to the MAC 100 signal converter.

MAC 100 signal converter for various analytical parameter



A complete measuring system consists of:

- MAC 100 signal converter
- 1 or 2 sensors
- Mounting assemblies

Up to 2 sensors (for identical or different parameters) can be connected to the signal converter.

The MAC 100 signal converter can be adapted perfectly for your requirements. Select between 1 or 2 signal inputs, 3 x outputs, relays, various operation language, power supply and further additional features. The standardised user interface also speeds up commissioning of the device.

Made to Fit

Mounting assemblies SENSOFIT series

As a complete provider for water and wastewater analysis, we naturally offer a complete range of assemblies, like retractable, immersion and flow-through assemblies in a wide range of materials. Special versions for special operating conditions are available on request.

For the OPTISENS PH 8590 sensor type the following individual assemblies are available:

- SENSOFIT FLOW 1000 series - Flow-through assemblies
- SENSOFIT IMM 2000 series - Immersion assemblies

For further information please consider the technical datasheets.

1.3 pH measurement

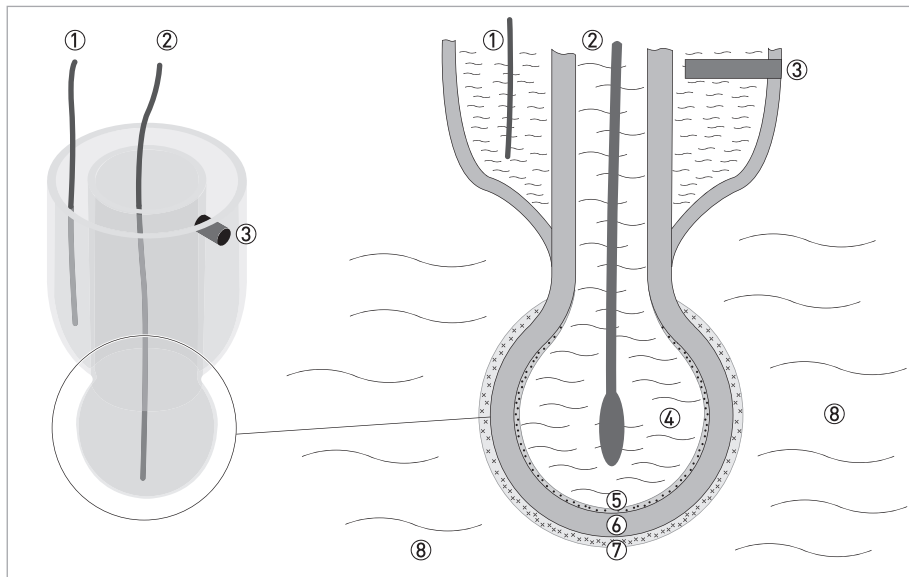

Figure 1-1: Measuring principle for pH measurement

- ① Reference electrode
- ② Measuring electrode
- ③ Diaphragm in contact with KCl solution and measuring medium
- ④ Inner pH 7 buffer solution
- ⑤ Surface potential on the inside [contact with buffer solution]
- ⑥ pH sensitive glass (membrane glass)
- ⑦ Surface potential on the outside [contact with measuring medium]
- ⑧ Measuring medium

The measuring principle of a pH sensor is based on a membrane glass (pH sensitive glass). When the membrane glass gets into contact with a liquid, a thin layer of hydrated gel develops on the surface, enabling an ion exchange between the glass surface and the liquid. The so-called Nernst potential builds up on the glass surface. If both sides of the glass are in contact with liquids, a voltage may be detected between the two surface potentials. The voltage correlates to the difference in H^+ ion concentration and thus to the difference of pH values in both liquids.

The pH sensor contains an internal buffer solution with a known pH value. If the pH value of the measuring medium on the outside of the sensor is equal to the pH value of the inner buffer, the resulting voltage is 0 V.

If the pH value of the medium differs from the internal pH value, a voltage between the internal and the external layer can be measured. From the resulting voltage, the pH difference of the two liquids can be calculated.

The voltage is measured using a measuring electrode and a reference electrode; both are built into the sensor. The measuring electrode is in contact with the known buffer solution in the pH sensitive glass bulb. The reference electrode is immersed into a saturated solution of potassium chloride (KCl). The KCl solution itself is in electrical contact with the measuring medium by means of a diaphragm. The diaphragm prevents the measuring medium from penetrating into the reference system but still allows electrical contact with the measuring medium.

The voltage change of a pH sensor at 25°C / 77°F is around 59 mV for each pH unit. This is also called the slope of the pH sensor. The slope is temperature dependent and decreases over life time of the sensor.

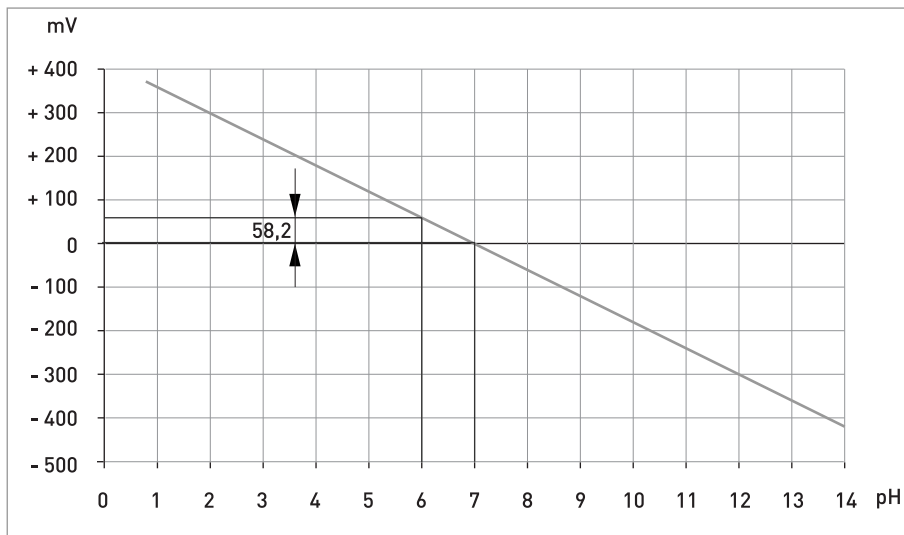

Figure 1-2: Optimal slope at 25°C / 77°F

To compensate for the temperature dependency of the pH measurement, the temperature of the medium can be measured and automatically compensated in the signal converter.

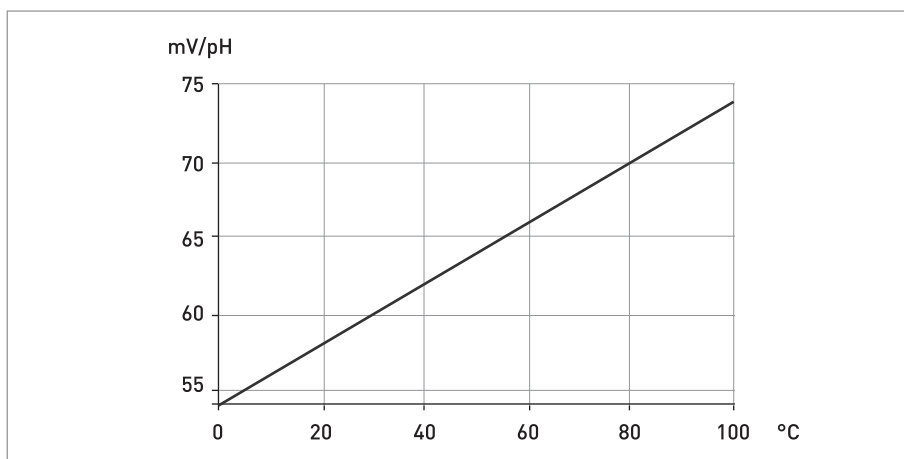

Figure 1-3: Temperature dependency of the slope

2.1 Technical data

- *The following data is provided for general applications. If you require data that is more relevant to your specific application, please contact us or your local sales office.*
- *Additional information (certificates, special tools, software,...) and complete product documentation can be downloaded free of charge from the website (Downloadcenter).*

Design

Measuring principle	Potentiometric
Measuring range	0...14 pH
Shaft diameter	20 mm / 0.79"
Insertion length	23 mm / 0.91" or 44 mm / 1.73"
Temperature sensor	Pt100
Connector	4-pin military connector or attached cable (7.26 m / 25 ft or 10 m / 33 ft)

Measuring accuracy

Accuracy	+/- 0.1 pH unit
Reproducibility	+/- 0.1 pH unit

Operating conditions

Temperature range	-5...+80°C / +23...+176°F
Pressure range	Max. 5.9 bar at 25°C / 85 psi at 77°F
Conductivity	Min. > 150 µS/cm

Installation conditions

Weight approx.	Approx. 193 g / 0.43 lb
Process connection	3/4" NPT (male)

Materials

Sensor shaft	CPVC
Membrane glass	Multi purpose glass
Inner buffer	pH 7.0
Reference	KCl gel double junction
Diaphragm	Ceramic

2.2 Dimensions

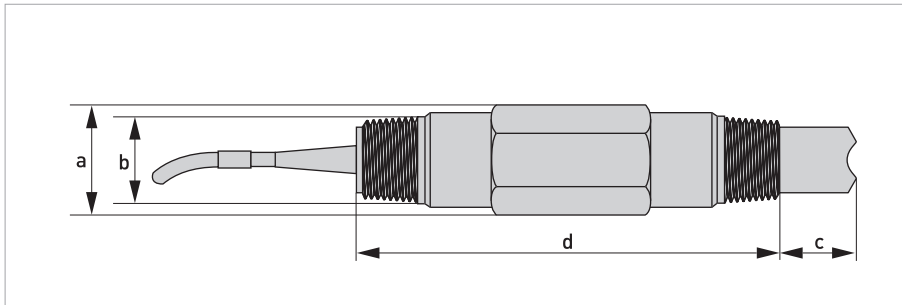

Figure 2-1: Dimensions OPTISENS PH 8590

	Dimensions [mm]	Dimensions [inch]
a	Ø 33	Ø 1.3
b	3/4 NPT (male)	
c	23 / 44	0.91 / 1.73
d	128	5.04

3.1 General notes on installation

Inspect the packaging carefully for damages or signs of rough handling. Report damage to the carrier and to the local office of the manufacturer.

Do a check of the packing list to make sure that you have all the elements given in the order.

Look at the device nameplate to ensure that the device is delivered according to your order.

3.2 Intended use

Responsibility for the use of the measuring devices with regard to suitability, intended use and corrosion resistance of the used materials against the measured fluid lies solely with the operator.

The manufacturer is not liable for any damage resulting from improper use or use for other than the intended purpose.

The intended use of OPTISENS PH 8590 sensor is the measurement of pH in water liquids. The sensor is suitable for connection to the MAC 100 signal converter.

3.3 Pre-installation requirements

- *Never touch or scratch the membrane glass of the sensor.*
- *Make sure that the glass tip is clean and dust-free. If necessary, clean the tip as described in the manual of the sensor.*

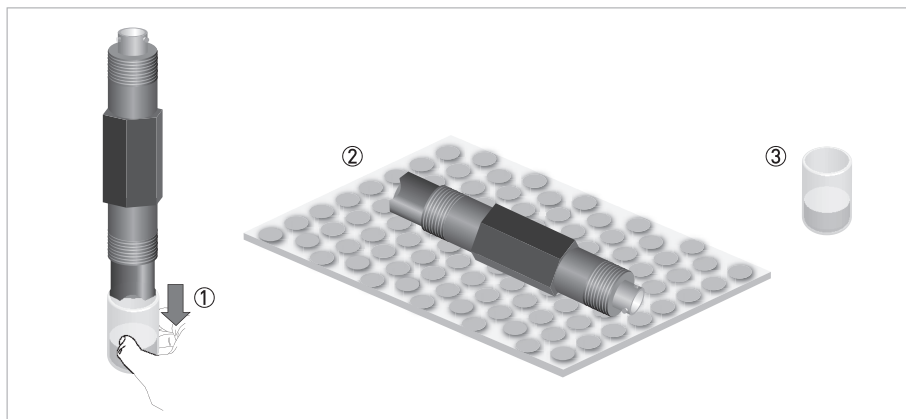

Figure 3-1: Handling the sensor

Unpacking the sensor

- Gently pull the protection cap from the sensor ①.
- Lay the sensor on a soft mat/tissue ②.
- Keep the protection cap in the original packaging ③.

3.4 Installing the sensor

3.4.1 General installation instructions

The sensor tip must always have full contact with the measuring medium.

The mounting position of the sensor should not deviate more than 75° from vertical position (sensor tip pointing downwards). Doing otherwise might cause internal air bubbles to float into the sensor glass tip. This would interrupt the electrical contact between the inner buffer solution and the glass surface.

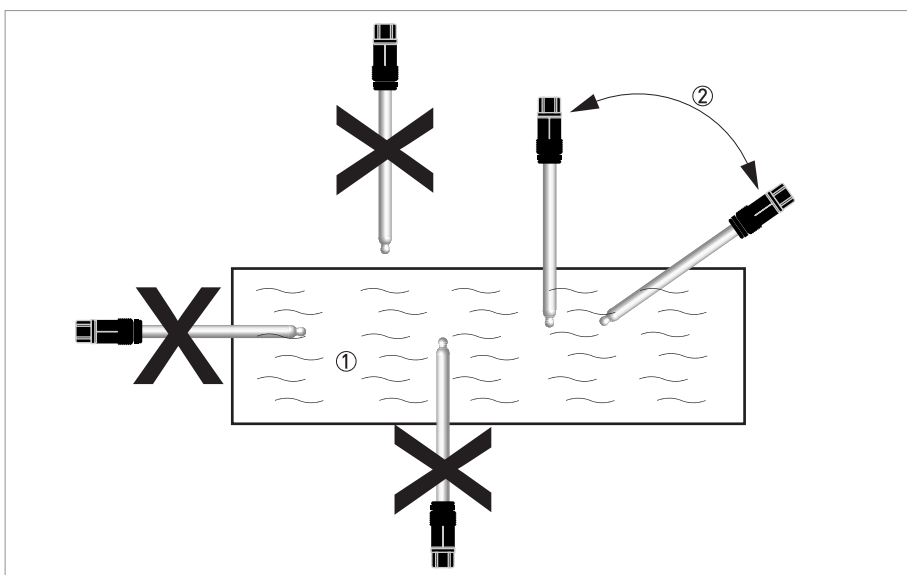

Figure 3-2: Installation requirements

- ① Measuring medium
- ② Maximum deviation of 75° from vertical position

4.1 Safety instructions

All work on the electrical connections may only be carried out with the power disconnected. Take note of the voltage data on the nameplate!

Observe the national regulations for electrical installations!

Observe without fail the local occupational health and safety regulations. Any work done on the electrical components of the measuring device may only be carried out by properly trained specialists.

Look at the device nameplate to ensure that the device is delivered according to your order.

4.2 Connecting the cable to the sensor

Moisture inside the sensor connector must be avoided! Moisture may cause a shortcut and deliver erratic readings!

If moisture has entered the connector dry it with air (e.g. hair blower).

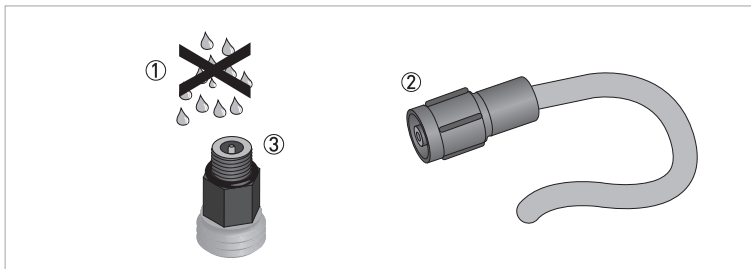

Figure 4-1: Connecting the cable to the sensor

Connecting the cable to the sensor (only for sensor with 4-pin military connector)

- Ensure that the cable and the sensor connector are absolutely dry ①.
- Screw the cable connector ② on to the sensor connector ③ and tighten it by hand.

4.3 Connecting the sensor cable to the MAC 100

All work on the electrical connections may only be carried out with the power disconnected. Take note of the voltage data on the nameplate!

Look at the device nameplate to ensure that the device is delivered according to your order.

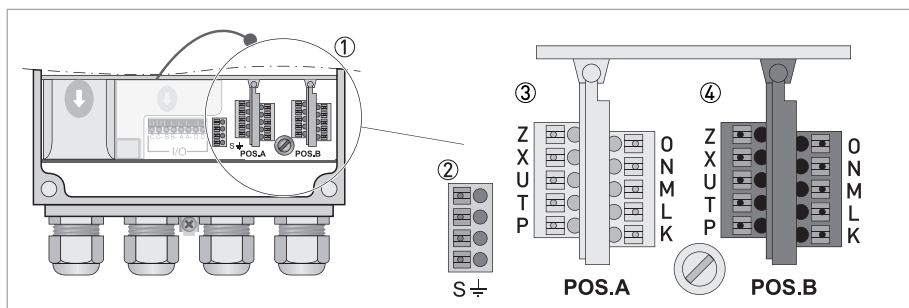

Figure 4-2: Sensor connection terminals on the MAC 100 dual channel version

- ① Sensor connection terminals
- ② Terminal block S (protective earth)
- ③ Terminal block Pos.A: terminal for sensor and temperature
- ④ Terminal block Pos.B: terminal for sensor and temperature

MAC 100 single channel version is equipped only with terminal block Pos. A.

MAC 100 dual channel version is equipped with terminal block Pos. A and Pos. B.

Wire	Terminal block Pos.A/B
Black (inner coax shield)	N (ref.)
Transparent (coax core)	O (pH / ORP)
White (Pt100)	P
Red (Pt100)	X

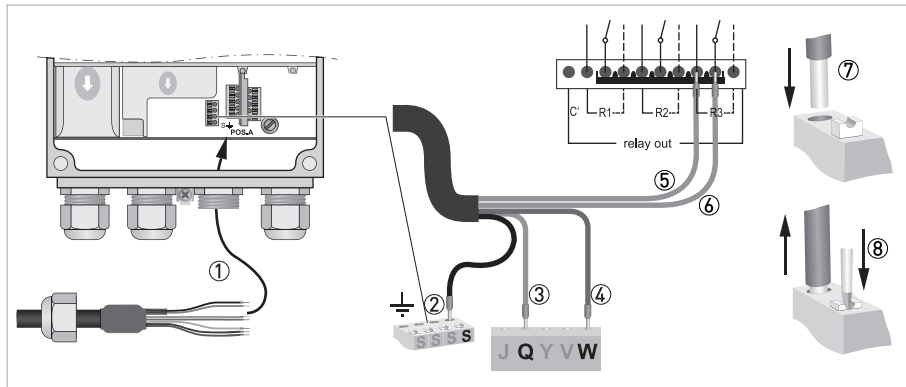

Figure 4-3: Connecting the sensor cable

The following instructions describe the connection of the sensor cable.

Connecting the sensor cable to the signal converter

- Thread the sensor cable through the outer right cable gland ①.
- Push the black wire (inner coax shield) ④ into terminal N ② and the transparent wire [coax core] into terminal O ③.
- To remove a wire, press down the white clip ⑤ on the corresponding terminal and pull the wire out ⑥.

4.4 Connecting the external temperature sensor

Connect an external Pt100 or Pt1000 sensor to terminal block Pos.A/B of the signal converter according to the following drawings:

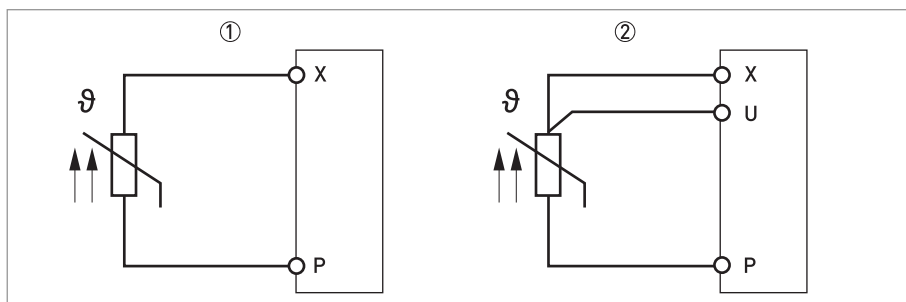

Figure 4-4: Connection of an external Pt100/1000 temperature sensor to the signal converter

- ① 2-wire connection
- ② 3-wire connection

5.1 Order code

The characters of the order code highlighted in light grey describe the standard.

VGA U	4	Sensor type	
	1	OPTISENS PH 8590	
		Measuring range	
	1	0...14 pH	
		Diaphragm	
	1	Ceramic	
		Reference	
	1	KCl gel double junction	
		Body material	
	1	CPVC	
		Glass	
	1	General purpose glass	
		Process conditions	
	1	-5...+80°C, max. 5.9 bar at +25°C / +23...+176°F, max. 85 psi at +140°F	
		Process connection	
	1	3/4" NPT (male)	
		Insertion length	
	1	23 mm / 0.91"	
	2	44 mm / 1.73"	
		Sensor features	
	1	Standard	
		Sensor option	
	1	Pt100	
Carried forward		Continued next page	

		Connector type	
		1	Attached cable
		2	4-pin military connector
		Cable	
		0	None
		1	Cable pH/ORP-W US
		Cable features	
		0	None
		1	Coax, single screen
		Cable length	
		0	None
		2	7.62 m / 25 ft.
		3	10 m / 33 ft.
		Cable options	
		0	None
		2	Core sleeves ends
		Documentation	
		0	None
		1	English
		2	German
3	French		
4	Spanish		
VGA U	4		

5.2 Accessories

Consumables	Order code
250 ml buffer solutions pH4	XGA S 010020
250 ml buffer solutions pH7	XGA S 010030

Accessories	Order code
SENSOFIT FLOW 1000 Flow-through assembly	Please see technical datasheet SENSOFIT FLOW 1000
SENSOFIT FLOW 1710 Flow-through assembly	Please see technical datasheet SENSOFIT FLOW 1710
SENSOFIT IMM 2000 Immersion assembly	Please see technical datasheet SENSOFIT IMM 2000
SENSOFIT IMM 2920 Immersion assembly	Please see technical datasheet SENSOFIT IMM 2920
OPTISENS cable PH/ORP-W-US-4P-25 for 4 pin military connector, 7.62 m / 25 ft.	XGA W 0 12221
OPTISENS cable PH/ORP-W-US-4P-33 for 4 pin military connector, 10 m / 33 ft.	XGA W 0 12261



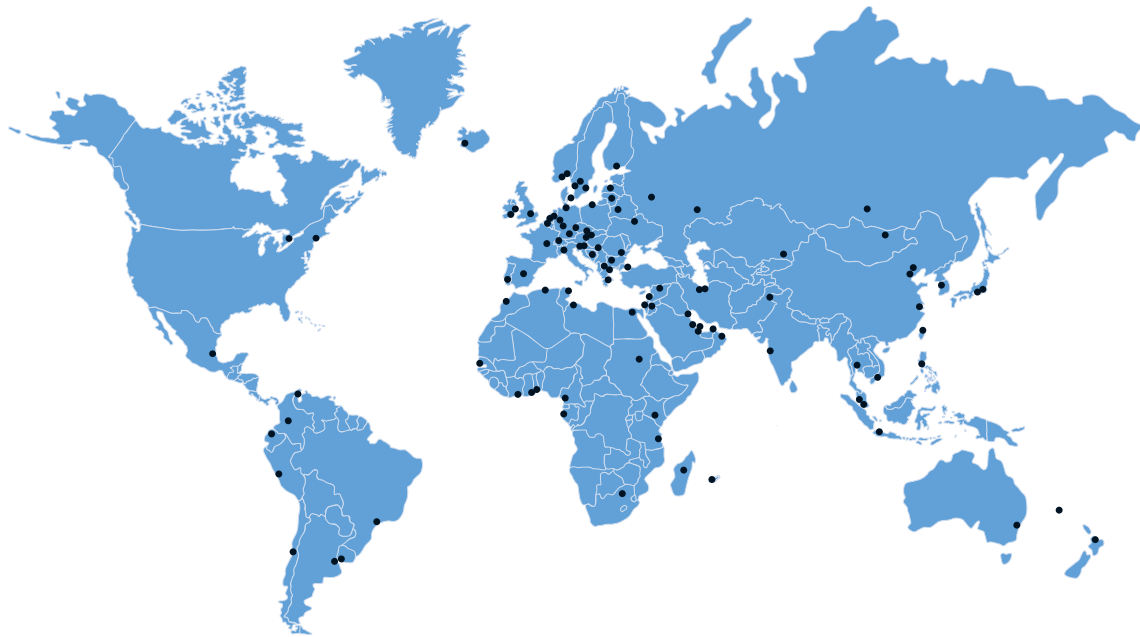

KROHNE product overview

- Electromagnetic flowmeters
- Variable area flowmeters
- Ultrasonic flowmeters
- Mass flowmeters
- Vortex flowmeters
- Flow controllers
- Level meters
- Temperature assemblies
- Pressure transmitters
- Analysis products
- Products and systems for the oil & gas industry
- Measuring systems for the marine industry

Head Office KROHNE Messtechnik GmbH
Ludwig-Krohne-Str. 5
47058 Duisburg (Germany)
Tel.: +49 203 301 0
Fax: +49 203 301 103 89
info@krohne.com

The current list of all KROHNE contacts and addresses can be found at:
www.krohne.com

KROHNE