



OPTISENS PH 8100 **Technical Datasheet**

pH sensor

- High quality and precise glass sensor for usage in low conductivity media
- High temperature resistency
- Suitable for application in chemical industry

The documentation is only complete when used in combination with the relevant documentation for the signal converter.

| | | |
|----------|--|-----------|
| 1 | Product features | 3 |
| <hr/> | | |
| 1.1 | pH sensor for water applications | 3 |
| 1.2 | Design and options | 5 |
| 1.3 | pH measurement..... | 7 |
| 2 | Technical data | 9 |
| <hr/> | | |
| 2.1 | Technical data..... | 9 |
| 2.2 | Dimensions | 11 |
| 2.3 | Combination sensor/signal converter | 12 |
| 3 | Installation | 13 |
| <hr/> | | |
| 3.1 | General notes on installation | 13 |
| 3.2 | Intended use | 13 |
| 3.3 | Pre-installation requirements | 13 |
| 3.4 | Installing the sensor..... | 15 |
| 3.4.1 | General installation instructions..... | 15 |
| 3.4.2 | Mounting to a flow-through assembly | 16 |
| 3.5 | Examples of a typical measuring point..... | 17 |
| 4 | Electrical connections | 18 |
| <hr/> | | |
| 4.1 | Safety instructions..... | 18 |
| 4.2 | Connecting the cable to the sensor | 18 |
| 4.3 | Connecting the sensor cable to the signal converter..... | 19 |
| 4.4 | Connecting the external temperature sensor | 20 |
| 5 | Order information | 21 |
| <hr/> | | |
| 5.1 | Order code | 21 |
| 5.2 | Spare parts, consumables and accessories | 22 |
| 6 | Notes | 23 |
| <hr/> | | |

1.1 pH sensor for water applications

The **OPTISENS PH 8100** sensor is characterised by standardised design, easy handling and a long life cycle. In combination with the MAC 100 signal converter it is possible to create an extremely reliable and low-cost measurement system, which is suitable for a wide range of water analysis measurement tasks.

Designed as combined electrodes with built-in reference electrode the **OPTISENS PH 8100** sensor type is equipped with two open diaphragms and integrated temperature sensor Pt100. The sensor can be easily adapted to various application requirements and it is extremely service friendly and durable.

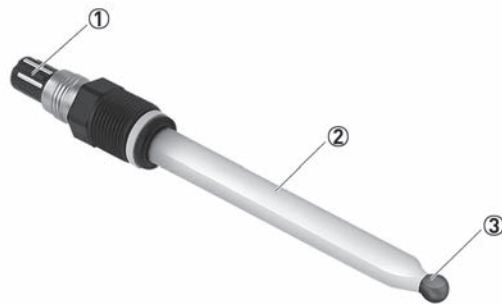

- ① Process connection VP 8.0
- ② Glass shaft with built-in reference electrode and KCl gel filling
- ③ Measuring electrode: H glass

Highlights

- Clog free open diaphragm (in the form of a glass capillary) for faster response time and more accurate readings
- Special reference systems for extended lifetime and wide application range
- Optional with integrated Pt100 for temperature compensation
- Wide temperature range up to 130°C / 266°F
- Various mounting assemblies for easy installation and reliable handling
- Suitable for connection to the MAC 100 signal converter

Industries

- Water industry
- Power plants
- Chemicals

Applications

- Quality control of water (including steam and cooling water)
- Process control
- Dosage of flocculation agents
- Wastewater applications

1.2 Design and options

MAC 100 Multiparameter signal converter for liquid analytical measurements



A complete measuring system consists of:

- MAC 100 Multiparameter signal converter
- 1 or 2 sensors
- Mounting assemblies

Up to two sensors (for identical or different parameters) can be connected to the signal converter.

The signal converter MAC 100 can be adapted perfectly for your requirements: you specify the number and type of signal inputs and outputs, you define the complexity of the measuring point and the number of parameters. The standardised user interface also speeds up commissioning of the device and opens access to a wide range of diagnostic functions for devices and processes.

OPTISENS PH 8100



The OPTISENS PH 8100 sensor is manufactured using highly sensitive special glass which can be used in various applications due to its wide temperature range.

Made to Fit

Mounting assemblies SENSOFIT 1000/2000

As a complete provider for water analysis, we naturally offer a complete range of assemblies. In addition to immersion assemblies, there is also a range of flow-through assemblies and adapters for process connections in a wide range of materials. Special versions for special operating conditions are available on request.

For the OPTISENS PH 8100 sensor type the following individual assemblies are available:

- SENSOFIT FLOW 1000 flow-through holder
- SENSOFIT IMM 1000 immersion holder
- SENSOFIT INS 1000 insertion screw-in adapter
- SENSOFIT RET 1000/2000 retractable holder (in preparation)

For further information please consider the technical datasheets.

1.3 pH measurement

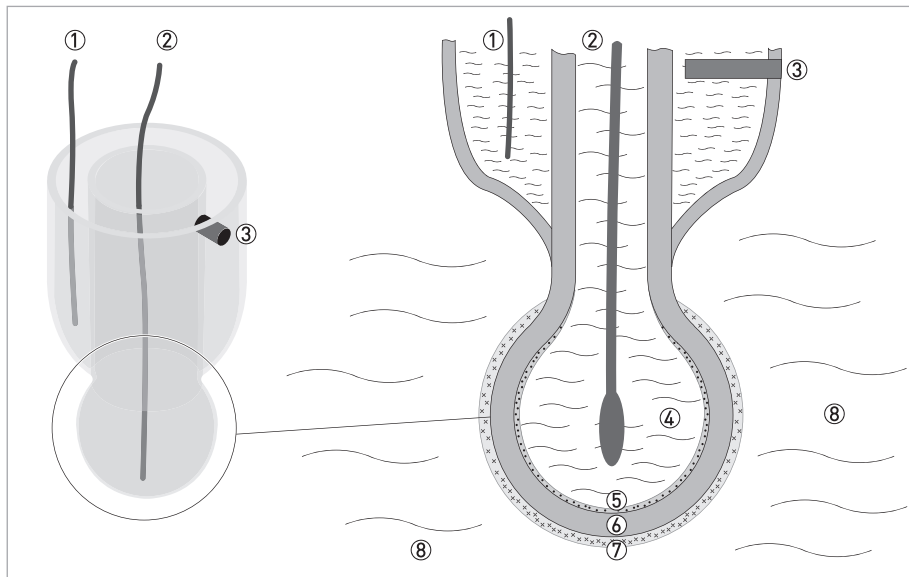

Figure 1-1: Measuring principle for pH measurement

- ① Reference electrode
- ② Measuring electrode
- ③ Diaphragm in contact with KCl solution and measuring medium
- ④ Inner pH 7 buffer solution
- ⑤ Surface potential on the inside [contact with buffer solution]
- ⑥ pH sensitive glass (membrane glass)
- ⑦ Surface potential on the outside [contact with measuring medium]
- ⑧ Measuring medium

The measuring principle of a pH sensor is based on a membrane glass (pH sensitive glass). When the membrane glass gets into contact with a liquid, a thin layer of hydrated gel develops on the surface, enabling an ion exchange between the glass surface and the liquid. The so-called Nernst potential builds up on the glass surface. If both sides of the glass are in contact with liquids, a voltage may be detected between the two surface potentials. The voltage correlates to the difference in H^+ ion concentration and thus to the difference of pH values in both liquids.

The pH sensor contains an internal buffer solution with a known pH value. If the pH value of the measuring medium on the outside of the sensor is equal to the pH value of the inner buffer, the resulting voltage is 0 V.

If the pH value of the medium differs from the internal pH value, a voltage between the internal and the external layer can be measured. From the resulting voltage, the pH difference of the two liquids can be calculated.

The voltage is measured using a measuring electrode and a reference electrode; both are built into the sensor. The measuring electrode is in contact with the known buffer solution in the pH sensitive glass bulb. The reference electrode is immersed into a saturated solution of potassium chloride (KCl). The KCl solution itself is in electrical contact with the measuring medium by means of a diaphragm. The diaphragm prevents the measuring medium from penetrating into the reference system but still allows electrical contact with the measuring medium.

The voltage change of a pH sensor at 25°C / 77°F is around 59 mV for each pH unit. This is also called the slope of the pH sensor. The slope is temperature dependent and decreases over life time of the sensor.

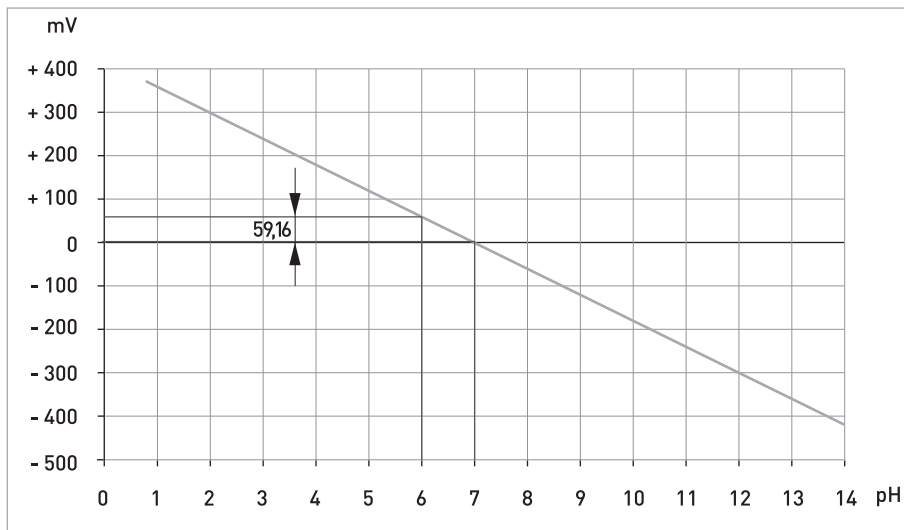

Figure 1-2: Optimal slope at 25°C / 77°F

To compensate for the temperature dependency of the pH measurement, the temperature of the medium can be measured and automatically compensated in the signal converter.

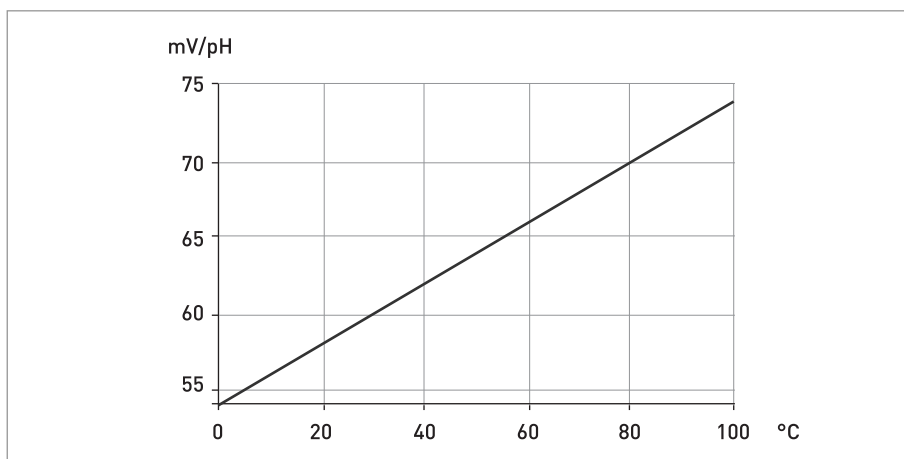

Figure 1-3: Temperature dependency of the Nernst Factor (theoretical slope of a pH sensor)

2.1 Technical data

- *The following data is provided for general applications. If you require data that is more relevant to your specific application, please contact us or your local sales office.*
- *Additional information (certificates, special tools, software,...) and complete product documentation can be downloaded free of charge from the website (Downloadcenter).*

Measuring system

| | |
|---------------------|----------------|
| Measuring principle | Potentiometric |
| Measuring range | 0...14 pH |

Design

| | |
|--------------------|----------------|
| Construction | Glass sensor |
| Shaft diameter | 12 mm / 0.47" |
| Length | 120 mm / 4.72" |
| Process connection | PG 13.5 |
| Temperature sensor | Pt100 |
| Sensor cap | VP 8.0 |
| Type of diaphragm | 2 x open |

Measuring accuracy

| | |
|-------------------------|---|
| Reference conditions | Medium: water |
| | Temperature: 20°C / 68°F |
| | Pressure: 1 bar / 14.5 psi (absolute) |
| Maximum measuring error | pH: 0.2% full scale |
| | Temperature : 1.0% full scale |
| Repeatability | 0.2% full scale |
| Resolution | 0.1 (or 0.01 in extended mode) |
| Long-term stability | 24 hours: tested within accuracy definition |
| Temperature drift | Tested within accuracy definition |
| Cable length variation | Tested within accuracy definition |

Operating conditions

| | |
|-------------------------|-----------------------------|
| Temperature range | 0...+130°C / +32...+266°F |
| Max. operating pressure | 10 bar / 145 psi (absolute) |
| Minimum conductivity | > 2 µS/cm |

Installation conditions

| | |
|----------------------------|---|
| Process connection | PG 13.5 |
| Immersion holder | SENSOFIT IMM 1000 |
| Flow-through holder | SENSOFIT FLOW 1000 |
| Insertion screw-in adapter | SENSOFIT INS 1000 |
| Retractable holder | SENSOFIT RET 1000/2000 (in preparation) |

Materials

| | |
|-----------------------|----------------|
| Sensor shaft | Glass |
| Measuring electrode | H Glass |
| Inner buffer | pH 7.0 |
| Reference electrolyte | Polisolve Plus |
| Diaphragm | 2 x open |
| Gasket | EPDM |

Electrical connection

| | |
|--------------|---------------------------------|
| Connector | VP 8.0 |
| Cable | Cable PH/ORP-W VP 8.0 |
| Cable length | 5 m / 16.4 ft or 10 m / 32.8 ft |

For further information contact your local sales office.

2.2 Dimensions

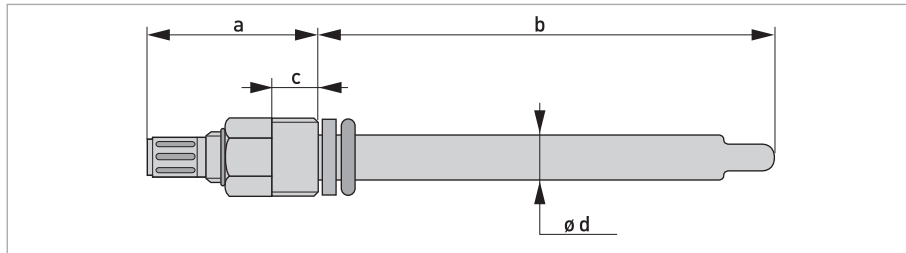

Figure 2-1: Dimension of OPTISENS PH 8100

| | Dimensions [mm] | Dimensions [inch] |
|---|-----------------|-------------------|
| a | 52 | 2.0 |
| b | 120 | 4.7 |
| c | 12 | 0.5 |
| d | Ø 12 | Ø 0.5 |

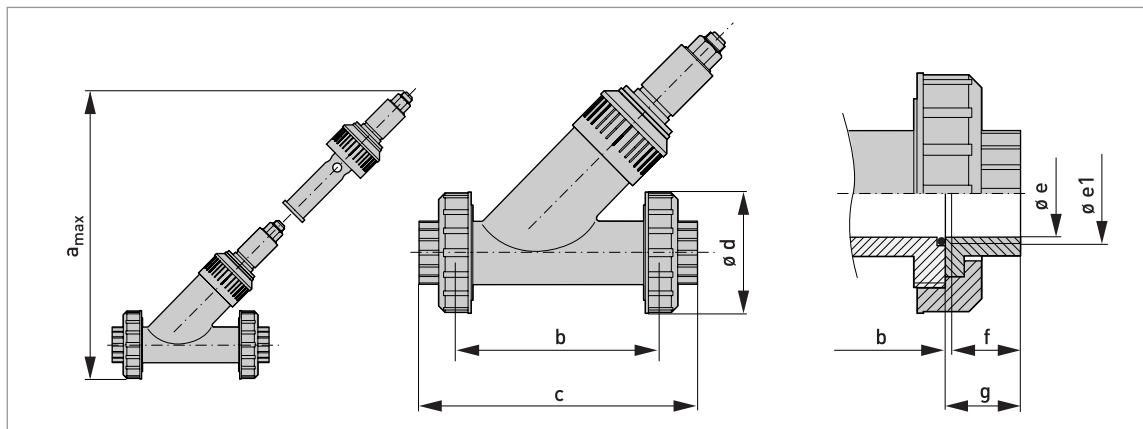

Figure 2-2: Dimensions SENSOFIT FLOW 1000

| | Dimensions [mm] | Dimensions [inch] |
|------------------|-----------------|-------------------|
| a _{max} | 165 | 6.5 |
| b | 142.5 | 5.61 |
| c | 178.5 | 7.03 |
| d | Ø 75 | Ø 2.95 |
| e | Ø 21 | Ø 0.83 |
| e1 | G1 | G1 |
| f | 19.1 | 0.75 |
| g | 22 | 0.87 |

2.3 Combination sensor/signal converter

| Sensor type | Measured parameter | Measuring principle | Signal converter | |
|------------------|---------------------------------------|---------------------|------------------|---------|
| | | | Input A | Input B |
| pH | pH value | Potentiometric | X | X |
| ORP | ORP value | Potentiometric | X | X |
| Cl ₂ | Free chlorine | Amperometric | X | - |
| ClO ₂ | Chlorine dioxide | Amperometric | X | - |
| O ₃ | Ozone | Amperometric | X | - |
| DO | Dissolved oxygen | Amperometric ① | X | - |
| | | Optical ① | X | - |
| COND | Conductivity/ specified resistance | Conductive | X | X |
| IND | Toroidal conductivity | Inductive | X | X |
| TUR | Turbidity | Optical ① | X | - |

① only for single channel version

3.1 General notes on installation

Inspect the packaging carefully for damages or signs of rough handling. Report damage to the carrier and to the local office of the manufacturer.

Do a check of the packing list to make sure that you have all the elements given in the order.

Look at the device nameplate to ensure that the device is delivered according to your order. Check for the correct supply voltage printed on the nameplate.

3.2 Intended use

Responsibility for the use of the measuring devices with regard to suitability, intended use and corrosion resistance of the used materials against the measured fluid lies solely with the operator.

The manufacturer is not liable for any damage resulting from improper use or use for other than the intended purpose.

The intended use of OPTISENS PH 8100 sensor is the measurement of pH in water liquids. The sensor is suitable for connection to the MAC 100 signal converter.

3.3 Pre-installation requirements

- *Do not drop the device! Handle the device with care!*
- *Never touch or scratch the pH membrane glass of the sensor.*
- *Store the sensor in its original packaging in a dry, dust-free location. Keep it away from dirt. If necessary, clean it as described in the manual of the sensor.*
- *Do not make any mechanical modifications to the sensor (electrodes shortened, drilled, bent or scratched). This can result in the loss of proper functionality, as well as the rights under the device warranty.*
- *The sensor must be suitable for the temperature, pressure and medium conditions which are specified (including chemical resistance).*

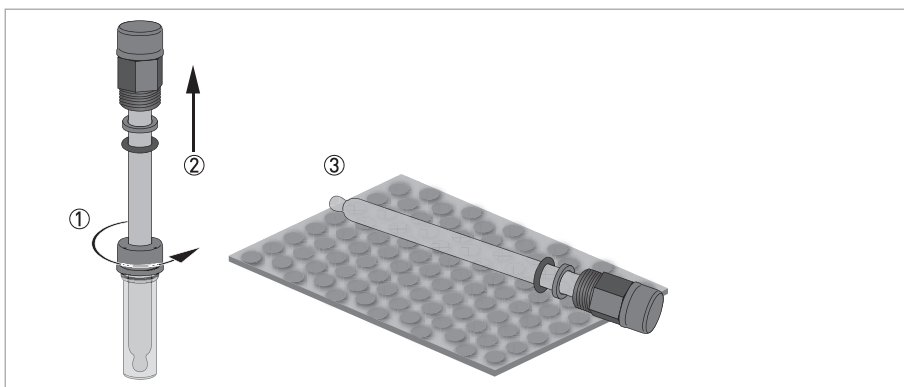

Figure 3-1: Handling the sensor

Unpacking the sensor

- Loosen the storage cap which is screwed or/and pushed on to the plastic tube ①.
- Gently pull the sensor out of the plastic tube ②.
- Lay the sensor on a soft mat/tissue ③.

3.4 Installing the sensor

3.4.1 General installation instructions

The sensor tip must always have full contact with the measuring medium.

The mounting position of the sensor should not deviate more than 75° from vertical position (sensor tip pointing downwards). Doing otherwise might cause internal air bubbles to float into the sensor tip. This would interrupt the electrical contact between the inner buffer solution and the glass surface.

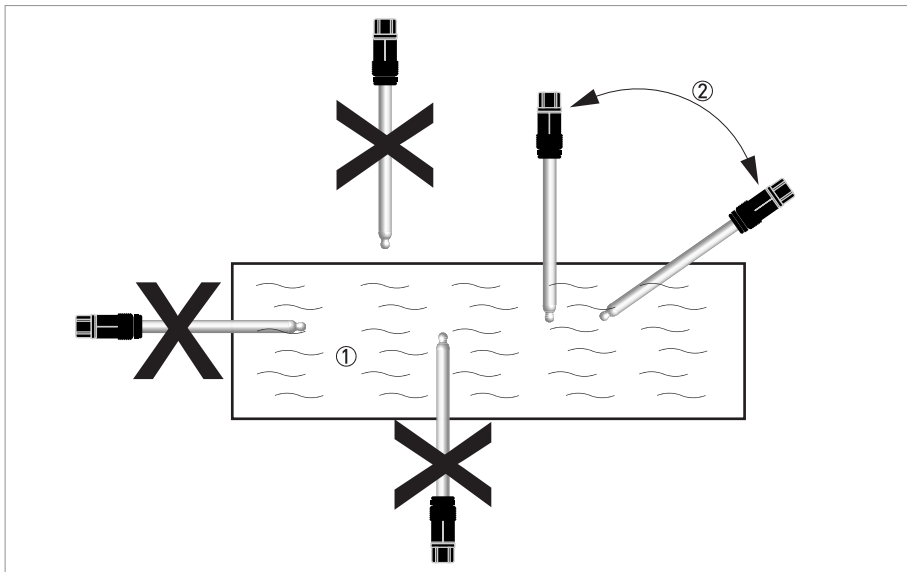

Figure 3-2: Installation requirements

- ① Measuring medium
- ② Maximum deviation of 75° from vertical position

3.4.2 Mounting to a flow-through assembly

Ensure that the pipe is without pressure before installing or removing a sensor!

The flow-through assembly is an optional accessory and not part of the standard scope of delivery. It has to be installed horizontally in pump or sample lines or directly in the process.

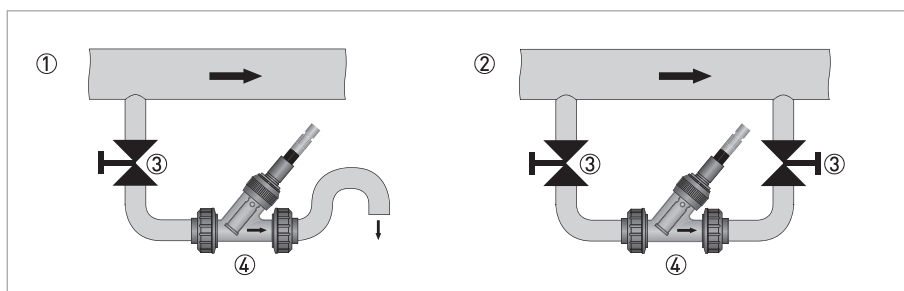

Figure 3-3: Possible mounting positions of the flow-through assembly

- ① Mounting in an outlet pipe
- ② Mounting in a bypass pipe
- ③ Valve
- ④ Flow-through assembly

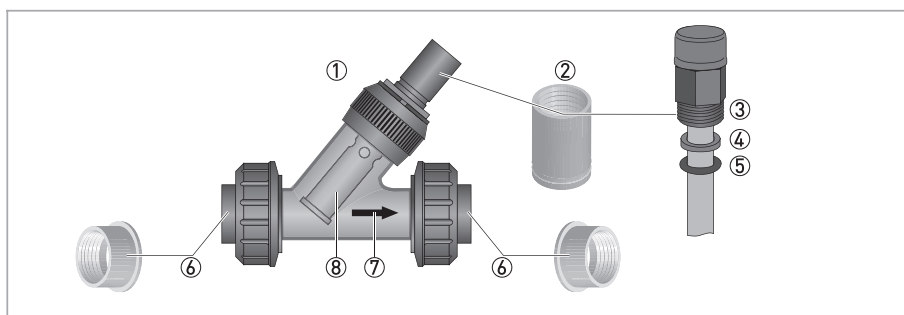

Figure 3-4: Installing the sensor into the flow-through assembly

- ① Flow-through assembly
- ② Female thread
- ③ Sensor thread
- ④ Washer
- ⑤ O-ring
- ⑥ Process connection
- ⑦ Flow direction
- ⑧ Protective cage

Installing a new sensor

- Make sure that the O-ring ⑤ and the washer ④ on the sensor are assembled in the sequence indicated in the drawing.
- Screw the sensor into the female thread ② of the flow-through assembly ①. Tighten the sensor by hand.
- If you have not yet established the electrical connection to the signal converter, leave the protective cap on the sensor until you establish the electrical connection.

3.5 Examples of a typical measuring point

The following examples each show the signal converter, a sensor with or without integrated temperature measurement, and the flow-through or immersion assembly.

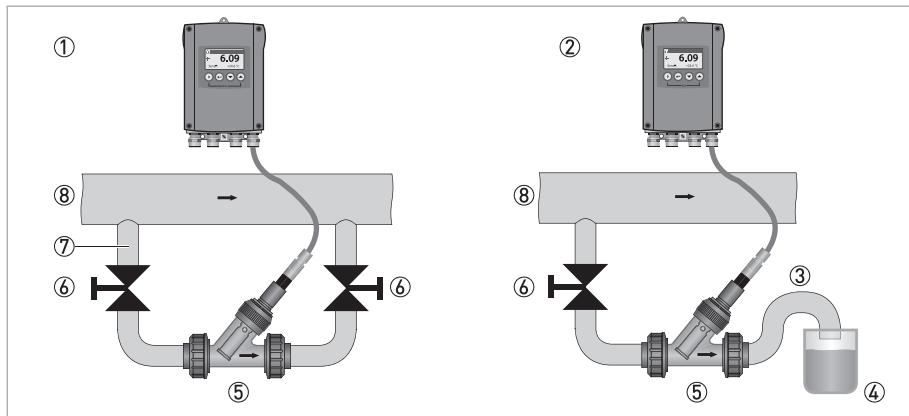

Figure 3-5: Measuring point using the flow-through assembly

- ① Bypass measurement
- ② Outlet measurement
- ③ Elbow pipe
- ④ Sample vial
- ⑤ Flow-through assembly with sensor
- ⑥ Shut-off valve
- ⑦ Bypass pipe
- ⑧ Main pipe

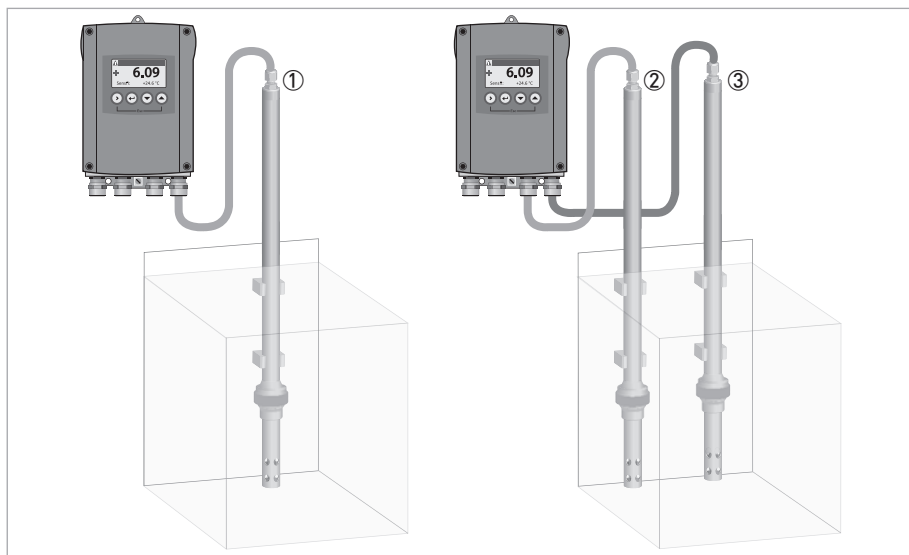

Figure 3-6: Measuring point using the immersion assembly

- ① pH and temperature on single channel instrument
- ② pH or pH and temperature
- ③ pH and temperature

4.1 Safety instructions

All work on the electrical connections may only be carried out with the power disconnected. Take note of the voltage data on the nameplate!

Observe the national regulations for electrical installations!

Observe without fail the local occupational health and safety regulations. Any work done on the electrical components of the measuring device may only be carried out by properly trained specialists.

Look at the device nameplate to ensure that the device is delivered according to your order. Check for the correct supply voltage printed on the nameplate.

4.2 Connecting the cable to the sensor

Moisture on the sensor connector must be avoided! Moisture may cause a short-circuit and a malfunction of the sensor!

If moisture has entered the connector dry it with air (e.g. hot air gun).

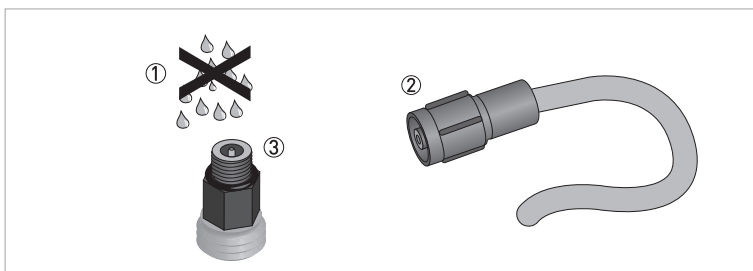

Figure 4-1: Connecting the cable to the sensor

Connecting the cable to the sensor

- Ensure that the cable and the sensor connector are absolutely dry ①.
- Screw the cable connector ② on to the sensor connector ③ and tighten it by hand.

4.3 Connecting the sensor cable to the signal converter

All work on the electrical connections may only be carried out with the power disconnected. Take note of the voltage data on the nameplate!

Look at the device nameplate to ensure that the device is delivered according to your order. Check for the correct supply voltage printed on the nameplate.

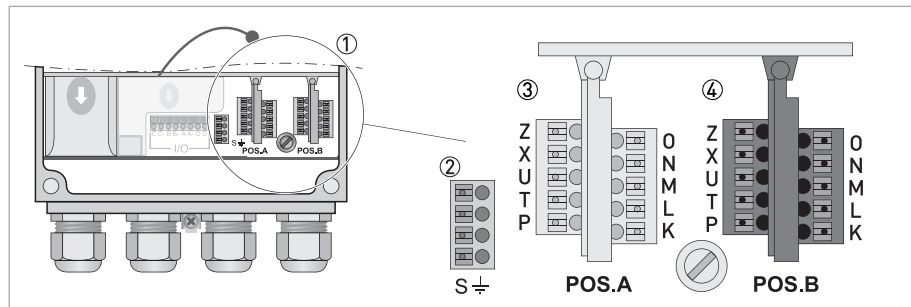

Figure 4-2: Sensor connection terminals on the MAC 100 dual channel version

- ① Sensor connection terminals
- ② Terminal block S (protective earth)
- ③ Terminal block Pos.A: terminal for sensor and temperature
- ④ Terminal block Pos.B: terminal for sensor and temperature

The pH sensors are available with integrated Pt100 temperature sensor. The pH sensors with integrated temperature sensor use a VP 8.0 cable.

When ordering the one channel version, only the interface "Pos.A" is populated. In the version with two channels the interfaces "Pos.A" and "Pos.B" are populated.

| Wire | Terminal block Pos.A/B |
|--|------------------------|
| OPTISENS PH 8100 with VP 8.0 cable (with integrated Pt100/1000) | |
| Inner coax shield (black) | N (ref.) |
| Coax core (transparent) | O (pH) |
| Sense (3-wire connection Pt100/Pt1000) | U |
| Pt100 (white) | P |
| Pt100 (green) | X |
| Outer shield (green-yellow) | S |

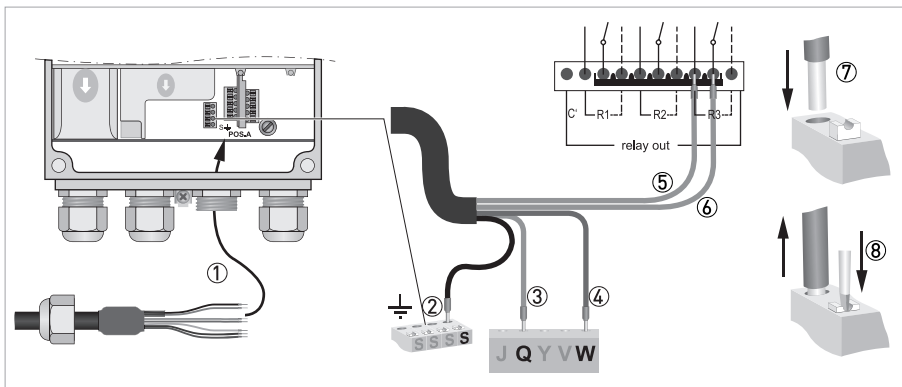

Figure 4-3: Connecting the sensor cable

The following instructions describe the connection of the different sensor cables.

Connecting the sensor cable to the signal converter

- Thread the sensor cable through the outer right cable gland ①.
- Push the coax shield ④ into terminal N ② and the coax core into terminal O ③.
- To remove a cable, press down the white clip ⑤ on the corresponding terminal and pull the cable out ⑥.

4.4 Connecting the external temperature sensor

Connect an external Pt100 or Pt1000 sensor to terminal block Pos.A/B of the signal converter according to the following drawings:

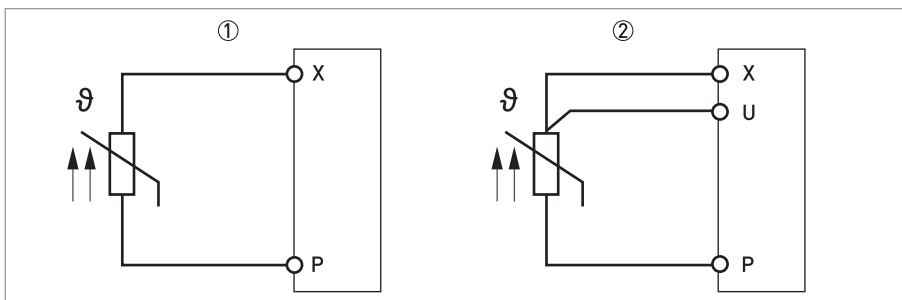

Figure 4-4: Connection of an external Pt100/1000 temperature sensor to the signal converter (2-wire connection)

- ① 2-wire connection
- ② 3-wire connection

5.1 Order code

The characters of the order code highlighted in light grey describe the standard.

| | | | |
|-------|---|---|--|
| VGA P | 4 | Sensor type | |
| | 1 | OPTISENS PH 8100 | |
| | | Measuring range | |
| | 1 | 0... 14 pH | |
| | | Diaphragm | |
| | 1 | open | |
| | | Reference | |
| | 7 | Polisolve Plus | |
| | | Body material | |
| | 1 | Glass | |
| | | Glass | |
| | 7 | H-Glass | |
| | | Process conditions | |
| | 7 | 0...+130°C / +32...+266°F, 6 bar / 87 psi | |
| | | Process connection | |
| | 1 | PG 13.5 mounting kit | |
| | | Insertion length | |
| | 3 | 120 mm / 4.7" | |
| | | Sensor features | |
| | 7 | 2 x micro pore | |
| | | Sensor option | |
| | 2 | incl. Pt100 | |
| | | Connector type | |
| | 7 | Vario Pin (VP) | |
| | | Documentation | |
| | 0 | none | |
| | 1 | English | |
| | 2 | German | |
| | 3 | French | |
| | 4 | Spanish | |
| VGA P | 4 | | |

5.2 Spare parts, consumables and accessories

| Spare parts | Order code |
|------------------|-----------------------|
| OPTISENS PH 8100 | VGA P 4 1117177137270 |

| Consumables | Order code |
|--------------------------------|--------------|
| 250 ml pH buffer solutions pH4 | XGA S 010020 |
| 250 ml pH buffer solutions pH7 | XGA S 010030 |

| Accessories | Order code |
|---|--|
| SENSOFIT FLOW 1000 flow-through holder | Please see technical datasheet SENSOFIT FLOW 1000 (in preparation) |
| SENSOFIT IMM 1000 immersion holder | Please see technical datasheet SENSOFIT IMM 1000 (in preparation) |
| SENSOFIT INS 1000 insertion screw-in adapter | Please see technical datasheet SENSOFIT INS 1000 (in preparation) |
| SENSOFIT RET 1000/2000 retractable (in preparation) | Please see technical datasheet SENSOFIT RET 1000/2000 (in preparation) |
| Cable PH/ORP-W Sensor VP 8.0 with temp. wire 5 m / 16.5 ft | XGA W 0 18851 |
| Cable PH/ORP-W Sensor VP 8.0 with temp. wire 10 m / 33 ft | XGA W 0 18861 |



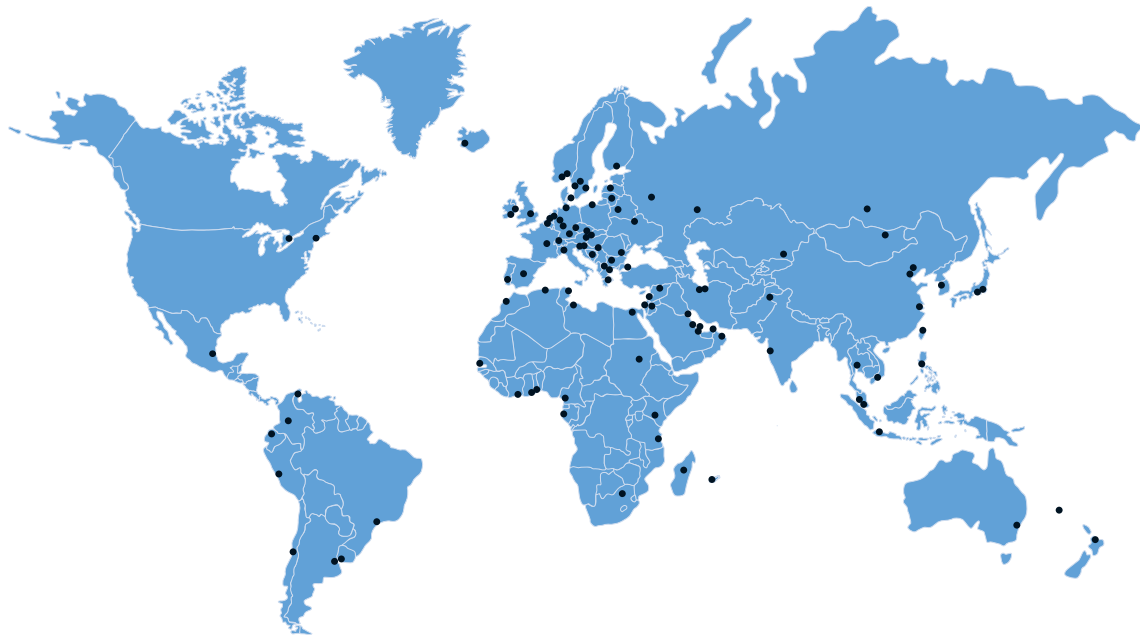

KROHNE – Process instrumentation and measurement solutions

- Flow
- Level
- Temperature
- Pressure
- Process Analysis
- Services

Head Office KROHNE Messtechnik GmbH
Ludwig-Krohne-Str. 5
47058 Duisburg (Germany)
Tel.: +49 203 301 0
Fax: +49 203 301 10389
info@krohne.com

The current list of all KROHNE contacts and addresses can be found at:
www.krohne.com

KROHNE