



OPTISENS ODO 2000 **Technical Datasheet**

Sensor for dissolved oxygen measurement in water and wastewater

- Rugged design for harsh applications
- Integrated transmitter with direct 4...20 mA output
- Optical disk with luminophore and sun protection

The documentation is only complete when used in combination with the relevant documentation for the signal converter.

1	Product features	3
1.1	Dissolved oxygen sensor for water and waste water application.	3
1.2	Design and options	4
1.3	Measuring principle.....	5
2	Technical data	6
2.1	Technical data.....	6
2.2	Dimensions and weight	8
3	Installation	9
3.1	Installation procedure	9
3.2	Configuration of a measuring point	9
3.3	Sensor use with cleaning function.....	10
3.4	Sensor use without cleaning function.....	11
3.5	Mounting the sensor into an assembly.....	11
4	Electrical connections	12
4.1	Connecting the sensor cable to the signal converter.....	12
4.2	Connecting the sensor directly to the control system.....	14
4.3	Connecting the sensor to PC.....	14
4.4	Connecting the power supply to the signal converter MAC 100.....	15
5	Order information	17
5.1	Order code	17
5.2	Consumables.....	18
6	Notes	19

1.1 Dissolved oxygen sensor for water and waste water application.

Dissolved oxygen measurement is widely used in drinking water and wastewater applications. The oxygen measurement is used for aeration monitoring and control in water and waste water plants.

The optical oxygen sensor OPTISENS ODO 2000 from KROHNE has a standardized robust design for open channel measurement and a long lifespan. The sensor can be deployed in any size of water treatment plants may it be small or big. The integrated spray cleaning nozzle minimize the need for manual cleaning, which means longer intervals between maintenance and calibration.



Figure 1-1: Luminophore disk with flushing nozzle

Highlights

- Precise dissolved oxygen measurement in the ppm range with a resolution of 0.01ppm
- Long-term stability due to reduced clogging by integrated spray cleaning nozzle
- Low cost of ownership due to an integrated transmitter
- Easy changeable optical disk
- Short response time for all applications
- Suitable for installation with telescopic rod SENSOFIT IMM 2000

Industries

- Water and waste water industry

Applications

- Aeration monitoring in water and waste water treatment plants

1.2 Design and options



This submersible oxygen sensor provides a 4...20 mA current loop or a RS485 output.

The serial interface allows commands entered via the hyperterminal of a personal computer, the transmission of the measurement and check signal, the scale selection, the analog or digital operating mode selection, the zero and sensitivity calibration. The sensor is suitable for connection to a signal converter.

The cleaning of the sensing element is performed by the injection of pressurised clean air, provided by the user.

It can be easily adapted to various application requirements and can be installed directly into a basin with a telescopic rod.

1.3 Measuring principle

The application of optical oxygen measurement has been studied extensively since the mid 1980s. The optical oxygen sensor contains an oxygen sensitive dye (fluorophore) that is immobilised in an oxygen permeable polymer matrix layer and in direct contact with the process media.

The fluorophore is excited by the energy-rich blue light emitted by the LED inside the sensor into an excited state. This energy can be emitted from the excited fluorophore after a short period (micro seconds) by emission of low-energy red light. In case an oxygen molecule is getting in contact with the excited fluorophore, the energy can also be transferred from the excited fluorophore in a non-radiative reaction to the oxygen. In that case the intensity of the emitted red light from the polymer matrix layer is decreased (fluorescence quenching). Consequently, the intensity of the emitted red light is decreased with increasing oxygen content. The intensity of the emitted red light is measured with a light detector. The change in intensity is used to measure the oxygen concentration in the process media. To compensate the intensity drift of the light emitting blue LED its intensity is directly measured with a second light detector.

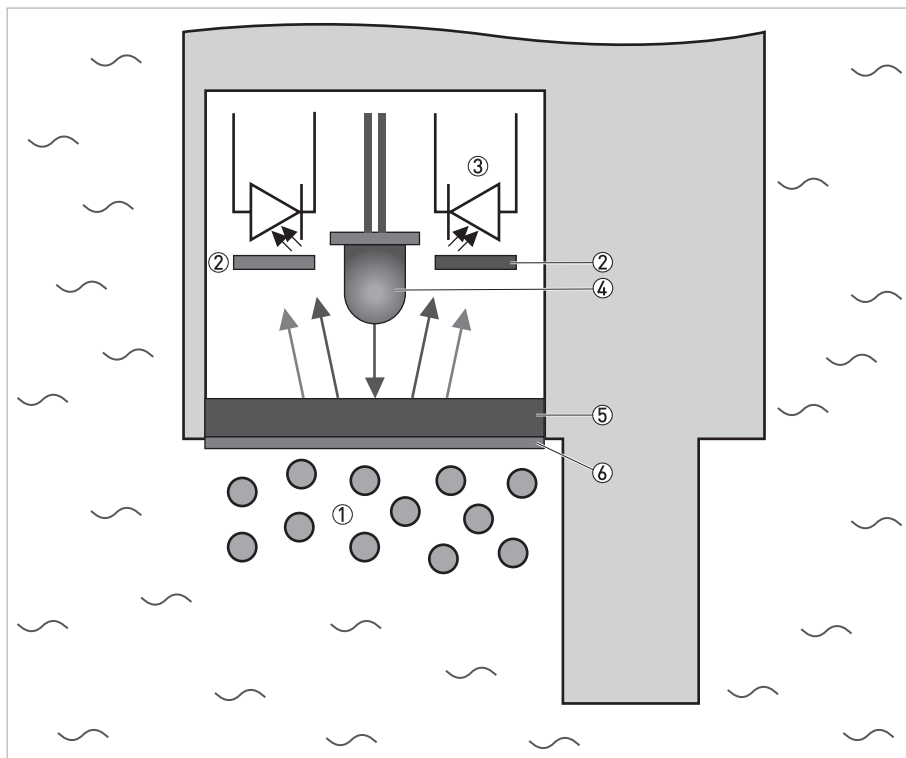

Figure 1-2: Optical measurement of dissolved oxygen

- ① Process media with dissolved
- ② Color filter
- ③ 2 identical light detectors
- ④ LED
- ⑤ Carrier
- ⑥ Fluorescent layer

2.1 Technical data

- *The following data is provided for general applications. If you require data that is more relevant to your specific application, please contact us or your local sales office.*
- *Additional information (certificates, special tools, software,...) and complete product documentation can be downloaded free of charge from the website (Downloadcenter).*

Measuring system

Parameter	Dissolved Oxygen
Measuring principle	Fluorescence

Design

Measuring principle	Optical, luminophore disk
Measuring scale	0...20 mg/l (ppm)
Sensor type	Installation with MAC 100 signal converter or directly to control system via 4...20 mA
Shaft diameter	60 mm / 2.36"
Shaft length	166 mm / 6.5"
Sensor thread	2" NPT
Hose diameter	6.3...9.5 mm / 1/4...3/8"

Operating conditions

Temperature range	-5...50°C / +23...122°F
Pressure range	Max. 1 bar at 25°C / 14.5 psi at 77°F
Measuring range	0...20 mg/l (ppm)
Accuracy	± 0.1 ppm if < 1.0 %ppm / ± 1.0 %sat if < 10.0 %sat ± 0.2 ppm if > 1.0 %ppm / ± 2.0 %sat if > 10.0 %sat
Repeatability	± 0.5% of the scale
Resolution	0.01 ppm
Response time (95%)	large signal (>3% air) 95% < 40 seconds small signal (<3% air) 95% < 120 seconds
Measuring cycle	8 seconds
Drift	< 1% year
Relative humidity	0...95% non condensing
Air pressure cleaning	max. 3 bar / 43.51 psi
Units displayed sensor	mg/l (ppm) or %
Units displayed converter	mg/l (ppm)
Temperature sensor	Pt100

Installation conditions

Ingress conditions	IP68
Weight	Body 420 g / 0.93 lb 10 meter cable 760 g / 1.41 lb

Materials

Sensor body	PVC
-------------	-----

Electrical connection

Cable	10 meter / 32.8 ft. 20 meter / 65.62 ft. 30 meter / 98.43 ft.
Voltage	9...36 VDC
Analog output	4...20 mA loop powered isolated
Load	600 Ohm max. at 24 VDC
Digital output	RS485

Approvals

CE

This device fulfils the statutory requirements of the EC directives. The manufacturer certifies successful testing of the product by applying the CE mark.

Electromagnetic compatibility	EMC Directive 2014/30/EU EN 61326-2-3:2013 EN 55011:2009+A1:2010
-------------------------------	--

2.2 Dimensions and weight

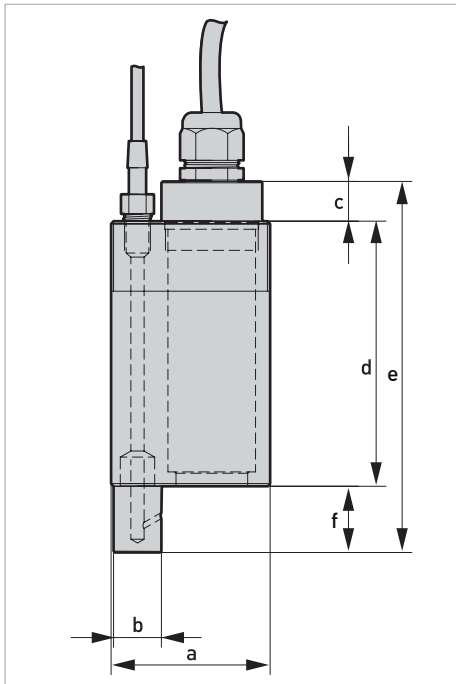

	Dimensions [mm]	Dimensions [inch]
a	60	2,4
b	18	0,71
c	15	0,6
d	100	3,94
e	140	5,51
f	25	0,98

3.1 Installation procedure

A new amperometric dissolved oxygen sensor needs to be calibrated before it is installed into its final measuring location. To install the device in the correct way, follow the order and the following sections and their instructions.

1. Mount the sensor into the immersion assembly. (For further information refer to the manual of the assembly)
2. Connect the sensor to the signal converter or directly to the control system.
3. Configure the measurement range. Calibrate the sensor.
4. Install the sensor into its final measuring location.

3.2 Configuration of a measuring point

The sensor has a 4...20 mA current loop and can be operated with external signal converter or without. If operated without the external converter the converter is needed as configuration and calibration tool.

A complete measuring point consists of at least two or three parts:

- Optional: A signal converter (for configuration only as calibration tool or for operation)
- OPTISENS ODO 2000 sensor (including cable)
- Immersion assembly or other adequate housing

If automatic flushing is installed, an optional solenoid valve is necessary as well.

3.3 Sensor use with cleaning function

Most applications do not require the cleaning function if the sensor is installed correctly in a correct angle.

When the automatic cleaning is required the device can be equipped with a cleaning hose for air cleaning.

Before the device is installed into its final measuring location the following points must be observed

- provide hose (Ø 6.3...9.5 mm / 1/4...3/8") in suitable length
- prepare a connection for the cleaning hose
- push the hose onto the cleaning connector
- put the sensor cable and cleaning hose through the adequate extension pipe of the mounting assembly

The pressurised air is to be provided and must be clean with a max of 3 bar.

The typical cleaning time is 15 seconds and the typical cleaning frequency is 2 times/day, but this will differ from application to application.

3.4 Sensor use without cleaning function

Without a cap on the air line connector the sample might block the cleaning drilling for later use or water might flow into a closed assembly and damage the probe due to later handling.

Before installation and immersion the sensor check the following order:

- Do not install any flexible tubing.
- Install a cap on the air line connector in order to avoid the cleaning drilling to be blocked for later use or water to flow through it into a closed assembly.

3.5 Mounting the sensor into an assembly

All work on the electrical connections may only be carried out with the power disconnected.

Do not turn the cable gland on the sensor this might cause a sensor leak and damage the electronics inside. While mounting or dismounting the sensor, the sensor cable must not be fixed or trapped as this might loosen the water tight gland connection from the sensor.

For further instructions on installation into an immersion assembly refer to the assembly manual.

Use an assembly that does not fix the sensor cable or require the sensor to be screwed into the assembly. If the sensor needs to be screwed for mounting or dismounting make sure that the sensor cable is turned into the same direction.

Installing procedure

- Insert the sensor cable through the immersion assembly.
- Fasten the sensor to the tip of the assembly.
- Connect the wires either to the control system directly (only 4...20 mA) or to the MAC 100 signal converter.

For removing the sensor, repeat the steps above in reverse order.

Calibrate the sensor before installing it into the assembly.

4.1 Connecting the sensor cable to the signal converter

All work on the electrical connections may only be carried out with the power disconnected. Take note of the voltage data on the nameplate!

Look at the device nameplate to ensure that the device is delivered according to your order.

Connect the dissolved oxygen sensor to the MAC100 for optimal configurability and process control due to following features:

- scale selection flexibility
- digital input to hold signals during cleaning process
- easy calibration via zero point and sensitivity adjustment
- set minimum and maximum for alarm relays
- galvanic isolated 4...20 mA outputs
- error current

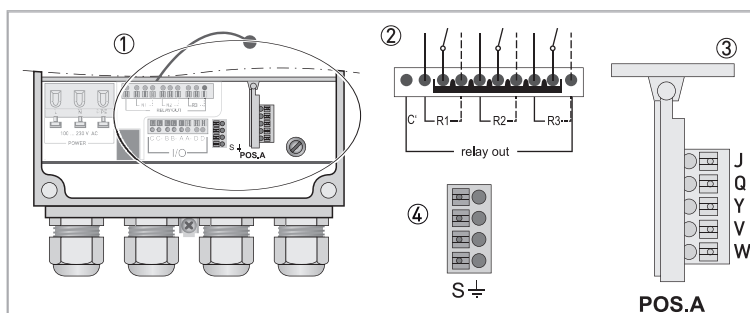

Figure 4-1: Sensor connection terminals on the signal converter MAC 100

- ① Sensor connection terminal
- ② Relays
- ③ Terminal block A: terminals for sensors
- ④ Terminal block S (protective earth)

Wire	Terminal block Pos.A
White	J
Green	Q
Yellow	Y
Grey	V
None	W
brown	not connected

Wire	Terminal S
Metal (non isolated cable)	S

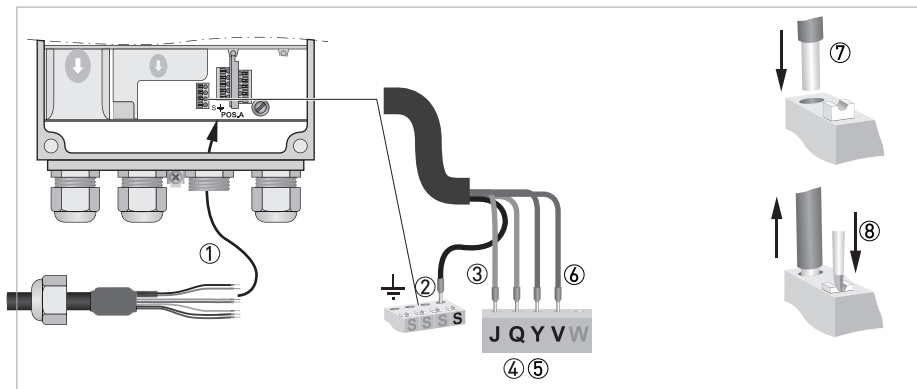

Figure 4-2: Connecting the sensor cable

The following instructions describe the connection of the sensor cable.

Connecting the sensor cable to the signal converter

- Remove the terminal cover.
- Thread the sensor cable through the middle right cable gland ①.
- Push the wires ⑦ into terminal J ③, Q ④, Y ⑤, V ⑥ and S ②.
- To remove a wire, press down the white clip ⑧ on the corresponding terminal and pull the wire out.

4.2 Connecting the sensor directly to the control system

Avoid cable interruptions. If necessary use adequate junction box. Keep the cable far away from power cables inside of the switch board.

The device is loop powered and can be connected directly onto the control system via any junction box.

Wire	Function
Green	+ current loop
White	- current loop
Metal	shield

The normal operation needs just the connection of the green and white wires, which are protected against accidental inversion. The shield is not connected to the probe but it must be connected to the ground.

4.3 Connecting the sensor to PC

Avoid cable interruptions. If necessary use adequate junction box. Keep the cable far away from power cables inside of the switch board.

Connect the device to the converter or directly to the control system as stated in above chapters. The shield is not connected to the probe but it must be connected to the ground.

Wire	Function
Shield	not connected
Yellow	A (+) RS485
Grey	B (-) RS485
Brown	not connected
Green	+ current loop
White	- current loop / COM RS485

4.4 Connecting the power supply to the signal converter MAC 100

The device must be grounded in accordance with regulations in order to protect personnel against electric shocks.

Never install or operate the device in potentially explosive areas, it might cause an explosion that can result in fatal injuries!

When connecting the power supply, always note the safety regulations of the current state of the art. Also note the following items to avoid fatal injuries, destruction or damage of the device or measuring errors:

- *De-energise the cables of the power supply before you start any installation works!*
- *Always keep the housing of the device well closed if you do not perform any installation works. The function of the housing is to protect the electronic equipment from dust and moisture.*
- *Assure that there is a fuse protection for the infeed power circuit ($I_{nom} \leq 16 A$) and a disconnecting device (switch, circuit breaker) to isolate the signal converter.*
- *Check the nameplate and assure that the power supply meets the voltage and frequency of the device. You can operate the device in the range of 100...230 VAC and 8 VA with a tolerance of -15/+10% while 240 VAC +5% is included in the tolerance range (a version with a power supply of 24 VAC/DC is in preparation). A power supply outside these specifications may destroy the device!*
- *Assure that the protective earth conductor (PE) is longer than the L- and N-conductor.*

The manufacturer has designed all creepage distances and clearances according to VDE 0110 and IEC 664 for pollution degree 2. The power supply circuits fulfil the overvoltage category III and the output circuits fulfil the overvoltage category II.

Before you start to connect the power supply cables, note the following drawing with the function of the terminals:

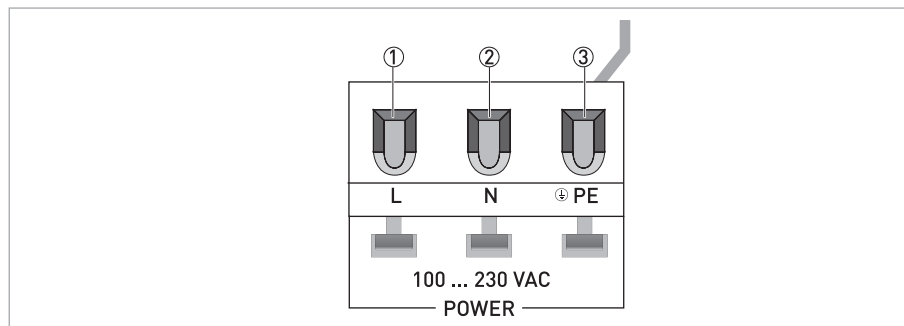

- ① L1...L3 (live)
- ② Neutral
- ③ Protective Earth (PE)

Afterwards connect the power supply cables accordingly:

The manufacturer strongly recommends to use a slotted screwdriver with a tip of 3.5 x 0.5 mm / 0.14 x 0.02" to push down the lever! Otherwise you could damage the lever.

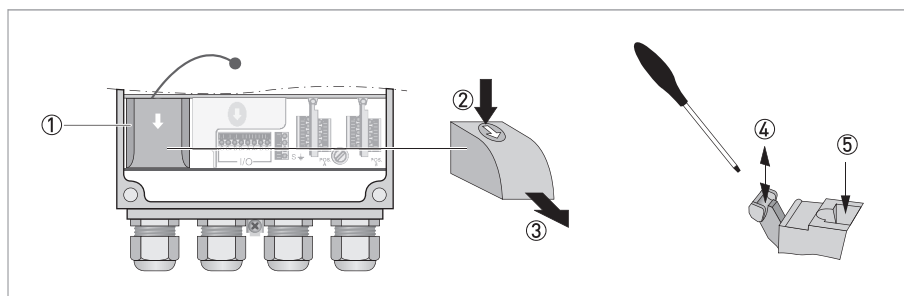

- De-energise the power supply cables with the help of a disconnecting device (switch, circuit breaker)!
- Remove the cover of the power supply terminal (①) by pressing it down and pulling forwards at the same time (② and ③), be careful and do not disrupt the retaining band (it prevents the cover from getting lost)!
- Use a slotted screwdriver with a tip of 3.5 x 0.5 mm / 0.14 x 0.02" to push down the lever, connect the wires to the terminals and pull up the levers again (④ and ⑤).
- Refasten the cover of the power supply terminal, close the converter housing and tighten all screws of the housing.

5.1 Order code

The characters of the order code highlighted in light grey describe the standard.

VGA 0	4	Sensor type	
	A	OPTISENS ODO 2000	
		Measuring range	
	1	0...20 mg/l (ppm)	
		Sensor features	
	A	1 x 4...20 mA / RS485	
		Process conditions	
	1	-5...+50°C, 1 bar at 20°C / +23...+122°F, 14.5 psi	
		Enclosure type	
	B	Submersible	
		Body material	
	1	PVC	
		Process connection	
	A	2" NPT (male)	
		Power supply	
	1	9...36 VDC / loop powered	
		Cable	
	B	Cable-ODO-W 2000	
		Cable features	
	A	Attached cable	
		Cable length	
	3	10 m / 33 ft.	
	4	20 m / 65.6 ft.	
	5	30 m / 98.4	
		Cable options	
	1	Core end sleeve	
		Sensor options	
	1	Flush nozzle	
		Documentation	
	0	none	
	1	English	
	2	German	
	3	French	
	4	Spanish	
VGA 0	4		

5.2 Consumables

Consumables	Order code
Limunophore disk, including mounting tool	XGA S 060050
Sodium sulfite (Na ₂ SO ₃) 1 x 1000 ml	XGA M 040010



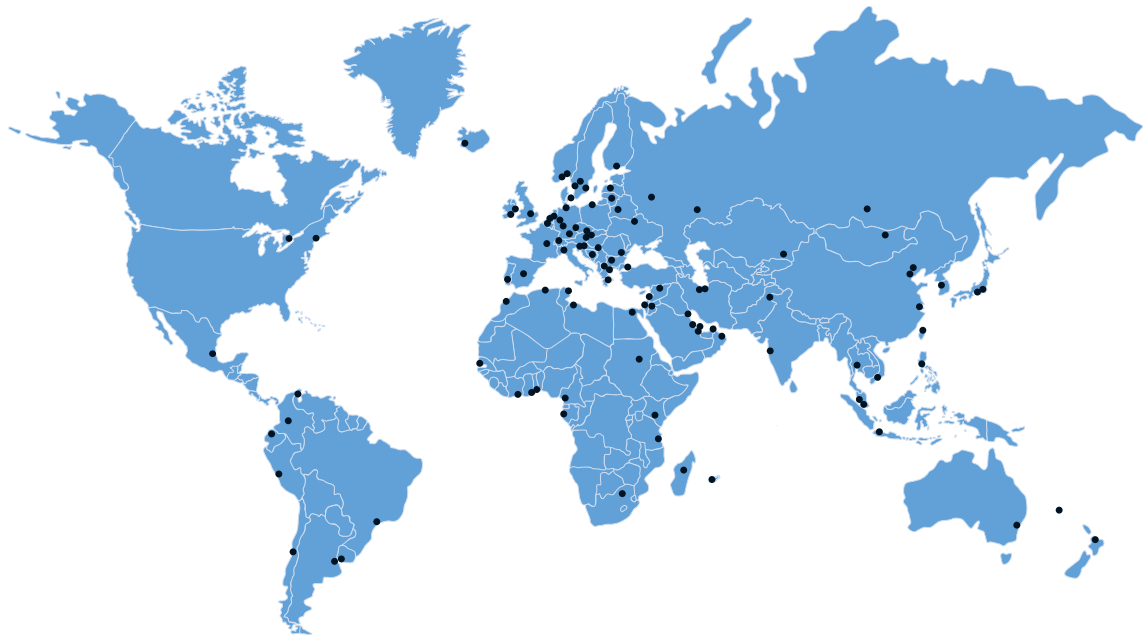

KROHNE – Process instrumentation and measurement solutions

- Flow
- Level
- Temperature
- Pressure
- Process Analysis
- Services

Head Office KROHNE Messtechnik GmbH
Ludwig-Krohne-Str. 5
47058 Duisburg (Germany)
Tel.: +49 203 301 0
Fax: +49 203 301 10389
info@krohne.com

The current list of all KROHNE contacts and addresses can be found at:
www.krohne.com

KROHNE