

OPTIFLEX 8200 C/F/S Technical Datasheet

Guided radar (TDR) level transmitter for liquids at high temperature and pressure

- Level measurement under extreme conditions in the power, oil and gas industries
- Designed for steam boilers
- Single or double ceramic process seal system
- Patented Dynamic Gas-phase Compensation (DGC)

HART
COMMUNICATION PROTOCOL



1	Product features	3
<hr/>		
1.1	The modular TDR level transmitter for steam boilers	3
1.2	Applications	4
1.3	Product family	5
1.4	Application table for probe selection	8
1.5	Measuring principle.....	8
2	Technical data	11
<hr/>		
2.1	Technical data.....	11
2.2	Minimum power supply voltage	20
2.3	Process pressure and process connection temperature limits.....	21
2.4	Measurement limits	24
2.5	Dimensions and weights	28
2.5.1	General notes.....	28
2.5.2	Primary components	28
2.5.3	Signal converter and probe electronics options	29
2.5.4	Process connection options.....	35
2.5.5	Probe options	36
2.5.6	Weather protection option	40
3	Installation	42
<hr/>		
3.1	Intended use	42
3.2	How to prepare the tank before you install the device	42
3.2.1	General information for nozzles.....	43
3.3	Installation recommendations for liquids.....	45
3.3.1	General requirements	45
3.3.2	Installation in standpipes (stilling wells and bypass chambers)	45
4	Electrical connections	47
<hr/>		
4.1	Electrical installation: 2-wire, loop-powered	47
4.1.1	Compact version	47
4.1.2	Remote version	48
4.2	Non-Ex devices	50
4.3	Devices for hazardous locations	52
4.4	Networks	52
4.4.1	General information.....	52
4.4.2	Point-to-point networks	52
4.4.3	Multi-drop networks	53
5	Order information	54
<hr/>		
5.1	Order code	54
6	Notes	61
<hr/>		

1.1 The modular TDR level transmitter for steam boilers

This device is a TDR level transmitter for measuring distance, level, volume and mass of liquids at high temperature and pressure. A ceramic process seal system and patented algorithms, for pressure vessels where the gas composition can change, makes it ideal for level measurement in steam boilers.

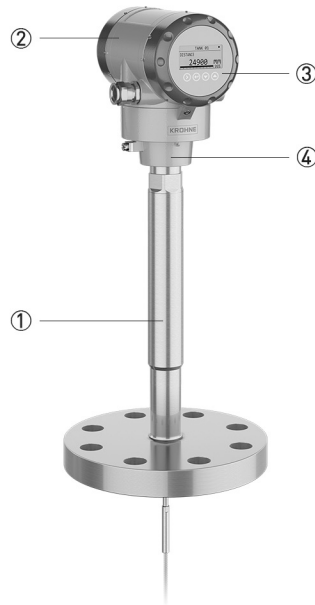

- ① Robust ceramic process seal system for extreme process conditions
- ② Aluminium or stainless steel housing
- ③ Optional LCD screen with 4-button keypad
- ④ Quick coupling system: converter is rotatable and removable under process conditions

The display can be ordered with the device or as an accessory. It shows measurement data on a 128 × 64 pixel screen. The configuration menu permits the device to be set up in a small number of intuitive steps.

Highlights

- Process conditions up to +315°C / +599°F and 320 barg / 4641 psig
- 2-wire 4...20 mA (HART® 7) with optional second output (current or switch/relay)
- Extensive choice of probes for all applications with ±2 mm / 0.08" accuracy
- Measuring distance up to 60 m / 196.85 ft; level and interface measurement
- SIL 2/3-compliant: 1 current output, 2 current outputs, or 1 current output + 1 switch output (relay)
- Quick setup assistant for easy commissioning
- Display keypad directly accessible without opening the cover
- Real-time clock for event logging
- 3-year warranty
- Various converter and electronic versions to facilitate access to the device:
 - Remote converter up to 100 m / 328.08 ft from the probe
 - Sensor extension up to 15 m / 49.21 ft long
 - Horizontal or vertical housing to suit every installation

- Diagnosis functions supply data according to NAMUR NE 107
- PACTware™, HART® DD and DTM provided free of charge with full functionality

Industries

- Chemical & Petrochemical
- Oil & Gas
- Power

Applications

- Level measurement of liquids in industrial boilers (LP)
- Liquid level measurement for various chemical products at high temperature and pressure e.g. ethylene, fertilizer (urea), chlorine, resin, paint, ink, hydrocarbons, LPG, drum, feed water

1.2 Applications

1. Level measurement of liquids

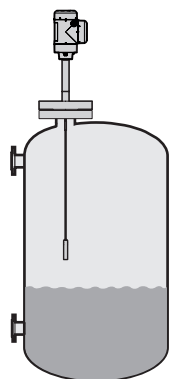

The level transmitter can measure the level of a wide range of liquid products on a large variety of installations within the stated pressure and temperature range. It does not require any calibration: it is only necessary to adapt the probe length and do a short configuration procedure.

2. Volume measurement

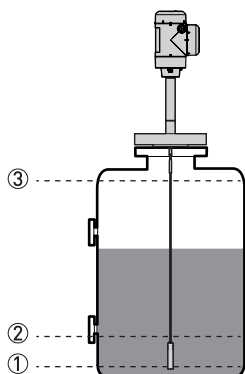

A conversion table (strapping table) function is available in the configuration menu for volume or mass measurement. Up to 30 volume values can be related to level values. For example:
 Level ① = 2 m / Volume ① = e.g. 0.7 m³
 Level ② = 10 m / Volume ② = e.g. 5 m³
 Level ③ = 20 m / Volume ③ = e.g. 17 m³

This data permits the device to calculate volumes between strapping table entries.

1.3 Product family

OPTIFLEX 1100 C

for continuous measurement of liquids and solids up to 16 barg (232 psig) and +100°C (+212°F)



OPTIFLEX 1100 C is a 2-wire TDR level transmitter for measuring distance, level, volume and mass of liquids and solids. Its simple, compact design allows technicians to quickly assemble the probe and attach it to a threaded connection. It is an affordable solution for applications that do not require a high level of accuracy and is also an excellent alternative to traditional level controls such as RF Capacitance, conductive and DP transmitters.

It is ideal for level measurement in buffer tanks, collectors and simple process applications and silo level monitoring in quarrying and agriculture.

OPTIFLEX 3200 C/F

for liquids with hygienic requirements up to 40 barg (580 psig) and +150°C (+302°F)



This TDR level transmitter, with its hygienic design, is ideal for measuring measure level and interface in small vessels and tanks with CIP/SIP cycles. It can also be installed in tanks up to 4 m / 13.12 ft high.

Probe options include:

- a single rod probe made of stainless steel with a surface roughness of $R_a < 0.76 \mu\text{m} / 30 \mu\text{in}$ – AARH, and
- a single rod probe and process connection that are entirely coated with PTFE (TFM-T62, FDA-approved)

OPTIFLEX 6200 C/F

for solids from granulates to powders up to 40 barg (580 psig) and +200°C (392°F)



This level transmitter measures granulates and powders in deep pits or high containers. It has a maximum measuring distance of 40 m / 131.2 ft.

Its durable design can withstand traction loads up to 3500 kg (7700 lb) and electrostatic discharges up to 30 kV. A specially developed set of algorithms also permits the device to accurately measure the level of low-reflective media.

OPTIFLEX 7200 C/F/S/D

for liquids in storage and process applications up to 100 barg (1450 psig) and 250°C (482°F)



The OPTIFLEX 7200 is designed specifically for measuring level and interface in the chemical, oil and gas industries. It can be used in high tanks (max. height 60 m / 197 ft) and pressure vessels.

It has many probe options, making it suitable for a wide range of process conditions. It can also measure volatile products such as carbon disulphide using the reversed interface probe.

The device's software also permits the device to accurately measure the level of products in processes where the composition of the gas above the product can change suddenly. This uses a patented algorithm called "Dynamic Gas-phase Compensation" (DGC).

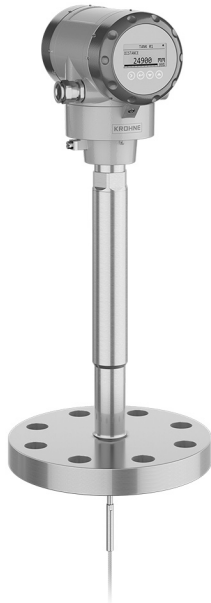
OPTIFLEX 8200 C/F/S**for liquids at high temperature and pressure up to 320 barg (4641 psig) and 315°C (599°F)**

This level transmitter is designed specifically for measuring level and interface in extreme conditions such as boilers in the power, oil and gas industries.

It can be used in very high tanks (max. height 60 m / 197 ft). It can be equipped with a stainless steel housing for corrosive environments.

The device's software also permits the device to accurately measure the level of products in processes where the composition of the gas above the product can change suddenly. This uses a patented algorithm called "Dynamic Gas-phase Compensation" (DGC).

1.4 Application table for probe selection

	Single rod	Single rod (segmented)	Coaxial Ø42 mm / 1.65"	Single cable Ø4 mm / 0.15"
--	------------	------------------------	------------------------	----------------------------

Maximum probe length, L

4 m / 13 ft	■			
6 m / 20 ft		■		
60 m / 197 ft				■

Liquids

Liquid application	■	■	■	■
LPG, LNG	①	①	■	①
Highly viscous liquids	■	■		■
Highly crystallising liquids	■	■		■
Highly corrosive liquids	②		②	②
Foam	■	■	■	■
Agitated liquids	③	③	③	③
Spray in tank	①	①	■	①
Storage tanks	■	■	■	■
Installation in bypass chamber	■	■	■	■
Small diameter nozzles and long nozzles	③	③	■	③
Stilling wells	■	■	■	■

■ standard ■ optional □ on request

- ① Install the device in a stilling well or a bypass chamber
- ② Use a probe made of HASTELLOLOY® C-22®
- ③ Use this probe with an anchor fitting. For more data, refer to the handbook.

1.5 Measuring principle

This Guided Radar (TDR) level meter has been developed from a proven technology called Time Domain Reflectometry (TDR).

The device transmits low-intensity electromagnetic pulses of approximately one nanosecond width along a rigid or flexible conductor. These pulses move at the speed of light. When the pulses reach the surface of the product to be measured, the pulses are reflected with an intensity that depends on the dielectric constant, ϵ_r , of the product (for example, water has a high dielectric constant and reflects the pulse back to the signal converter at 80% of its original intensity).

The device measures the time from when the pulse is emitted to when it is received: half of this time is equivalent to the distance from the reference point of the device (the flange facing) to the surface of the product. The time value is converted into an output current of 4...20 mA and/or a digital signal.

Dust, foam, vapor, agitated surfaces, boiling surfaces, changes in pressure, changes in temperature and changes in density do not have an effect on device performance.

The illustration that follows shows a snapshot of what a user would see on an oscilloscope, if the level of one product is measured.

Level measurement principle (direct mode)

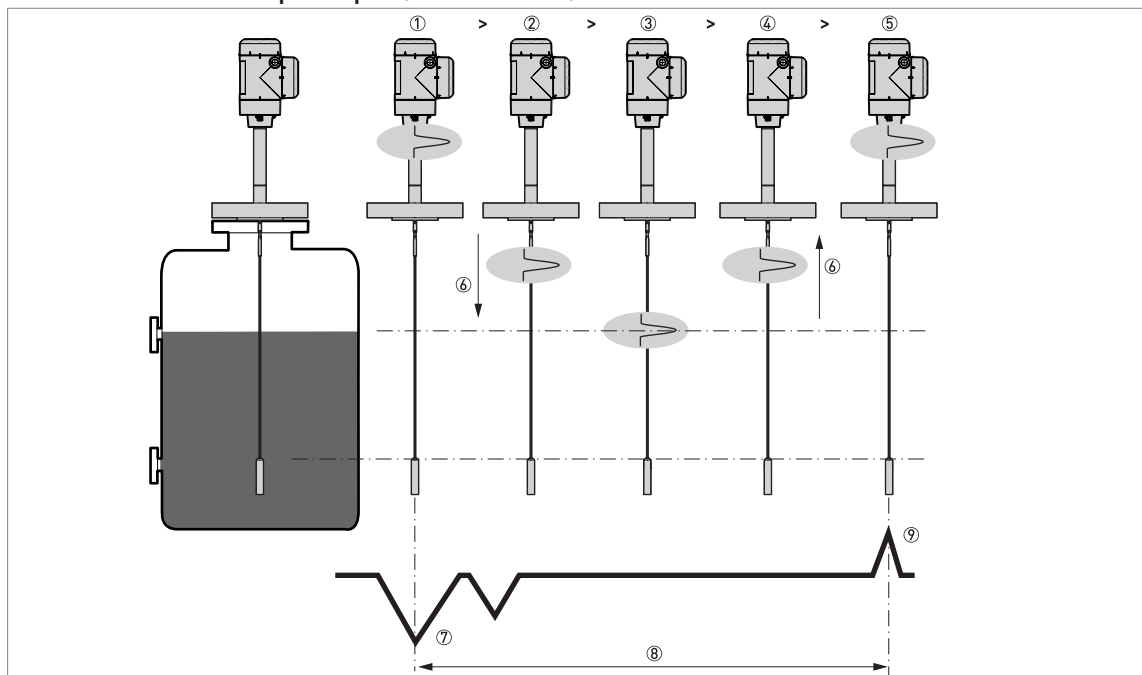

Figure 1-1: Level measurement principle

- ① Time 0: The electromagnetic (EM) pulse is transmitted by the converter
- ② Time 1: The pulse goes down the probe at the speed of light in air, V_1
- ③ Time 2: The pulse is reflected
- ④ Time 3: The pulse goes up the probe at speed, V_1
- ⑤ Time 4: The converter receives the pulse and records the signal
- ⑥ The EM pulse moves at speed, V_1
- ⑦ Transmitted EM pulse
- ⑧ Half of this time is equivalent to the distance from the reference point of the device (the flange facing) to the surface of the product
- ⑨ Received EM pulse

Level and interface measurement principle (direct measurement)

The illustration that follows shows a snapshot of what a user would see on an oscilloscope, if the level and/or interface of products are measured.

The dielectric constant of the top liquid must be less than the dielectric constant of the bottom liquid. If not, or if there is too small a difference, the device may not measure correctly.

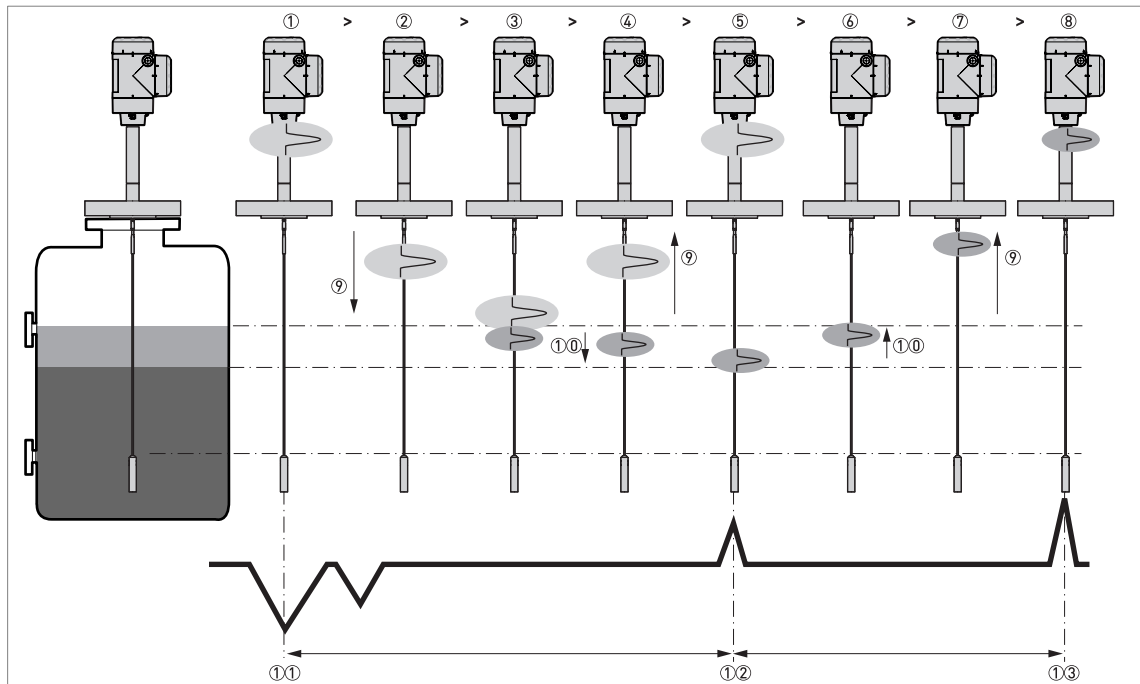

Figure 1-2: Level and interface measurement principle (2 liquids in the tank)

- ① Time 0: The electromagnetic (EM) pulse is transmitted by the converter
- ② Time 1: The pulse goes down the probe at the speed of light in air, V1
- ③ Time 2: Part of the pulse is reflected at the surface of the top liquid, the remaining pulse goes down the probe
- ④ Time 3: Part of the pulse goes up the probe at speed, V1. The remaining pulse goes down the probe at the speed of light in the top product, V2
- ⑤ Time 4: The converter receives part of the pulse and records the signal. The remaining pulse is reflected at the interface of the 2 liquids
- ⑥ Time 5: The remaining pulse goes up the probe at speed, V2
- ⑦ Time 6: The remaining pulse goes up the probe at speed, V1
- ⑧ Time 7: The converter receives the remaining pulse and records the signal
- ⑨ The EM pulse moves at speed, V1
- ⑩ The EM pulse moves at speed, V2
- ⑪ Transmitted EM pulse
- ⑫ Received EM pulse (distance to the top liquid)
- ⑬ Received EM pulse (distance to the interface of 2 liquids)

Level measurement principle (TBF measurement)

If products have a very low dielectric constant ($\epsilon_r < 1.6$), only a small part of the EM pulse is reflected at the surface of the product. Most of the pulse is reflected at the probe end. TBF (tank bottom following) mode is used to measure the distance to the product surface.

TBF mode (indirect measurement) compares:

- The time for the pulse to go to the probe end and go back to the converter when the tank is empty.
- The time for the pulse to go to the probe end and go back to the converter when the tank is full or partially filled.

The level of the product in the tank can be calculated from the time difference.

2.1 Technical data

- *The following data is provided for general applications. If you require data that is more relevant to your specific application, please contact us or your local sales office.*
- *Additional information (certificates, special tools, software,...) and complete product documentation can be downloaded free of charge from the website (Downloadcenter).*

Converter

Measuring system

Application	Level and interface measurement of liquids and pastes
Measuring principle	TDR (time domain reflectometry)
Primary measured value	Distance and interface distance
Secondary values	Level, interface level, volume and mass
Construction	Compact (C) version: Measuring probe attached directly to the signal converter Remote (F) version: Measuring probe installed on a tank and connected by a signal cable (max. length 100 m / 328 ft) to the signal converter Sensor extension (S) version: Measuring probe installed on a tank and connected by a coaxial cable (max. length 15 m / 49 ft) to the signal converter

Operating conditions

Ambient temperature	-40...+80°C / -40...+176°F Integrated LCD display: -20...+60°C / -5...+140°F; if the ambient temperature is not in these limits, the display switches off. The device continues to operate correctly.
Storage temperature	-50...+85°C / -58...+185°F (min. -40°C / -40°F for devices with the integrated LCD display option)
Ingress protection	IEC 60529: IP66 / IP68 (continuous immersion at a depth of 1.5 m for 2 weeks) NEMA 250: NEMA type 4X / 6 (housing) and type 6P (probe)

Materials

Housing	Polyester-coated aluminium or stainless steel (1.4404 / 316L)
Cable entry	Plastic; nickel-plated brass, stainless steel

Electrical connections

Power supply, output 1 (4...20 mA/HART output)	Non-Ex / Ex i: 11.5...30 V DC; min./max. value for an output of 22 mA at the terminals
	Ex d: 13.5...34 V DC; min./max. value for an output of 22 mA at the terminals
Power supply, optional output 2 (4...20 mA output)	Non-Ex / Ex i: 11.5...30 V DC; min./max. value for an output of 22 mA at the terminals (additional power supply needed – output only)
	Ex d: 11.5...34 V DC; min./max. value for an output of 22 mA at the terminals (additional power supply needed – output only)
Power supply, optional input 2 (switch output - relay)	Non-Ex / Ex d: 11.5...34 V DC / 30 mA
	Ex i: 11.5...30 V DC / 30 mA

Current output load	Non-Ex / Ex i: $R_L [\Omega] \leq ((U_{ext} - 11.5 \text{ V})/22 \text{ mA})$. For more data, refer to <i>Minimum power supply voltage</i> on page 20.
	Ex d, output 1: $R_L [\Omega] \leq ((U_{ext} - 13.5 \text{ V})/22 \text{ mA})$. For more data, refer to <i>Minimum power supply voltage</i> on page 20.
	Ex d, output 2: $R_L [\Omega] \leq ((U_{ext} - 11.5 \text{ V})/22 \text{ mA})$. For more data, refer to <i>Minimum power supply voltage</i> on page 20.
Cable entry	M20×1.5; ½ NPT
Cable gland	Standard: none
	Options: M20×1.5, others are available on request
	Cable diameter, output 1: non-Ex / Ex i: 6...7.5 mm / 0.24...0.30"; Ex d: 7...10 mm / 0.28...0.39"; Cable diameter, output 2: non-Ex / Ex i: 6...12 mm / 0.24...0.47"; Ex d: 7...12 mm / 0.28...0.47"
Signal cable – remote version	None for non-Ex devices (4-wire shielded cable of max. length 100 m / 328 ft to be supplied by the customer). Supplied with all Ex-approved devices. For more data, refer to the handbook
Cable entry capacity (terminal)	0.5...2.5 mm ²

Input and output

Measured variable	Time between the emitted and received signal
Current output / HART®	
Output 1 signal	4...20 mA HART® or 3.8...20.5 mA acc. to NAMUR NE 43 ①
Output 2 signal	4...20 mA or 3.8...20.5 mA acc. to NAMUR NE 43
Resolution	±3 µA
Temperature drift (analog)	Typically 50 ppm/K
Temperature drift (digital)	Max. ±15 mm for the full temperature range
Error signal options	High: 22 mA; Low: 3.6 mA acc. to NAMUR NE 43; Hold (frozen value – not available if the output agrees with NAMUR NE 43 or the device is approved for safety-related systems [SIL])
Switch output - relay (option)	
Description	Relay (1 contact, normally open). SIS 2 Sensitive Series (ELESTA GmbH).
Maximum switching capacity	48 V AC / 6 A; 24 V DC / 6 A (according to IEC 60947-5-1)
Voltage range	Category AC-1: 5...48 V AC / Category DC-1: 2...24 V DC
Current range	0.003...6 A
R _{on-state}	< 100 mΩ at 6 V / 100 mA
Switching capacity range	0.04...288 W (VA)

Display and user interface

User interface options	LCD display (128 × 64 pixels in 8-step greyscale with 4-button keypad)
Languages	English, German, French, Italian, Spanish, Portuguese, Japanese, Chinese (simplified), Russian, Czech, Polish and Turkish

Approvals and certification

CE	<p>The device meets the essential requirements of the EU Directives. The manufacturer certifies successful testing of the product by applying the CE marking.</p> <p>For more data about the EU Directives and European Standards related to this device, refer to the EU Declaration of Conformity. You can download this document free of charge from the website (Download Center).</p>
Vibration resistance	<p>Housing: EN 60721-3-4, Category 4M4 (5...8.51 Hz: ±3.5 mm / 8.51...200 Hz: 1g; 15g shock ½sinus: 6 ms) "C" version only: DNVGL-CG-0339, Class A (5...13.2 Hz: ±0.5 mm / 13.2...100 Hz: 0.7g) Refer to "Probe options" in this section for the vibration resistance of probes</p>
Explosion protection	
ATEX (Ex ia, Ex ia/db or Ex ia/tb) EU Type Approval	<p>Compact version</p> <p>II 1/2 G Ex ia IIC T6...T* Ga/Gb; ②</p> <p>II 1/2 D Ex ia IIIC T85°C...T*°C Da/Db ③</p> <p>or...</p> <p>II 1/2 G Ex ia/db IIC T6...T* Ga/Gb; ②</p> <p>II 1/2 D Ex ia/tb IIIC T85°C...T*°C Da/Db ③</p> <p>Remote version, converter</p> <p>II 2 (1) G Ex ia [ia Ga] IIC T6...T4 Gb;</p> <p>II 2 (1) D Ex ia [ia Da] IIIC T85°C...T135°C Db</p> <p>or...</p> <p>II 2 (1) G Ex db ia [ia Ga] IIC T6...T4 Gb;</p> <p>II 2 (1) D Ex ia tb [ia Da] IIIC T80°C...T150°C Db</p> <p>Remote version, sensor</p> <p>II 1/2 G Ex ia IIC T6...T* Ga/Gb; ②</p> <p>II 1/2 D Ex ia IIIC T85°C...T*°C Da/Db ③</p>
ATEX (Ex ic or Ex ic nA) Type Approval	<p>Compact version</p> <p>II 3 G Ex ic IIC T6...T* Gc; ②</p> <p>II 3 D Ex ic IIIC T85°C...T*°C Dc ③</p> <p>or...</p> <p>II 3 G Ex ic nA IIC T6...T* Gc ②</p> <p>Remote version, converter</p> <p>II 3 G Ex ic [ic] IIC T6...T4 Gc;</p> <p>II 3 D Ex ic [ic] IIIC T85°C...T135°C Dc</p> <p>or...</p> <p>II 3 G Ex ic nA [ic] IIC T6...T4 Gc</p> <p>Remote version, sensor</p> <p>II 3 G Ex ic IIC T6...T* Gc; ②</p> <p>II 3 D Ex ic IIIC T85°C...T*°C Dc ③</p>

IECEX	Compact version
	Ex ia IIC T6...T* Ga/Gb; ②
	Ex ia IIIC T85°C...T*°C Da/Db ③
	or...
	Ex ia/db IIC T6...T* Ga/Gb; ②
	Ex ia/tb IIIC T85°C...T*°C Da/Db ③
	or...
	Ex ic IIC T6...T* Gc; ②
	Ex ic IIIC T85°C...T*°C Dc ③
	or...
	Ex ic nA IIC T6...T* Gc ②
	Remote version, converter
	Ex ia [ia Ga] IIC T6...T4 Gb or Ex ic [ic] IIC T6...T4 Gc;
	Ex ia [ia Da] IIIC T85°C...T135°C Db or Ex ic [ic] IIIC T85°C...T135°C Dc;
	or...
	Ex ia [ia Da] IIIC T85°C...T135°C Db or Ex ic [ic] IIIC T85°C...T135°C Dc;
	Ex ia tb [ia Da] IIIC T6...T4 Db
	or...
	Ex ic nA [ic] IIC T6...T4 Gc
	Remote version, sensor
	Ex ia IIC T6...T* Ga/Gb; ②
	Ex ia IIIC T85°C...T*°C Da/Db ③
	or...
	Ex ic IIC T6...T* Gc; ②
	Ex ic IIIC T85°C...T*°C Dc ③

cQPSus – Dual Seal-approved	NEC 500 and CEC Section 18 and Annex J (Division ratings)
	Compact version
	IS, Class I, Div 1, GPS ABCD, T6...T*; ②
	IS, Class II/III, Div 1, GPS EFG, T85°C...T*°C ③
	or...
	XP-IS, Class I, Div 1, GPS A (US only) BCD, T6...T*; ②
	DIP-IS, Class II/III, Div 1, GPS EFG, T85°C...T*°C ③
	or...
	NI, Class I, Div 2, GPS ABCD, T6...T*; ②
	NI, Class II/III, Div 2, GPS FG, T85°C...T*°C ③
	Remote version, converter
	IS, Class I, Div 1, GPS ABCD, T6...T4;
	IS, Class II/III, Div 1, GPS EFG, T85°C...T135°C
	or...
	XP-IS, Class I, Div 1, GPS A (US only) BCD, T6...T4;
	DIP-IS, Class II/III, Div 1, GPS EFG, T85°C...T135°C
	or...
	NI, Class I, Div 2, GPS ABCD, T6...T4;
	NI, Class II/III, Div 2, GPS FG, T85°C...T135°C
	Remote version, sensor
	IS, Class I, Div 1, GPS ABCD, T6...T*; ②
	IS, Class II/III, Div 1, GPS EFG, T85°C...T*°C ③
	or...
	NI, Class I, Div 2, GPS ABCD, T6...T*; ②
NI, Class II/III, Div 2, GPS FG, T85°C...T*°C ③	
NEC 505 and NEC 506 (Zone ratings)	
Compact version	
Class I, Zone 0 AEx ia IIC T6...T* Ga; ②	
Zone 20, AEx ia IIIC T85°C...T*°C Da ③	
or...	
Class I, Zone 1 AEx db ia [ia Ga] IIC T6...T* Gb; ②	
Zone 21, AEx ia tb [ia Da] IIIC T85°C...T*°C Db ③	
Remote version, converter	
Class I, Zone 1 AEx ia [ia Ga] IIC T6...T4 Gb;	
Zone 21, AEx ia [ia Da] IIIC T85°C...T135°C Db	
or...	
Class I, Zone 1 AEx db ia [ia Ga] IIC T6...T4 Gb;	
Zone 21, AEx ia tb [ia Da] IIIC T85°C...T135°C Db	
Remote version, sensor	
Class I, Zone 0 AEx ia IIC T6...T* Ga; ②	
Zone 20, AEx ia IIIC T85°C...T*°C Da ③	

	CEC Section 18 (Zone ratings)
	Compact version
	Ex ia [ia Ga] IIC T6...T* Ga; ②
	Ex ia [ia Da] IIIC T85°C...T*°C Da ③
	or...
	Ex db ia [ia Ga] IIC T6...T* Gb; ②
	Ex ia tb [ia Da] IIIC T85°C...T*°C Db ③
	Remote version, converter
	Ex ia [ia Ga] IIC T6...T4 Gb;
	Ex ia [ia Da] IIIC T85°C...T135°C Db
	or...
	Ex db ia [ia Ga] IIC T6...T4 Gb;
	Ex ia tb [ia Da] IIIC T85°C...T135°C Db
	Remote version, sensor
	Ex ia [ia Ga] IIC T6...T* Ga; ②
	Ex ia [ia Da] IIIC T85°C...T*°C Da ③
NEPSI	Compact version
	Ex ia IIC T*~T6 Ga/Gb; ②
	Ex iaD 20/21 T85~T** ③
	or...
	Ex ia/d IIC T*~T6 Ga/Gb; ②
	Ex iaD 20 tD A21 IP6X T85°C~T*°C ③
	Remote version, converter
	Ex ia [ia Ga] IIC T4~T6 Gb;
	Ex iaD [iaD 20] 21 T85~T135
	or...
	Ex d ia [ia Ga] IIC T4~T6 Gb;
	Ex iaD 21 tD A21 [iaD 20] IP6X T85°C~T135°C
	Remote version, sensor
	Ex ia IIC T*~T6 Ga/Gb; ②
	Ex iaD 20/21 T85~T* ③

EAC-EX (pending)	Compact version
	Ga/Gb Ex ia IIC T6...T* X; ②
	Da/Db Ex ia IIIC T85°C...T*°C X ③
	or...
	Ga/Gb Ex ia/db IIC T6...T* X; ②
	Da/Db Ex ia/tb IIIC T85°C...T*°C X ③
	Remote version, converter
	1Ex ia [ia Ga] IIC T6...T4 Gb X;
	Ex ia [ia Da] IIIC T85...T135 Db X
	or...
	1Ex db ia [ia Ga] IIC T6...T4 Gb X;
	Ex ia tb [ia Da] IIIC T85°C...T135°C Db X
	Remote version, sensor
	Ga/Gb Ex ia IIC T6...T* X; ②
Da/Db Ex ia IIIC T85°C...T*°C X ③	
Other standards and approvals	
SIL	C (Compact) and S (Sensor Extension) versions only: SIL 2/3 (SIL3: 1oo2 architecture is necessary for homogeneous redundancy) – certified according to all the requirements in EN 61508 (Full Assessment) and for high/low continuous demand mode operation. HFT=0, SFF=93% (for non-Ex / Ex i devices with one output), 94% (for non-Ex / Ex i devices with two outputs) or 95% (for Ex d devices), type B device
EMC	Electromagnetic Compatibility (EMC) directive. The device agrees with this directive and its related standard if the device has a single probe that is installed in a metallic tank. SIL 2-approved devices agree with EN 61326-3-1 and EN 61326-3-2.
NAMUR	NAMUR NE 21 Electromagnetic Compatibility (EMC) of Industrial Process and Laboratory Control Equipment
	NAMUR NE 43 Standardization of the Signal Level for the Failure Information of Digital Transmitters
	NAMUR NE 53 Software and Hardware of Field Devices and Signal Processing Devices with Digital Electronics
	NAMUR NE 107 Self-Monitoring and Diagnosis of Field Devices
Conformity to construction codes	On request (for equipment used in the oil and gas industries): NACE MR0175 (ISO 15156); NACE MR0103 (ISO 17945)

① HART® is a registered trademark of the FieldComm Group™

② If the device has a ceramic process seal system and a Kalrez® gasket, then T* = T1. For all other versions, T* = T3.

③ If the device has a ceramic process seal system and a Kalrez® gasket, then T*°C = T315°C or T** = 315. If the device has a ceramic process seal system and a FPM/FKM gasket, then T*°C = T200°C or T** = T200. For all other versions, T*°C = T150°C or T** = T150.

Probe options

	Single rod Ø8 mm / 0.32"		Single cable Ø4 mm / 0.16"	Coaxial Ø42 mm / 1.65"
	Single-piece	Segmented		

Measuring system

Application	Liquids			
Measuring range	0.6...4 m / 3.28...13.12 ft	0.6...6 m / 3.28...19.69 ft	1...60 m / 3.28...196.85 ft	0.6...6 m / 3.28...19.69 ft
Dead zone	This depends on the type of probe. For more data, refer to <i>Measurement limits</i> on page 24.			

Measuring accuracy

Accuracy (in direct mode)	Standard ± 2 mm / ± 0.08 ", when distance ≤ 10 m / 33 ft; $\pm 0.02\%$ of measured distance, when distance > 10 m / 33 ft Interface ± 5 mm / ± 0.2 ", when distance ≤ 10 m / 33 ft; $\pm 0.05\%$ of measured distance, when distance > 10 m / 33 ft
Accuracy (in TBF mode)	± 20 mm / ± 0.8 "
Minimum layer (interface)	50 mm / 2"
Resolution	0.1 mm / 0.004"
Repeatability	± 1 mm / ± 0.04 "
Maximum rate of change at 4 mA	100 m/min / 328 ft/min
Reference conditions acc. to EN 61298-1	
Temperature	+15...+25°C / +59...+77°F
Pressure	1013 mbara ± 50 mbar / 14.69 psia ± 0.73 psi
Relative air humidity	60% $\pm 15\%$

Operating conditions

Min./Max. temperature at the process connection ①	-50...+315°C / -58...+599°F	
Pressure	-1...320 barg / -14.5...4641 psig	
Viscosity (liquids only)	10000 mPa·s / 10000 cP	2000 mPa·s / 2000 cP
Dielectric constant	≥ 1.6	≥ 1.3
	Interface: $\epsilon_r(\text{interface}) \gg \epsilon_r(\text{level})^2$	
	TBF mode: ≥ 1.1	
Vibration resistance	EN 60721-3-4, Category 4M3 (5...8.22 Hz: ± 0.75 mm / 8.22...200 Hz: 0.2g; 5g shock $\frac{1}{2}$ sinus: 6 ms) DNVGL-CG-0339, Class A (5...13.2 Hz: ± 0.5 mm / 13.2...100 Hz: 0.7g)	EN 60721-3-4, Category 4M4 (5...8.51 Hz: ± 3.5 mm / 8.51...200 Hz: 1g; 15g shock $\frac{1}{2}$ sinus: 6 ms) DNVGL-CG-0339, Class A (5...13.2 Hz: ± 0.5 mm / 13.2...100 Hz: 0.7g)

	Single rod Ø8 mm / 0.32"		Single cable Ø4 mm / 0.16"	Coaxial Ø42 mm / 1.65"
	Single-piece	Segmented		

Materials

Probe	Stainless steel (1.4404 / 316L); HASTELLOY® C-22® (2.4602) ②	Stainless steel (1.4404 / 316L)	Stainless steel (1.4401 / 316); HASTELLOY® C-22® (2.4602) ②	Stainless steel (1.4404 / 316L) ③
Spacer	—	—	—	PEEK
Gasket (process seal)	FKM/FPM, Kalrez® 7075, EPDM For more data, refer to the "Process seal technical data" table in this section. ④			
Process connection	Stainless steel (1.4404 / 316L); HASTELLOY® C-22® (2.4602) ②			

Process connections

Thread	For more data on options, refer to <i>Order code</i> on page 54
Flange	For more data on options, refer to <i>Order code</i> on page 54

① Also depends on the temperature limits of the gasket material. Refer to "Materials" in this table and the "Process seal technical data" table.

② HASTELLOY® is a registered trademark of Haynes International, Inc.

③ HASTELLOY® C-22® (2.4602) is available on request

④ Kalrez® is a registered trademark of DuPont Performance Elastomers L.L.C.

Process seal technical data

Sealing system	Process seal material	Process pressure range		Process connection temperature range	
		[barg]	[psig]	[°C]	[°F]
Single (Ceramic)D ouble (Ceramic) ①	FKM/FPM	-1...320	-14.5...4641	-40...+200	-40...+392
	Kalrez® 7075			-20...+315	-4...+599
	EPDM			-50...+150	-58...+302

① This includes a temperature extension

Process connection options: flange facing finish

Type (flange facing)	Flange facing finish, R _a (min...max)	
	[µm]	[µin – AARH]

EN 1092-1

B1 or E	3.2...12.5	125...500
---------	------------	-----------

ASME B16.5

RF or FF	3.2...6.3	125...250
RJ	≤ 1.6	≤ 63

JIS B2220

RF	3.2...6.3	125...250
----	-----------	-----------

2.2 Minimum power supply voltage

Use these graphs to find the minimum power supply voltage for a given current output load.

Non-Ex and Hazardous Location approved (Ex i / IS / NI) devices

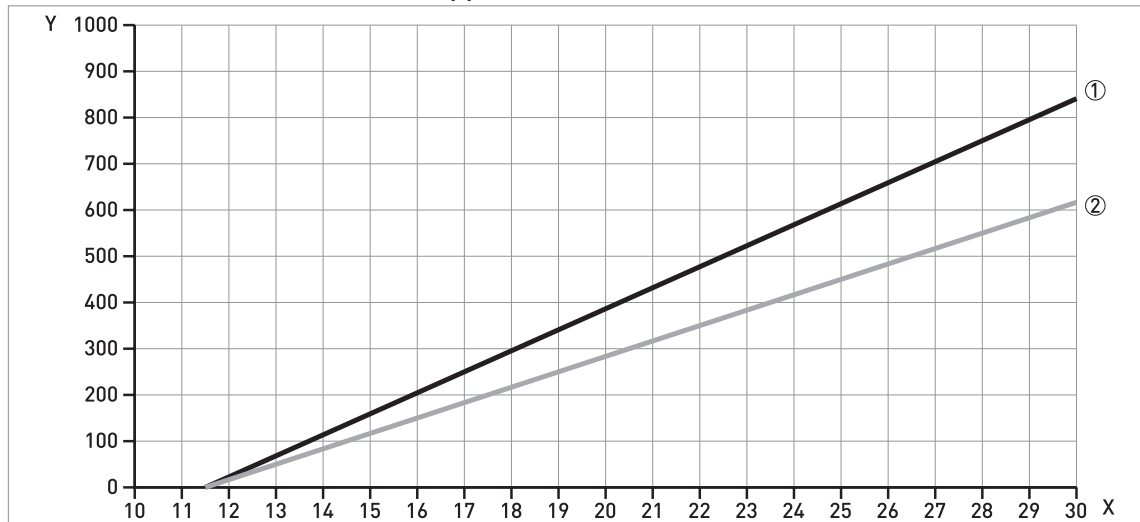

Figure 2-1: Non-Ex and Hazardous Location approval (Ex i / IS / NI): minimum power supply voltage for an output of 22 mA (switch output - relay option: 30 mA) at the terminals

X: Power supply U [V DC]

Y: Current output load R_L [Ω]

① Output 1: 4...20 mA/HART

Output 2: 4...20 mA (NOTE: use a separate power supply to energize output 2)

② Input 2: switch output - relay option

Hazardous Location (Ex d / XP/ DIP) approved devices

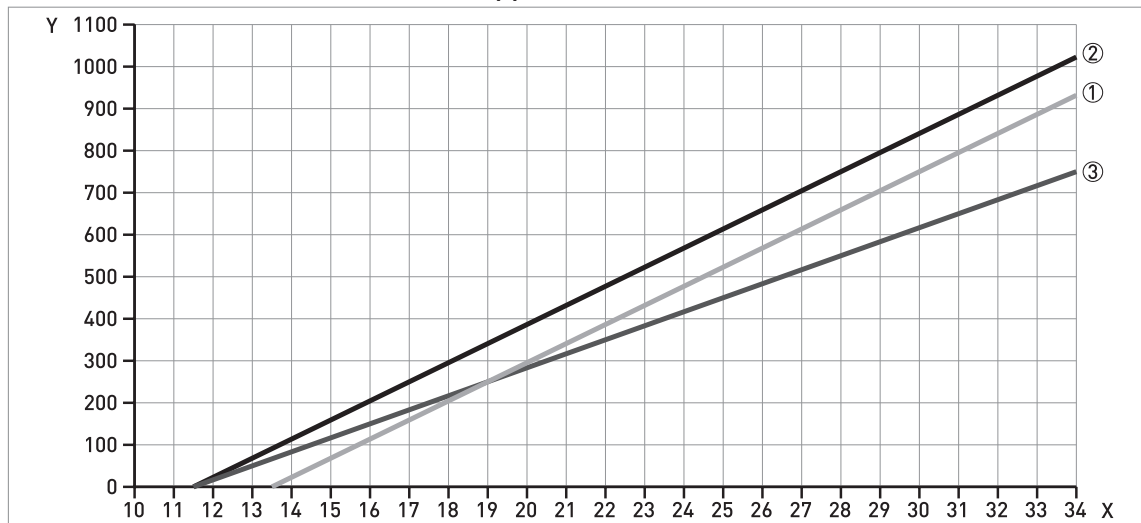

Figure 2-2: Non-Ex and Hazardous Location approval (Ex d / XP/ DIP): minimum power supply voltage for an output of 22 mA (switch output - relay option: 30 mA) at the terminals

X: Power supply U [V DC]

Y: Current output load R_L [Ω]

① Output 1: 4...20 mA/HART

② Output 2: 4...20 mA (NOTE: use a separate power supply to energize output 2)

③ Input 2: switch output - relay option

2.3 Process pressure and process connection temperature limits

Make sure that the transmitters are used within their operating limits. Obey the temperature limits of the process seal and the flange.

The process connection temperature range must agree with the temperature limits of the gasket material. Limits of the gasket material are shown below each graph. For more data about pressure and temperature limits of process connections, refer to the related standards (EN 1092-1, ASME B16.5 etc.).

Pressure and temperature limits (PN10...100 / Class 150...600)

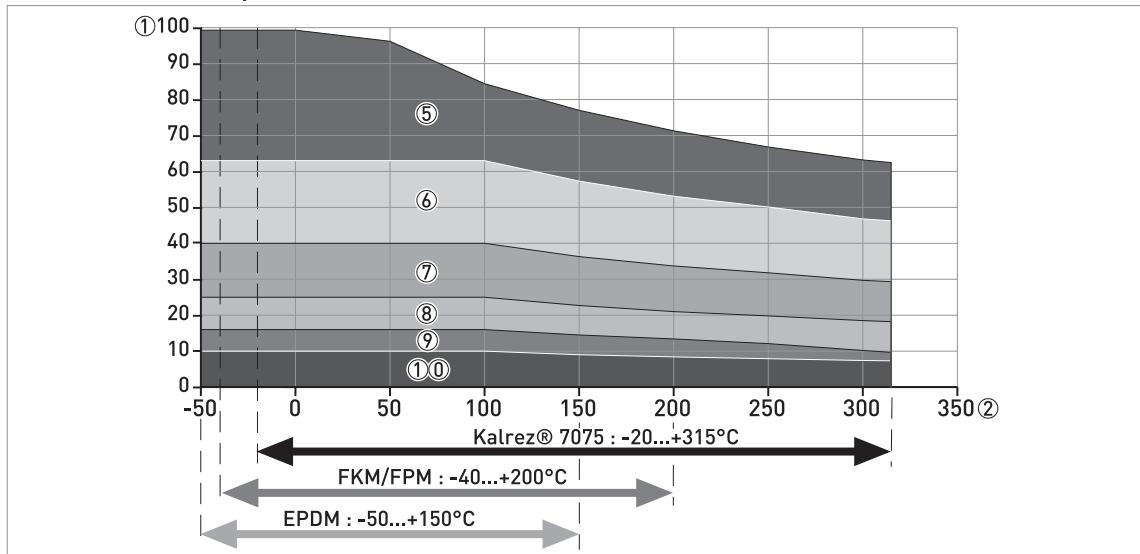

Figure 2-3: Operating limits (PN10...100 / Class 150...600): graph of process pressure (barg) against process connection temperature [°C]

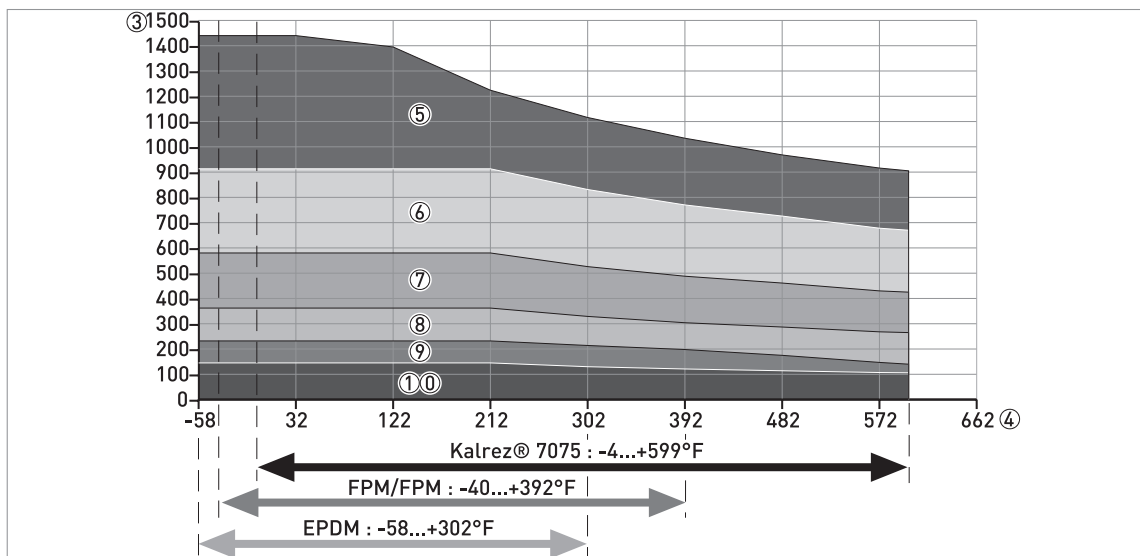

Figure 2-4: Operating limits (PN10...100 / Class 150...600): graph of process pressure (psig) against process connection temperature [°F]

- ① Process pressure, P_s [barg]
- ② Process connection temperature, T [°C]
- ③ Process pressure, P_s [psig]
- ④ Process connection temperature, T [°F]
- ⑤ Flange connection, PN100 (EN 1092-1) or Class 600 (ASME B16.5)
- ⑥ Flange connection, PN63 (EN 1092-1)
- ⑦ Flange connection, PN40 (EN 1092-1) or Class 300 (ASME B16.5)
- ⑧ Flange connection, PN25 (EN 1092-1)
- ⑨ Flange connection, PN16 (EN 1092-1) or Class 150 (ASME B16.5)
- ⑩ Flange connection, PN10 (EN 1092-1)

Pressure and temperature limits (PN160...400 / Class 900...2500)

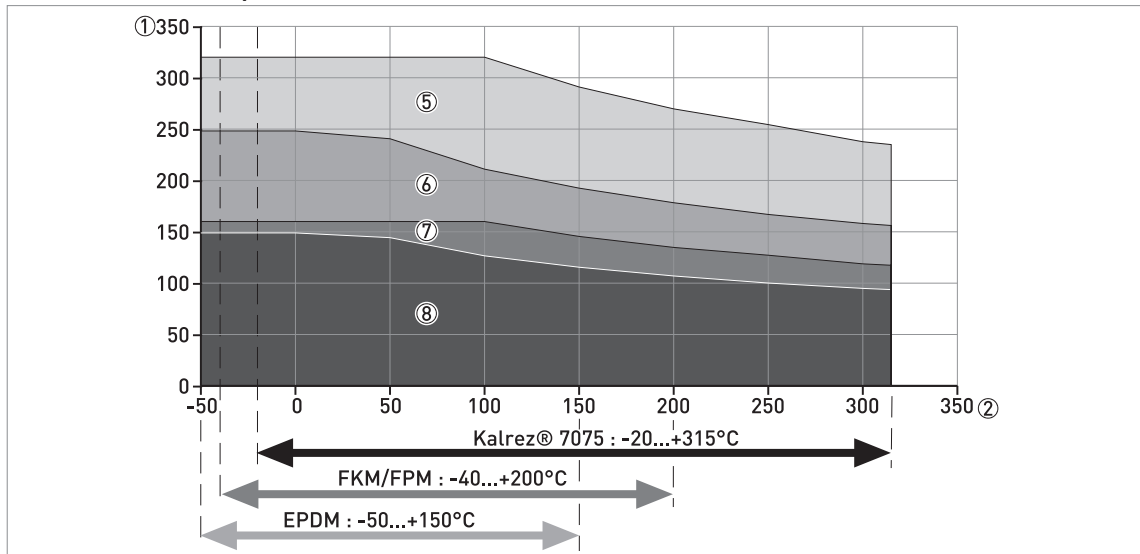

Figure 2-5: Operating limits (PN160...400 / Class 900...2500): graph of process pressure (barg) against process connection temperature [°C]

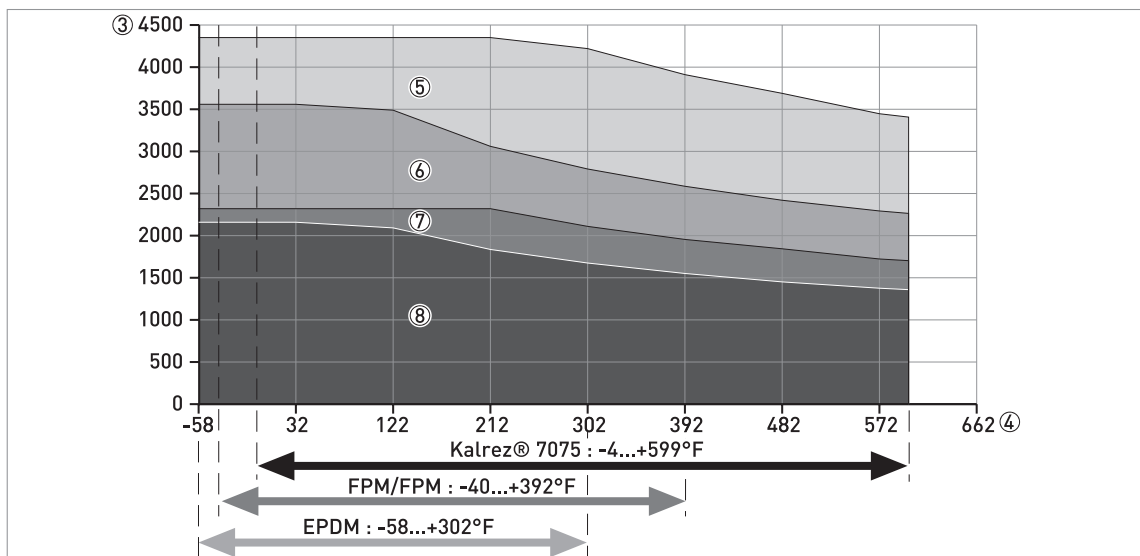

Figure 2-6: Operating limits for devices (PN160...400 / Class 900...2500): graph of process pressure (psig) against process connection temperature [°F]

- ① Process pressure, P_s [barg]
- ② Process connection temperature, T [°C]
- ③ Process pressure, P_s [psig]
- ④ Process connection temperature, T [°F]
- ⑤ Flange connection, PN320 (EN 1092-1), PN400 (EN 1092-1) or Class 2500 (ASME B16.5)
- ⑥ Flange connection, PN250 (EN 1092-1) or Class 1500 (ASME B16.5)
- ⑦ Flange connection, PN160 (EN 1092-1)
- ⑧ Flange connection, Class 900 (ASME B16.5)

2.4 Measurement limits

Single cable and single rod probes

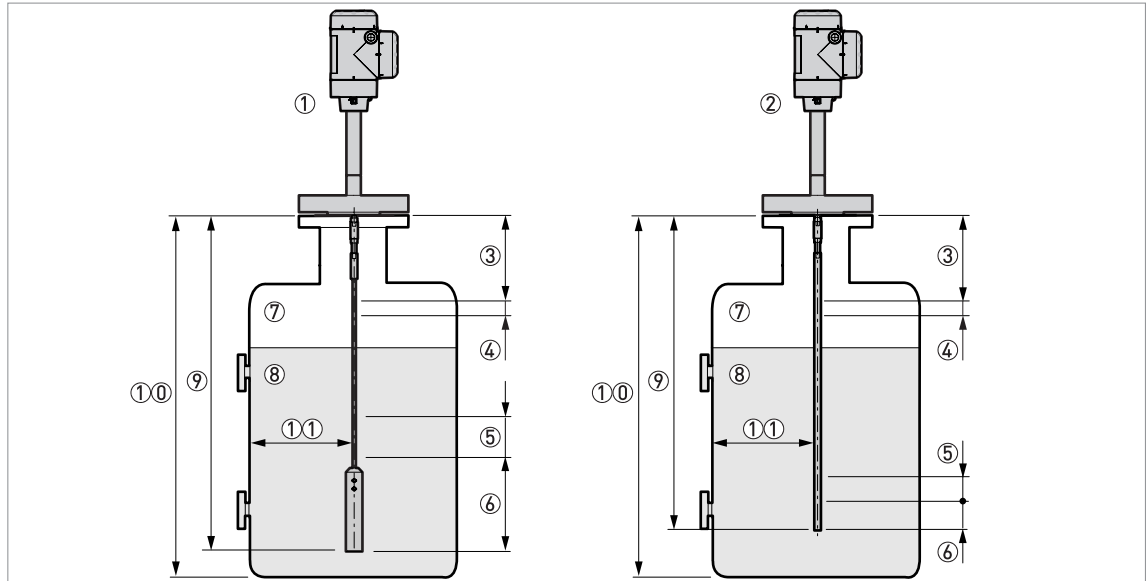

Figure 2-7: Measurement limits: single cable and single rod probes

- ① Device with a single cable probe
- ② Device with a single rod probe
- ③ **Top dead zone:** Top part of the probe where measurement is not possible
- ④ **Top non-linearity zone:** Top part of the probe with a lower accuracy of $\pm 30 \text{ mm} / \pm 1.18''$
- ⑤ **Bottom non-linearity zone:** Bottom part of the probe with a lower accuracy of $\pm 30 \text{ mm} / \pm 1.18''$
- ⑥ **Bottom dead zone:** Bottom part of the probe where measurement is not possible
- ⑦ **Gas (Air)**
- ⑧ **Product**
- ⑨ **L, Probe length**
- ⑩ **Tank Height**
- ⑪ **Minimum distance from the probe to a metallic tank wall:** Single cable or single rod probes = $300 \text{ mm} / 12''$

Measurement limits (dead zone) in mm and inches

Probe	$\epsilon_r = 80$				$\epsilon_r = 2.5$			
	Top ③		Bottom ⑥		Top ③		Bottom ⑥	
	[mm]	[inches]	[mm]	[inches]	[mm]	[inches]	[mm]	[inches]
4 mm / 0.16" single cable ①	70	2.76	120	4.72	70	2.76	200	7.87
Single rod	70	2.76	20	0.79	70	2.76	60	2.36

① If the cable probe does not have a counterweight, speak or write to your local supplier for more data

Measurement limits (non-linearity zone) in mm and inches

Probes	$\epsilon_r = 80$				$\epsilon_r = 2.5$			
	Top ④		Bottom ⑤		Top ④		Bottom ⑤	
	[mm]	[inches]	[mm]	[inches]	[mm]	[inches]	[mm]	[inches]
Ø4 mm / 0.16" single cable ①	150	5.91	0	0	150	5.91	0	0
Single rod	150	5.91	0	0	150	5.91	0	0

① If the cable probe does not have a counterweight, speak or write to your local supplier for more data

80 is ϵ_r of water; 2.5 is ϵ_r of oil

If you did the Auto Setup procedure after you installed the device, the values in the tables are correct. If you did not do the Auto Setup procedure, then the values for the dead zones and the non-linearity zones increase. If the cable probe does not have a counterweight, speak or write to your local supplier for more data.

The device software function "Blocking Distance" is set at the factory to 200 mm / 7.87", which is higher than or equal to the largest dead zone. This value agrees with the minimum dielectric constant at which the device can measure the level of a product. You can adjust "Blocking Distance" to agree with the dead zone (for this data, refer to the measurement limits table). For more data about the device software, refer to the handbook.

Coaxial probe

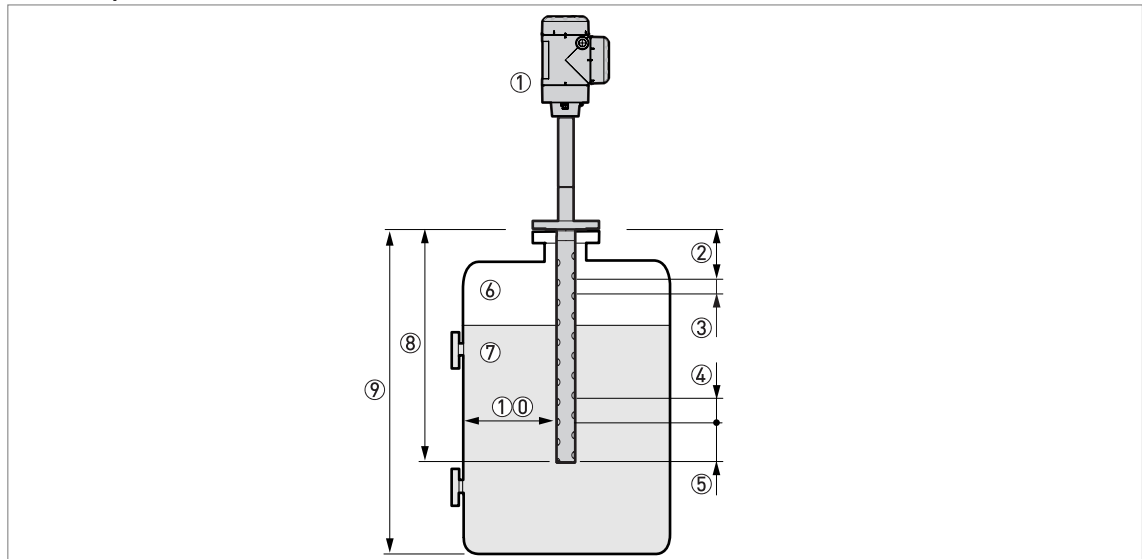

Figure 2-8: Measurement limits: coaxial probe

- ① Device with a coaxial probe
- ② **Top dead zone:** Top part of the probe where measurement is not possible
- ③ **Top non-linearity zone:** Top part of the probe with a lower accuracy of $\pm 30 \text{ mm} / \pm 1.18''$
- ④ **Bottom non-linearity zone:** Bottom part of the probe with a lower accuracy of $\pm 30 \text{ mm} / \pm 1.18''$
- ⑤ **Bottom dead zone:** Bottom part of the probe where measurement is not possible
- ⑥ **Gas (Air)**
- ⑦ **Product**
- ⑧ **L, Probe length**
- ⑨ **Tank Height**
- ⑩ **Minimum distance from the probe to a metallic tank wall:** Coaxial probe = $0 \text{ mm} / 0''$

Measurement limits (dead zone) in mm and inches

Probe	$\epsilon_r = 80$				$\epsilon_r = 2.5$			
	Top ②		Bottom ⑤		Top ②		Bottom ⑤	
	[mm]	[inches]	[mm]	[inches]	[mm]	[inches]	[mm]	[inches]
Coaxial	50	1.97	20	0.79	50	1.97	20	0.79

Measurement limits (non-linearity zone) in mm and inches

Probe	$\epsilon_r = 80$				$\epsilon_r = 2.5$			
	Top ③		Bottom ④		Top ③		Bottom ④	
	[mm]	[inches]	[mm]	[inches]	[mm]	[inches]	[mm]	[inches]
Coaxial	80	3.15	0	0	80	3.15	0	0

80 is ϵ_r of water; 2.5 is ϵ_r of oil

If you did the Auto Setup procedure after you installed the device, the values in the tables are correct. If you did not do the Auto Setup procedure, then the values for the dead zones and the non-linearity zones increase.

The device software function "Blocking Distance" is set at the factory to 50 mm / 1.97", which is higher than or equal to the largest dead zone. This value agrees with the minimum dielectric constant at which the device can measure the level of a product. You can adjust "Blocking Distance" to agree with the dead zone (for this data, refer to the measurement limits table). For more data about the device software, refer to the handbook.

2.5 Dimensions and weights

2.5.1 General notes

All housing covers have bayonet connectors unless it is an explosion-proof (XP / Ex d-approved) device or has the second current output / switch output (relay) option. If the device has the second current output / switch output (relay) option or has an Ex d / XP (explosion-proof) approval, the terminal compartment cover has a thread with a flame path.

2.5.2 Primary components

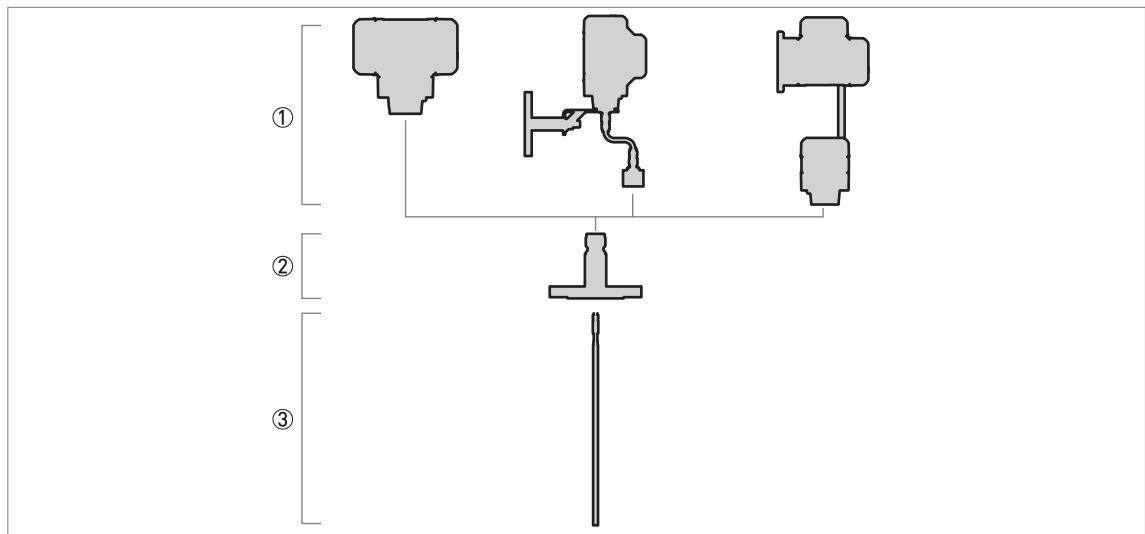

Figure 2-9: Primary components

- ① Signal converter. From left to right:
 - Vertical / Horizontal compact version (C)
 - Vertical / Horizontal compact version with sensor extension (S) – signal converter attached to the process connection with a coaxial cable
 - Remote version (F) – signal converter attached to the probe electronics in a different housing with an RS-485 cable
- ② Process connection: threaded or flange connection, including the process seal option. For more data, refer to *Technical data* on page 11.
- ③ Probe

2.5.3 Signal converter and probe electronics options

Compact version (C)

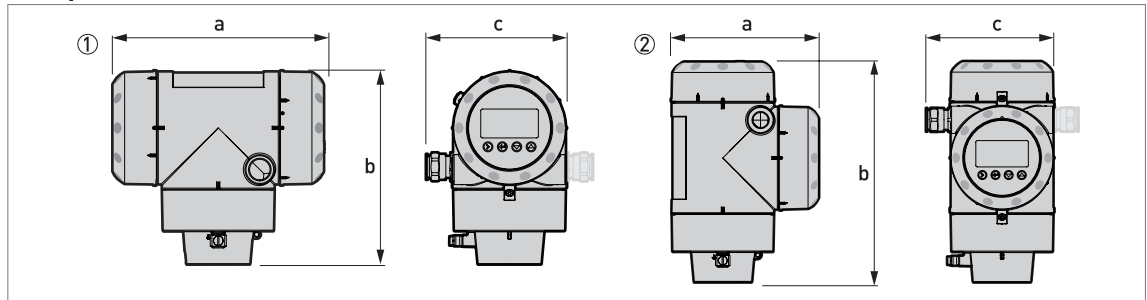

Figure 2-10: Compact version (C)

- ① Horizontal compact version
- ② Vertical compact version

If the device has the second current output / switch output (relay) option, use the dimensions given for Ex d / XP-approved devices.

Dimensions [mm]	Horizontal		Vertical	
	Non-Ex / Ex i / IS	Optional output / Ex d / XP	Non-Ex / Ex i / IS	Optional output / Ex d / XP
a	191	258	147	210
b	175	175	218	218
c	127	127 (153) ①	127	127 (153) ①

① Use the dimension in round brackets if the device has 2 current outputs or a switch output (relay)

Dimensions [inches]	Horizontal		Vertical	
	Non-Ex / Ex i / IS	Optional output / Ex d / XP	Non-Ex / Ex i / IS	Optional output / Ex d / XP
a	7.52	10.16	5.79	8.27
b	6.89	6.89	8.23	8.23
c	5.00	5.00 (6.02) ①	5.00	5.00 (6.02) ①

① Use the dimension in round brackets if the device has 2 current outputs or a switch output (relay)

Sensor extension with vertical compact version (S)

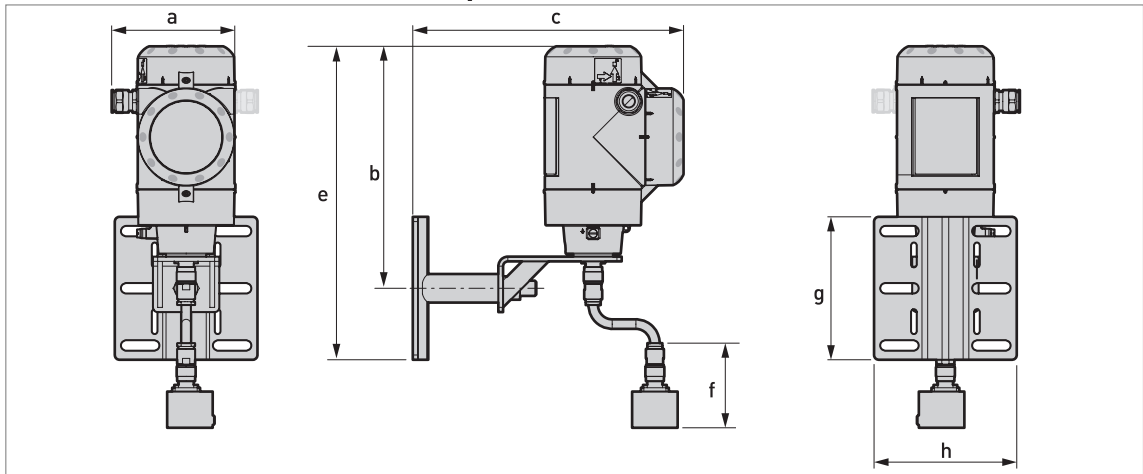

Figure 2-11: Sensor extension with vertical compact version (S)

If the device has the second current output / switch output (relay) option, use the dimensions given for Ex d / XP-approved devices.

	Dimensions [mm]						
	a	b	c	e	f	g	h
Non-Ex / Ex i / IS	127	254	285.4	329	89	150	150.4
Optional output / Ex d / XP	127 (153) ①	254	348.4	329	89	150	150.4

① Use the dimension in round brackets if the device has 2 current outputs or a switch output (relay)

	Dimensions [inches]						
	a	b	c	e	f	g	h
Non-Ex / Ex i / IS	5.00	10.00	11.23	12.95	3.50	5.91	5.92
Optional output / Ex d / XP	5.00 (6.02) ①	10.00	13.72	12.95	3.50	5.91	5.92

① Use the dimension in round brackets if the device has 2 current outputs or a switch output (relay)

Sensor extension with horizontal compact version (S)

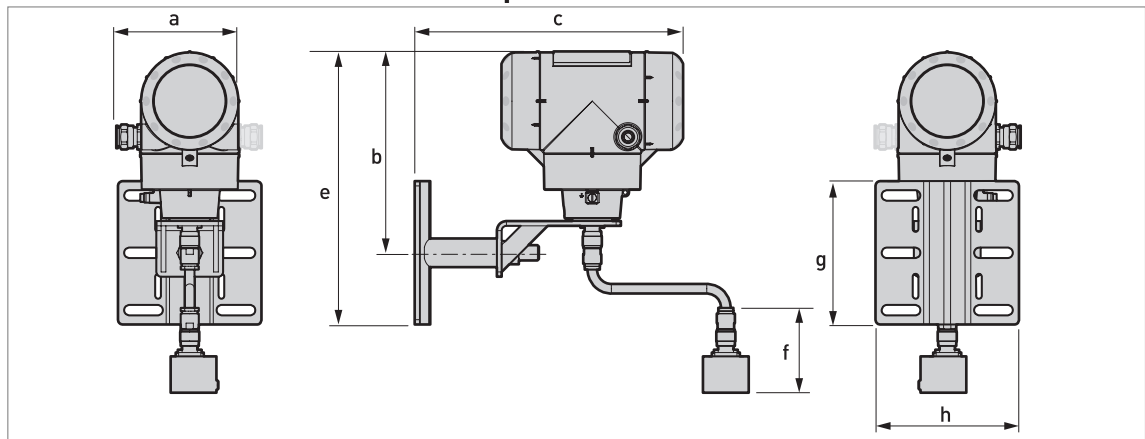

Figure 2-12: Sensor extension with horizontal compact version (S)

If the device has the second current output / switch output (relay) option, use the dimensions given for Ex d / XP-approved devices.

	Dimensions [mm]						
	a	b	c	e	f	g	h
Non-Ex / Ex i / IS	127	211	281	285	89	150	150.4
Optional output / Ex d / XP	127 (153) ①	211	344	285	89	150	150.4

① Use the dimension in round brackets if the device has 2 current outputs or a switch output (relay)

	Dimensions [inches]						
	a	b	c	e	f	g	h
Non-Ex / Ex i / IS	5.00	8.31	11.06	11.22	3.50	5.91	5.92
Optional output / Ex d / XP	5.00 (6.02) ①	8.31	13.54	11.22	3.50	5.91	5.92

① Use the dimension in round brackets if the device has 2 current outputs or a switch output (relay)

**Sensor extension with compact version (S)
– wall bracket**

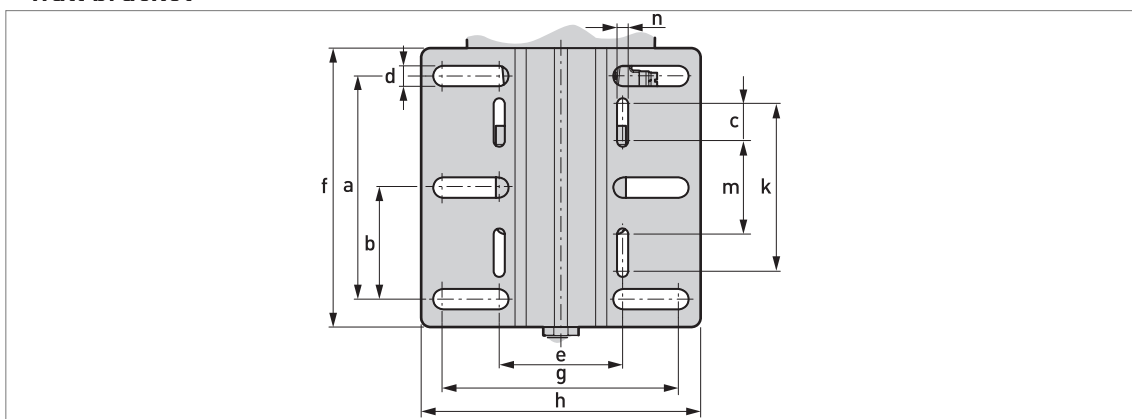

Figure 2-13: Wall bracket

	Dimensions [mm]					
	a	b	c	d	e	f
Wall bracket	120	60	20	11	67.4	150

	Dimensions [mm]					
	g	h	k	m	n	
Wall bracket	126.4	150.4	90	50	6	

	Dimensions [inches]					
	a	b	c	d	e	f
Wall bracket	4.72	2.36	0.79	0.43	2.65	5.91

	Dimensions [inches]					
	g	h	k	m	n	
Wall bracket	4.98	5.92	3.54	1.97	0.24	

Remote version (F) – remote converter housing

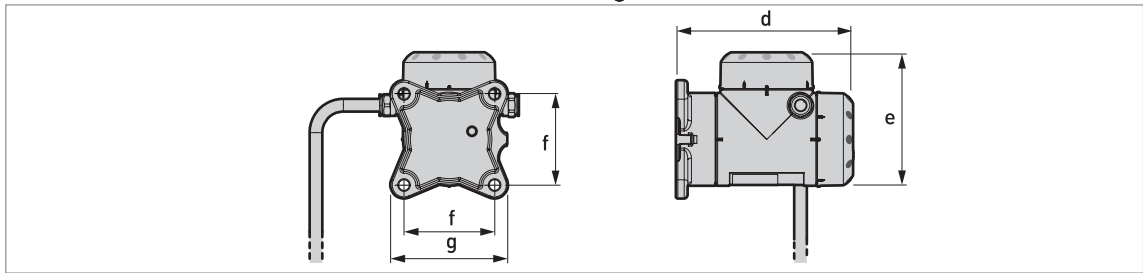

Figure 2-14: Remote version (F) – remote converter housing

If the device has the second current output / switch output (relay) option, use the dimensions given for Ex d / XP-approved devices.

Dimensions [mm]	Remote	
	Non-Ex / Ex i / IS	Optional output / Ex d / XP
d	195	195
e	146	209
f	100	100
g	130	130

Dimensions [inches]	Remote	
	Non-Ex / Ex i / IS	Optional output / Ex d / XP
d	7.68	7.68
e	5.75	8.23
f	3.94	3.94
g	5.12	5.12

Remote version (F) – probe electronics housing

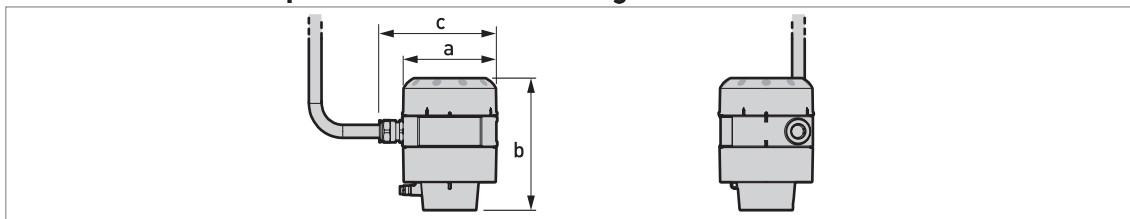

Figure 2-15: Remote version (F) – probe electronics housing

Dimensions [mm]	Remote	
	Non-Ex / Ex i / IS	Ex d / XP
a	104	104
b	142	142
c	129	129

Dimensions [inches]	Remote	
	Non-Ex / Ex i / IS	Ex d / XP
a	4.09	4.09
b	5.59	5.59
c	5.08	5.08

Converter and probe electronics housing weights

Type of housing	Weights			
	Aluminium housing		Stainless steel housing	
	[kg]	[lb]	[kg]	[lb]
Compact converter	2.8	6.2	6.4	14.1
Remote converter ①	2.5	5.5	5.9	13.0
Probe electronics housing ①	1.8	4.0	3.9	8.6

One output / Non-Ex / intrinsically-safe (Ex i / IS)

Compact converter	2.8	6.2	6.4	14.1
Remote converter ①	2.5	5.5	5.9	13.0
Probe electronics housing ①	1.8	4.0	3.9	8.6

Optional output / Explosion proof (Ex d / XP)

Compact converter	3.2	7.1	7.5	16.5
Remote converter ①	2.9	6.40	7.1	15.65
Probe electronics housing ①	1.8	4.0	3.9	8.6

① The remote version of the device has a "remote converter" and a "probe electronics housing". For more data, refer to "Housing dimensions" at the start of this section.

2.5.4 Process connection options

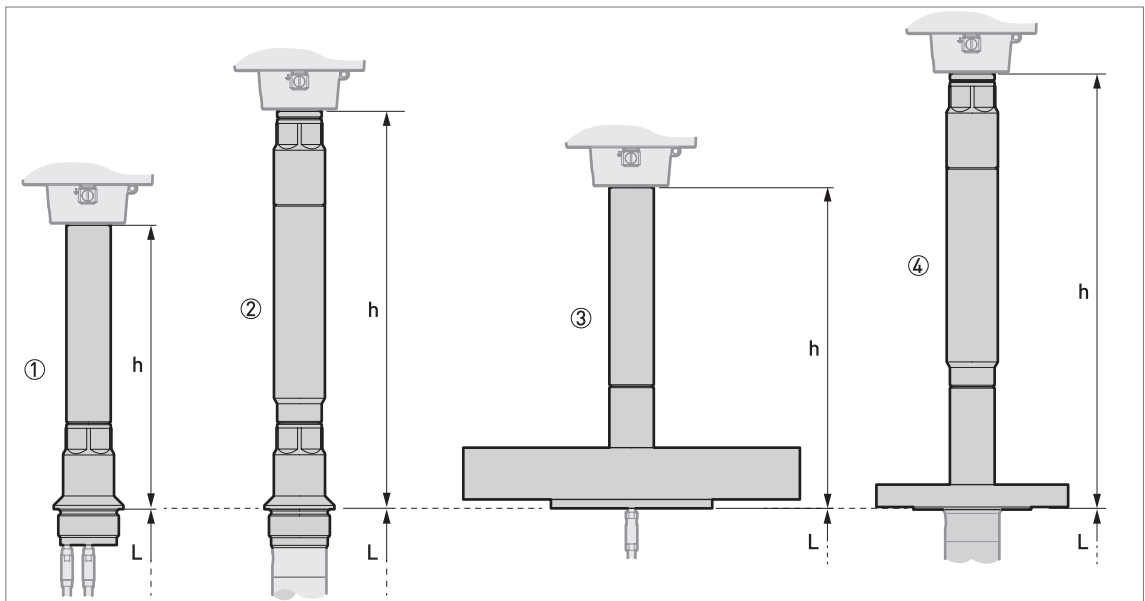

Figure 2-16: Process connection options

h = height of process connection

L = probe length

- ① Threaded connection with single ceramic process seal system
- ② Threaded connection with double ceramic process seal system
- ③ Flange with single ceramic process seal system
- ④ Flange with double ceramic process seal system

Process connection	Process seal system	Dimensions [mm]	
		h	L
Threaded connection	Single Ceramic	223.7	①
	Double ceramic	311.9	
Flange	Single Ceramic	252	①
	Double ceramic	340.2	

① Refer to "Probe options" in this chapter

Process connection	Process seal system	Dimensions [inches]	
		h	L
Threaded connection	Single Ceramic	8.10	①
	Double ceramic	12.28	
Flange	Single Ceramic	9.92	①
	Double ceramic	13.39	

① Refer to "Probe options" in this chapter

2.5.5 Probe options

Single probes: options and overall dimensions

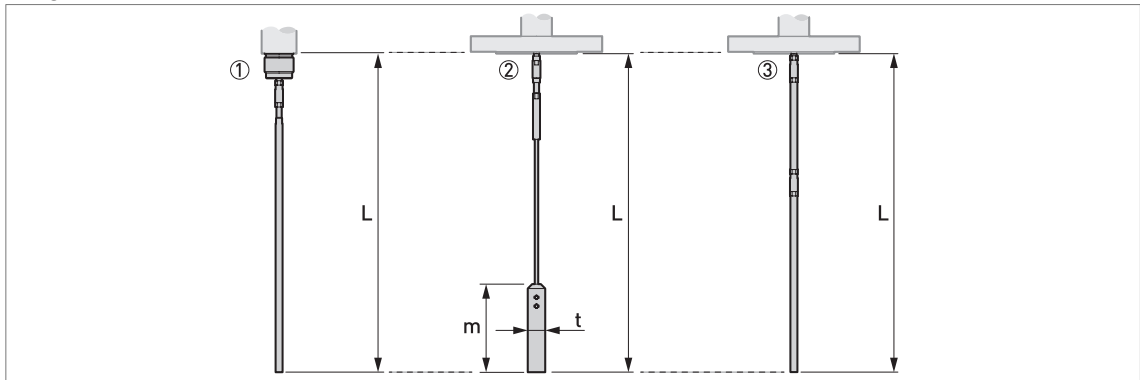

Figure 2-17: Single probes: options and overall dimensions

- ① Single rod $\varnothing 8$ mm / $\varnothing 0.32$ "
- ② Single cable $\varnothing 4$ mm / $\varnothing 0.16$ "
- ③ Single rod $\varnothing 8$ mm / $\varnothing 0.32$ " (segmented version)

Probe length, *L*, includes the length of the counterweight.

A wide range of counterweights are available. For dimensional data, refer to the pages that follow. For installation data, refer to the handbook.

Probes	Dimensions [mm]			
	L min.	L max.	m	t
Single rod $\varnothing 8$ mm	600	4000	—	—
Single cable $\varnothing 4$ mm	1000	60000	100 ①	$\varnothing 20$ ①
Single rod $\varnothing 8$ mm (segmented version)	600	6000	—	—

① If the probe has the counterweight option

Probes	Dimensions [inches]			
	L min.	L max.	m	t
Single rod $\varnothing 0.32$ "	24	158	—	—
Single cable $\varnothing 0.16$ "	39	2362	3.9 ①	$\varnothing 0.8$ ①
Single rod $\varnothing 0.32$ " (segmented version)	24	236	—	—

① If the probe has the counterweight option

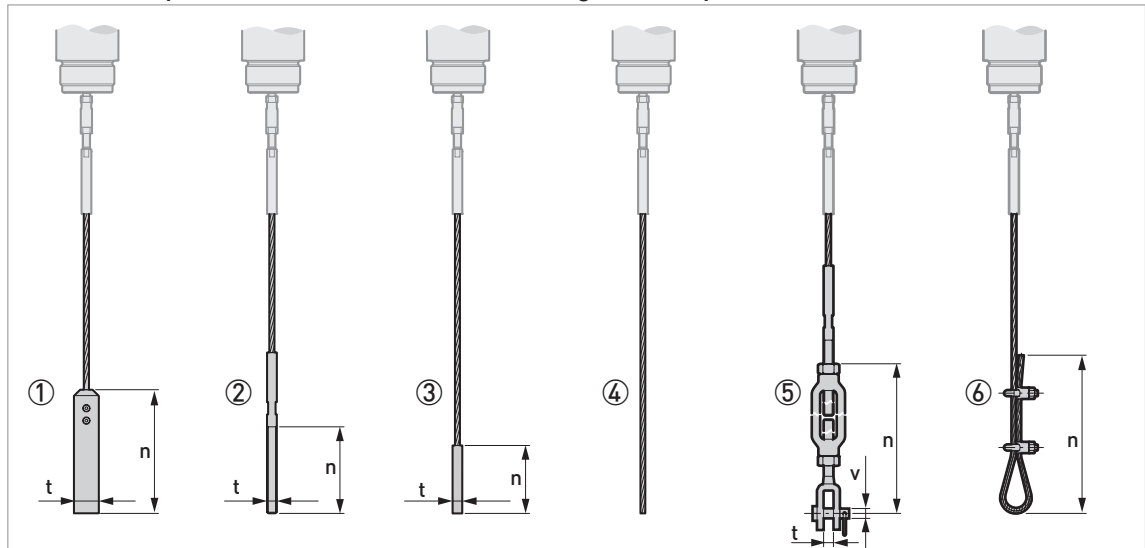
Probe end options for the $\varnothing 4$ mm / 0.16" single cable probeFigure 2-18: Probe end options for the $\varnothing 4$ mm / 0.16" single cable probe

- ① Standard counterweight
- ② Threaded end
- ③ Crimped end
- ④ Open end
- ⑤ Turnbuckle
- ⑥ Chuck

Probe end type	Dimensions [mm]		
	n	t	v
Counterweight	100	$\varnothing 20$	—
Threaded end	70	M8	—
Crimped end	55	$\varnothing 8$	—
Open end	—	—	—
Turnbuckle	172 ①	11	$\varnothing 6$
Chuck	300	—	—

① Minimum length

Probe end type	Dimensions [inches]		
	n	t	v
Counterweight	3.9	$\varnothing 0.8$	—
Threaded end	2.8	M8	—
Crimped end	2.2	$\varnothing 0.3$	—
Open end	—	—	—
Turnbuckle	6.8 ①	0.4	$\varnothing 0.2$
Chuck	11.8	—	—

① Minimum length

Coaxial probe: options and overall dimensions

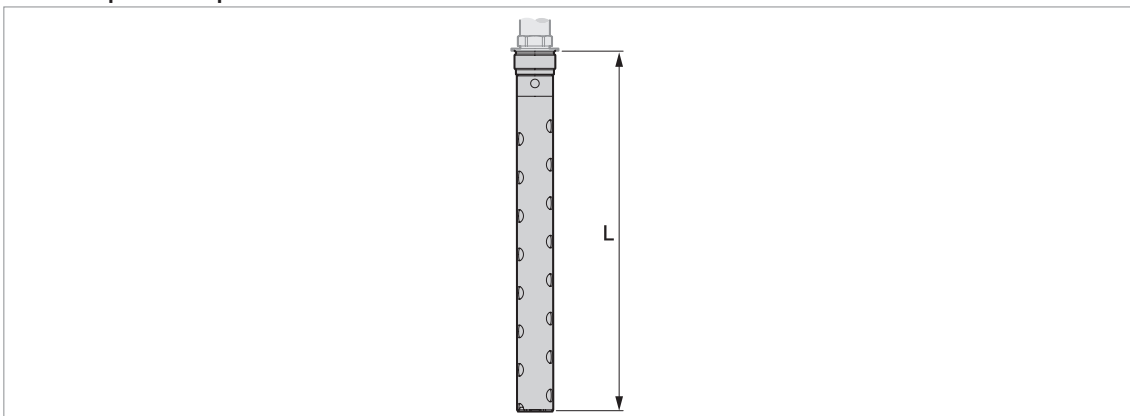

Figure 2-19: Coaxial probe: options and overall dimensions

Coaxial Ø42 mm / Ø1.65"

Probes	Dimensions [mm]			
	L min.	L max.	q	t
Coaxial Ø42 mm	600 ①	6000	—	—

① A shorter probe length is available on request

Probes	Dimensions [inches]			
	L min.	L max.	q	t
Coaxial Ø1.65"	24 ①	236	—	—

① A shorter probe length is available on request

Probe weights

Probes	Process seal system	Process connection	Process connection weights		Probe Weights	
			[kg]	[lb]	[kg/m]	[lb/ft]
Coaxial Ø42 mm / Ø1.65"	Single seal (ceramic)	Threaded	2.0...2.5	4.4...5.5	3.2 ①	2.15 ①
		Flange	3.5...70.0	7.7...154.3		
	Double seal (ceramic)	Threaded	3.2...3.7	7.1...8.2		
		Flange	4.0...71.0	8.8...156.5		
Single rod Ø8 mm / Ø0.32" (single-piece or segmented)	Single seal (ceramic)	Threaded	2.0...2.5	4.4...5.5	0.41 ①	0.28 ①
		Flange	3.5...70.0	7.7...154.3		
	Double seal (ceramic)	Threaded	3.2...3.7	7.1...8.2		
		Flange	4.0...71.0	8.8...156.5		
Single cable Ø4 mm / Ø0.16"	Single seal (ceramic)	Threaded	2.0...2.5	4.4...5.5	0.12 ②	0.08 ②
		Flange	3.5...70.0	7.7...154.3		
	Double seal (ceramic)	Threaded	3.2...3.7	7.1...8.2		
		Flange	4.0...71.0	8.8...156.5		

① This value does not include the weight of the process connection

② This value does not include the weights of the counterweight or the process connection

2.5.6 Weather protection option

Vertical signal converters

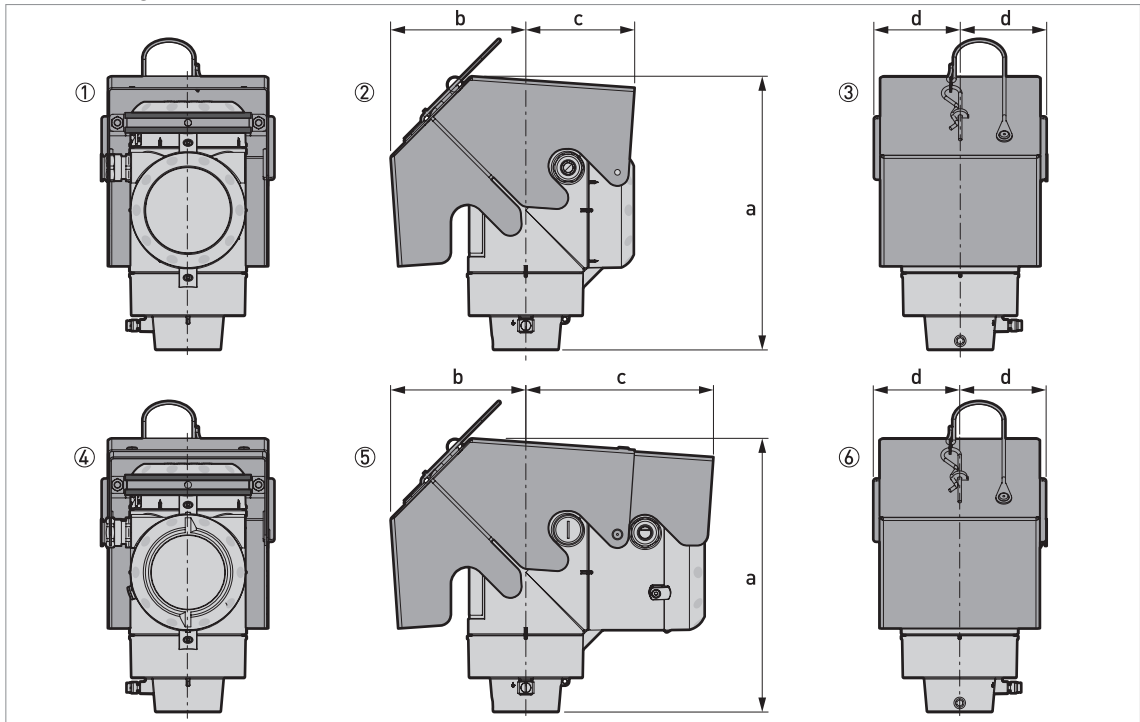

Figure 2-20: Vertical signal converters

- ① Non-Ex / Ex i / IS: Rear view (with weather protection closed)
- ② Non-Ex / Ex i / IS: Right side (with weather protection closed)
- ③ Non-Ex / Ex i / IS: Front view (with weather protection closed)
- ④ Optional output / Ex d / XP: Rear view (with weather protection closed)
- ⑤ Optional output / Ex d / XP: Right side (with weather protection closed)
- ⑥ Optional output / Ex d / XP: Front view (with weather protection closed)

Weather protection	Version	Dimensions [mm]				Weights [kg]
		a	b	c	d	
Vertical signal converter	Non-Ex / Ex i / IS	241	118	96	77	1.3
	Optional output / Ex d / XP	241	118	166	77	1.5

Weather protection	Version	Dimensions [inches]				Weights [lb]
		a	b	c	d	
Vertical signal converter	Non-Ex / Ex i / IS	9.5	4.6	3.8	3.0	2.9
	Optional output / Ex d / XP	9.5	4.6	6.5	3.0	3.3

Horizontal signal converters

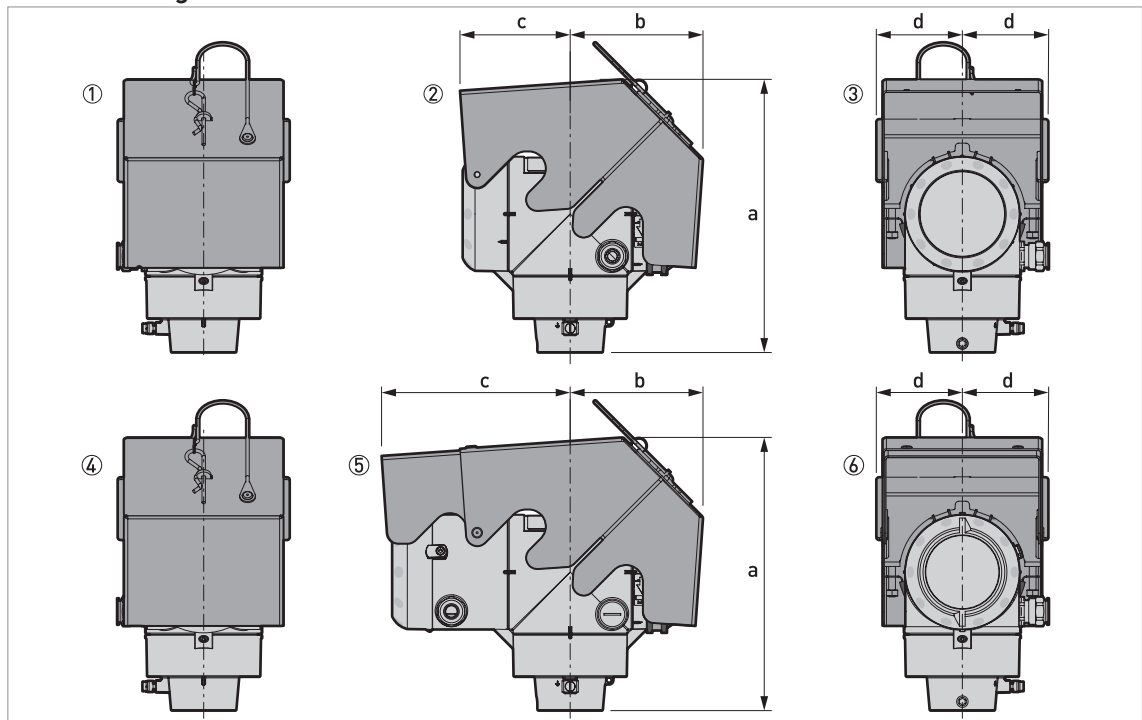

Figure 2-21: Horizontal signal converters

- ① Non-Ex / Ex i / IS: Front view (with weather protection closed)
- ② Non-Ex / Ex i / IS: Left side (with weather protection closed)
- ③ Non-Ex / Ex i / IS: Rear view (with weather protection closed)
- ④ Optional output / Ex d / XP: Front view (with weather protection closed)
- ⑤ Optional output / Ex d / XP: Left side (with weather protection closed)
- ⑥ Optional output / Ex d / XP: Rear view (with weather protection closed)

Weather protection	Version	Dimensions [mm]				Weights [kg]
		a	b	c	d	
Horizontal signal converter	Non-Ex / Ex i / IS	243	118	96	77	1.3
	Optional output / Ex d / XP	243	118	166	77	1.5

Weather protection	Version	Dimensions [inches]				Weights [lb]
		a	b	c	d	
Horizontal signal converter	Non-Ex / Ex i / IS	9.6	4.6	3.8	3.0	2.9
	Optional output / Ex d / XP	9.6	4.6	6.5	3.0	3.3

3.1 Intended use

Responsibility for the use of the measuring devices with regard to suitability, intended use and corrosion resistance of the used materials against the measured fluid lies solely with the operator.

The manufacturer is not liable for any damage resulting from improper use or use for other than the intended purpose.

This TDR level transmitter measures distance, level, interface, mass and volume of liquids, pastes and slurries.

It can be installed on tanks and reactors.

3.2 How to prepare the tank before you install the device

To avoid measuring errors and device malfunction, obey these precautions.

3.2.1 General information for nozzles

Follow these recommendations to make sure that the device measures correctly. They have an effect on the performance of the device.

Do not put the process connection near to the product inlet. If the product that enters the tank touches the probe, the device will measure incorrectly.

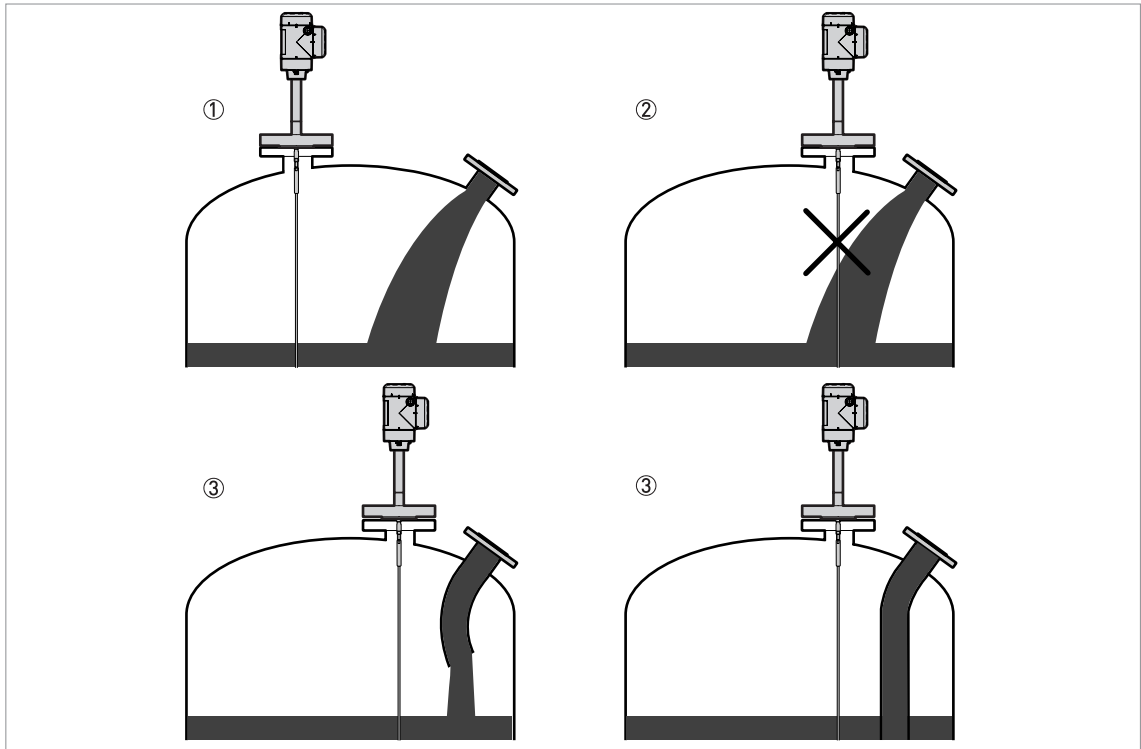

Figure 3-1: Do not put the device near to a product inlet

- ① The device is in the correct position.
- ② The device is too near to the product inlet.
- ③ If it is not possible to put the device in the recommended position, install a deflector pipe.

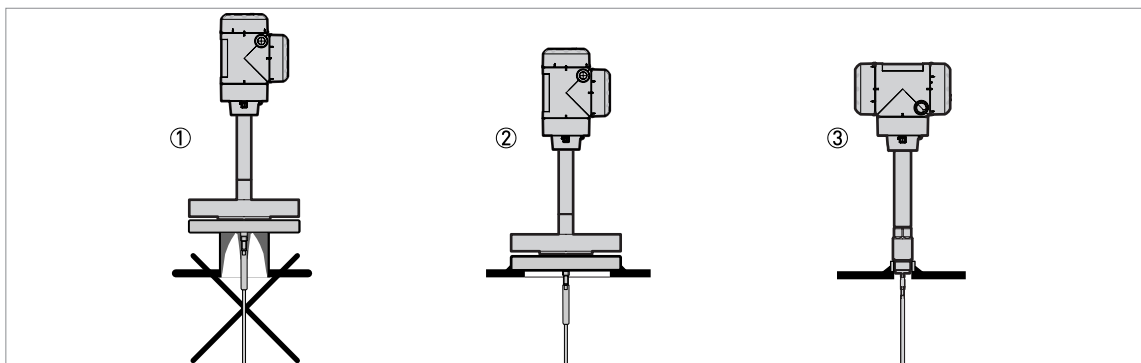

Figure 3-2: How to prevent build-up of product around the process connection

- ① If product particles are likely to collect in holes, a nozzle is not recommended.
- ② Attach the flange directly to the tank.
- ③ Use a threaded connection to attach the device directly to the tank.

For single cable and single rod probes:

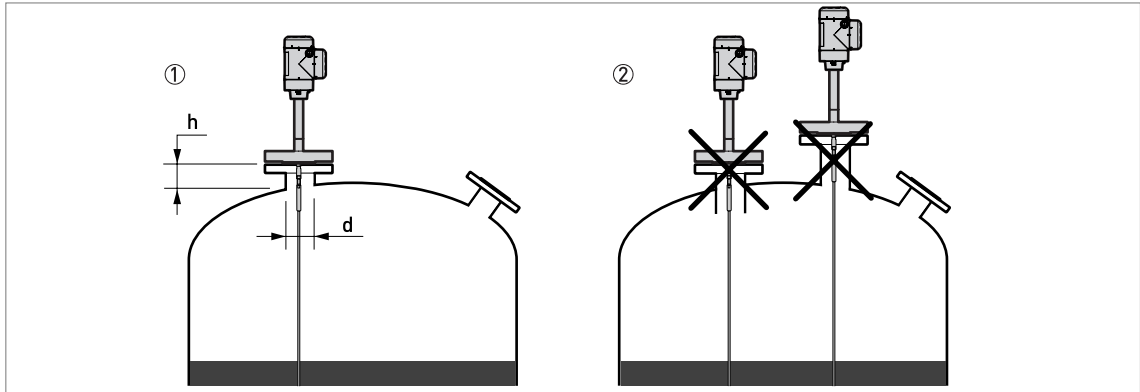

Figure 3-3: Recommended nozzle dimensions for single rod and single cable probes

- ① Recommended conditions: $h \leq d$, where h is the height of the tank nozzle and d is the diameter of the tank nozzle.
- ② The end of the nozzle must not have an extension into the tank. Do not install the device on a high nozzle.

If the device is installed on a high nozzle, make sure that the probe does not touch the side of the nozzle (attach the probe end etc.).

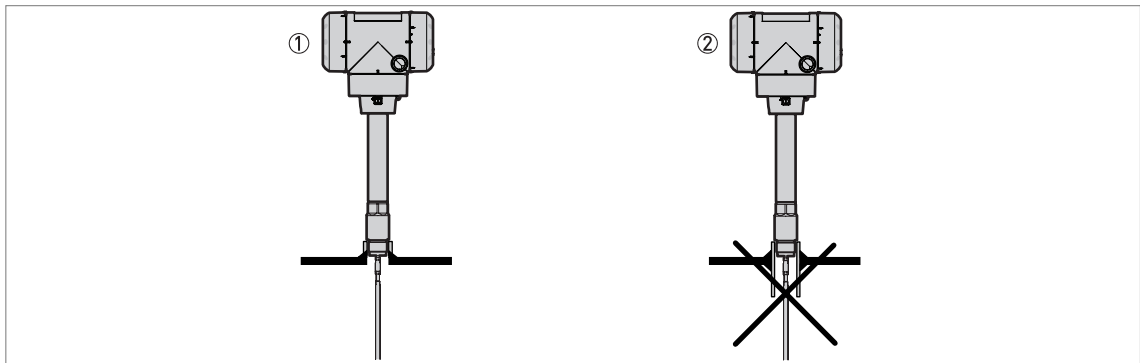

Figure 3-4: Sockets for threaded process connections

- ① Recommended installation
- ② The end of the socket must not have an extension into the tank

For coaxial probes:

If your device has a coaxial probe, you can ignore the installation recommendations in this section. But:

Install the $\varnothing 42 / 1.65''$ coaxial probe in clean liquids that have a viscosity less than 2000 Pa·s / 2000 cP.

3.3 Installation recommendations for liquids

3.3.1 General requirements

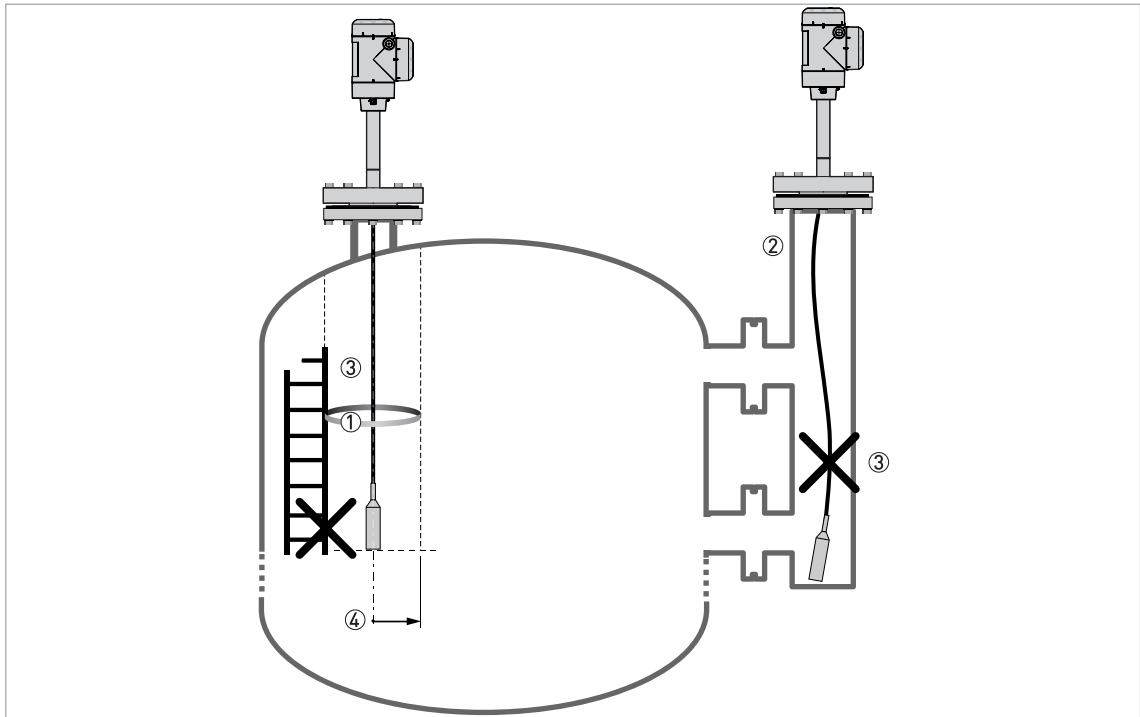

Figure 3-5: Installation recommendations for liquids

- ① The electromagnetic (EM) field generated by the device. It has a radius of R_{min} . Make sure that the EM field is clear of objects and product flow. Refer to the table that follows.
- ② If there are too many objects in the tank, install a bypass chamber or stilling well
- ③ Keep the probe straight. If the probe is too long, shorten the probe length. Make sure that the device is configured with the new probe length. For more data on the procedure, refer to the handbook.
- ④ Empty space. Refer to the table that follows.

Clearance between the probe and other objects in the tank

Probe type	Empty space (radius, R_{min}), around the probe	
	[mm]	[inches]
Coaxial	0	0
Single rod / cable	300	12

3.3.2 Installation in standpipes (stilling wells and bypass chambers)

Use a standpipe if:

- The liquid is very turbulent or agitated.
- There are too many other objects in the tank.
- The device is measuring a liquid in a tank with a floating roof.

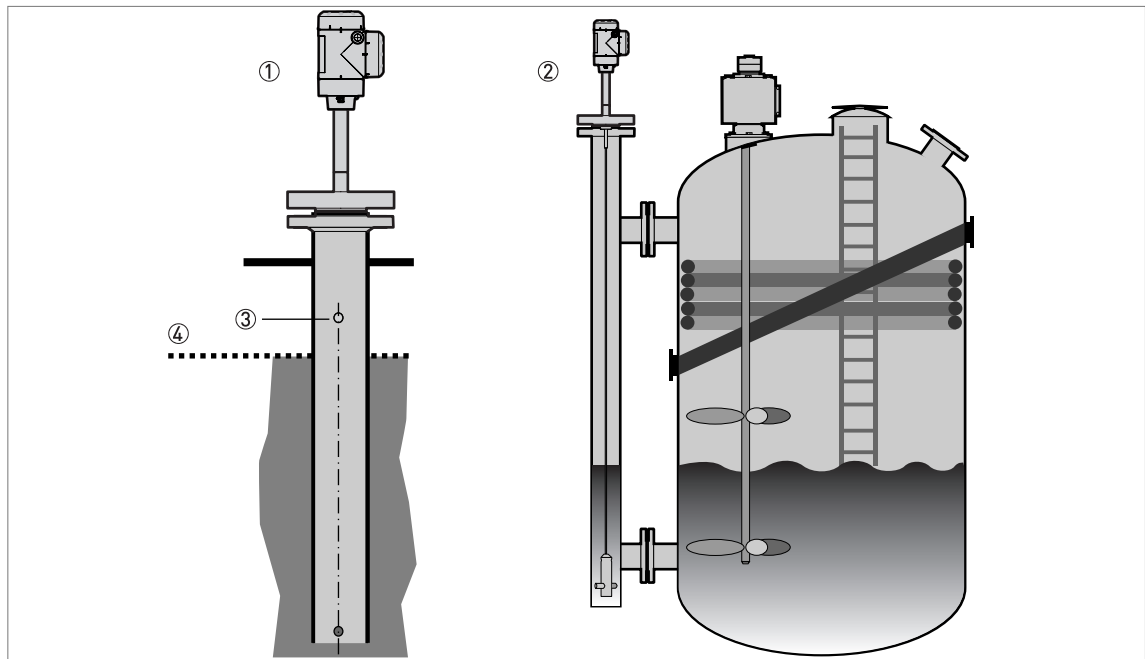

Figure 3-6: Installation recommendations for standpipes (stilling wells and bypass chambers)

- ① Stilling well
- ② Bypass chamber
- ③ Vent
- ④ Level of the liquid

Stilling wells are not necessary for devices with coaxial probes. But if there is a sudden change in diameter in the stilling well, we recommend that you install a device with a coaxial probe.

- *The standpipe must be electrically conductive. If the standpipe is not made of metal, obey the instructions for empty space around the probe. For more data, refer to General requirements on page 45.*
- *The standpipe must be straight. There must be no changes in diameter from the device process connection to the bottom of the standpipe.*
- *The standpipe must be vertical.*
- *Recommended surface roughness: $< \pm 0.1 \text{ mm} / 0.004''$.*
- *The bottom of the stilling well must be open.*
- *Adjust the probe to the center of the standpipe.*
- *Make sure that there are no deposits at the bottom of the standpipe which can cause blockage of the process connections.*
- *Make sure that there is liquid in the standpipe.*

Floating roofs

If the device is for a tank with a floating roof, install it in a stilling well.

4.1 Electrical installation: 2-wire, loop-powered

4.1.1 Compact version

Output 1 energizes the device and is used for HART® communication. If the device has the second current output option, use a separate power supply to energize output 2. If the device has a switch output - relay option, use a separate power supply (connect the power supply to the switch power supply terminals).

Terminals for electrical installation (one output)

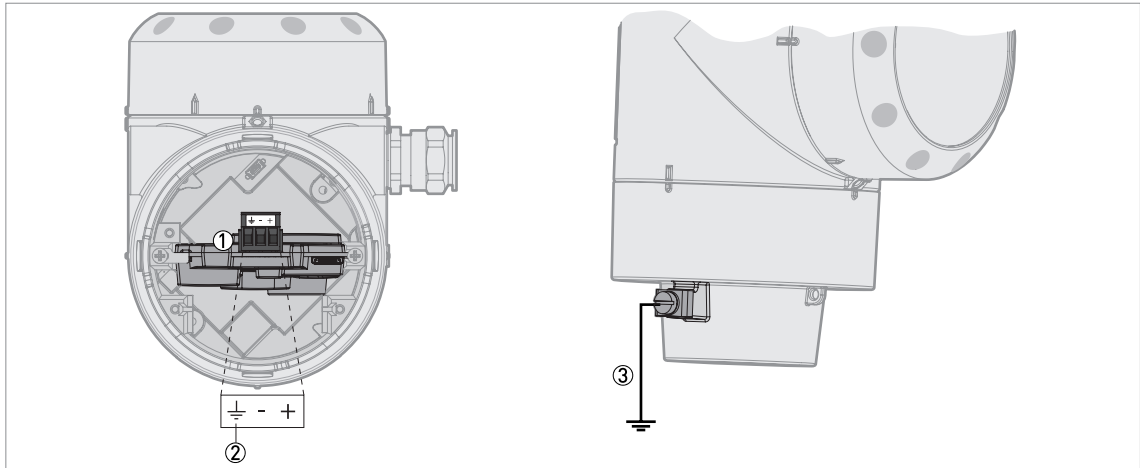

Figure 4-1: Terminals for electrical installation (one output)

- ① Current output 1
- ② Grounding terminal in the housing (if the electrical cable is shielded)
- ③ Location of the external grounding terminal (at the bottom of the converter)

Terminals for electrical installation (two current outputs)

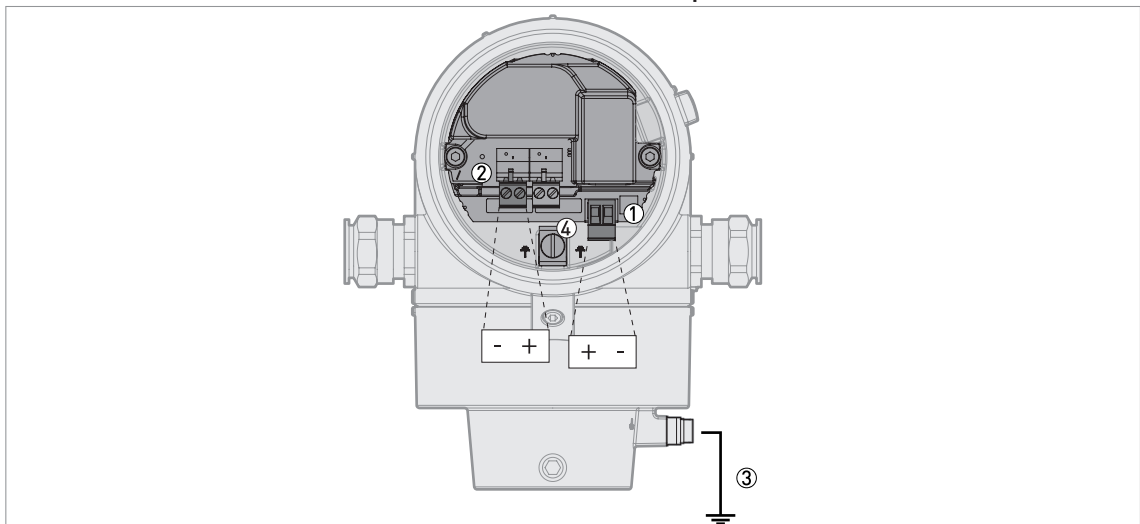

Figure 4-2: Terminals for electrical installation (two current outputs)

- ① Output 1: Terminals
- ② Output 2: Terminals
- ③ Location of the external grounding terminal (at the bottom of the converter)
- ④ Grounding terminal in the housing (if the electrical cable is shielded)

Terminals for electrical installation (one current output and one switch output - relay)

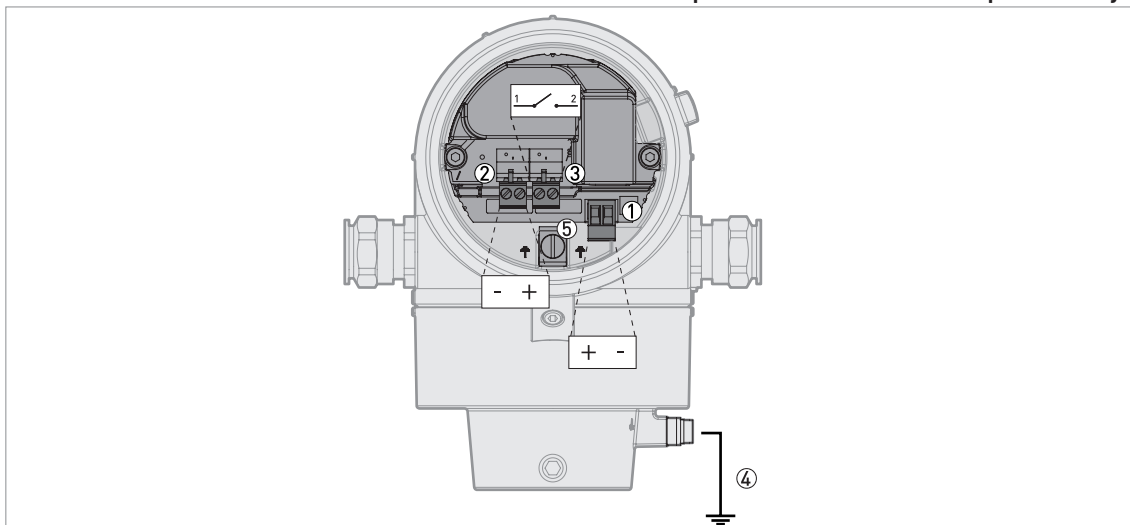

Figure 4-3: Terminals for electrical installation (one current output and one switch output - relay)

- ① Current output 1: Terminals
- ② Switch power supply: Terminals
- ③ Switch output - relay: Terminals
- ④ Location of the external grounding terminal (at the bottom of the converter)
- ⑤ Grounding terminal in the housing (if the electrical cable is shielded)

4.1.2 Remote version

Output 1 energizes the device and is used for HART® communication. If the device has the second current output option, use a separate power supply to energize output 2. If the device has a switch output - relay option, use a separate power supply (connect the power supply to the switch power supply terminals).

Terminals for electrical installation (one output)

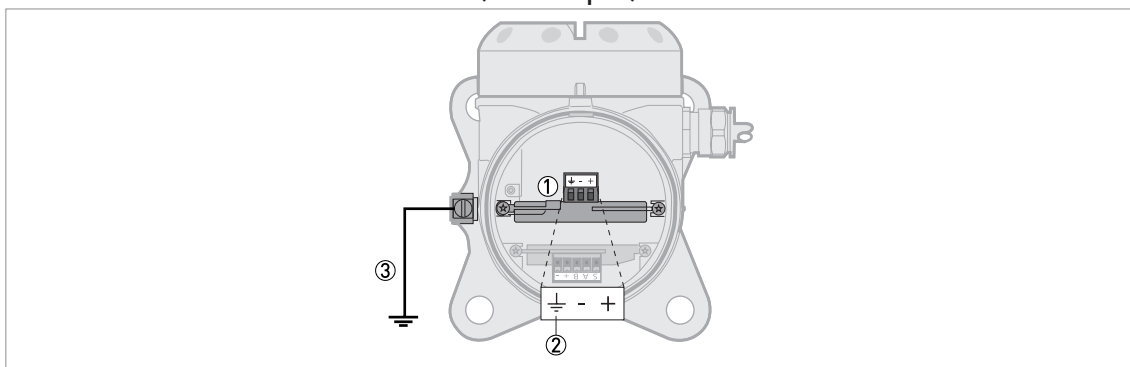

Figure 4-4: Terminals for electrical installation (one output)

- ① Current output 1: Terminals
- ② Grounding terminal in the housing (if the electrical cable is shielded)
- ③ Location of the external grounding terminal (on the wall support)

Terminals for electrical installation (two current outputs)

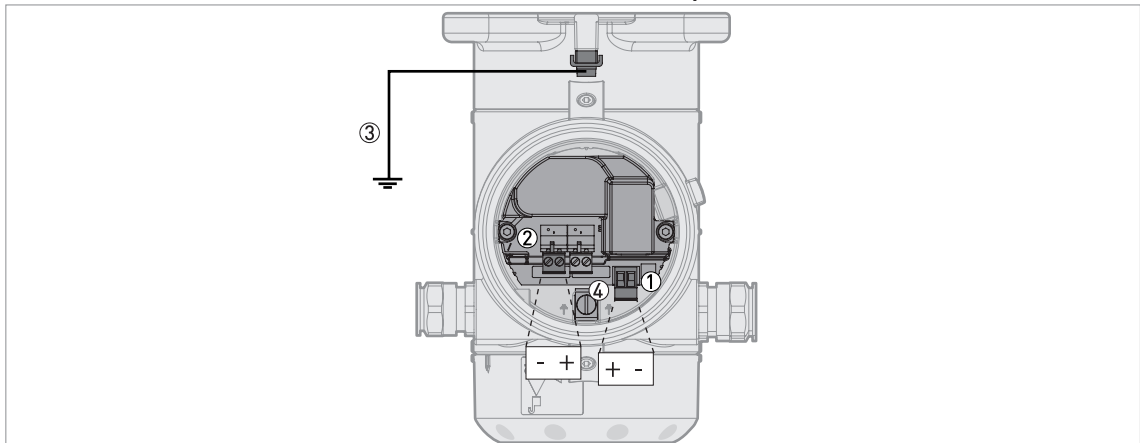

Figure 4-5: Terminals for electrical installation (two current outputs)

- ① Output 1: Terminals
- ② Output 2: Terminals
- ③ Location of the external grounding terminal (on the wall support)
- ④ Grounding terminal in the housing (if the electrical cable is shielded)

Terminals for electrical installation (one current output / one switch output - relay)

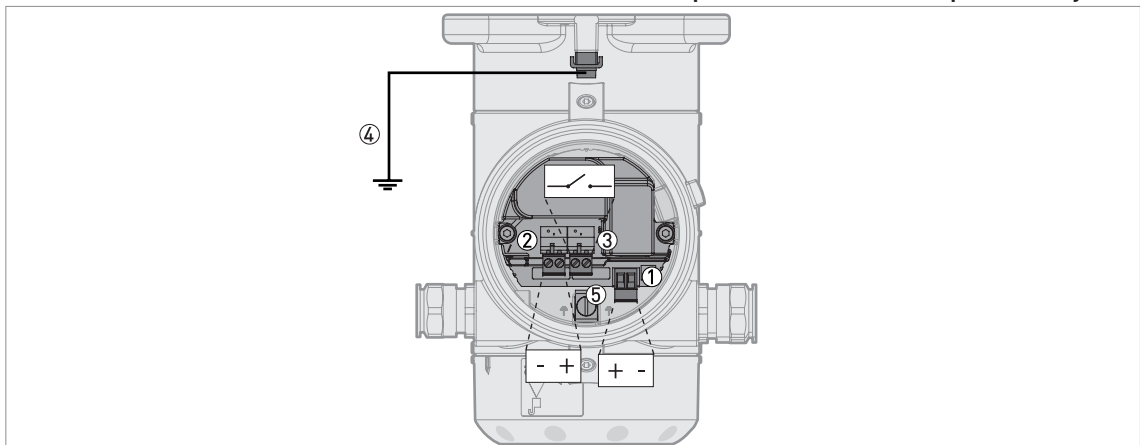

Figure 4-6: Terminals for electrical installation (one current output / one switch output - relay)

- ① Current output 1: Terminals
- ② Switch power supply: Terminals
- ③ Switch output - relay: Terminals
- ④ Location of the external grounding terminal (on the wall support)
- ⑤ Grounding terminal in the housing (if the electrical cable is shielded)

Connections between the remote converter and the probe housing (one output)

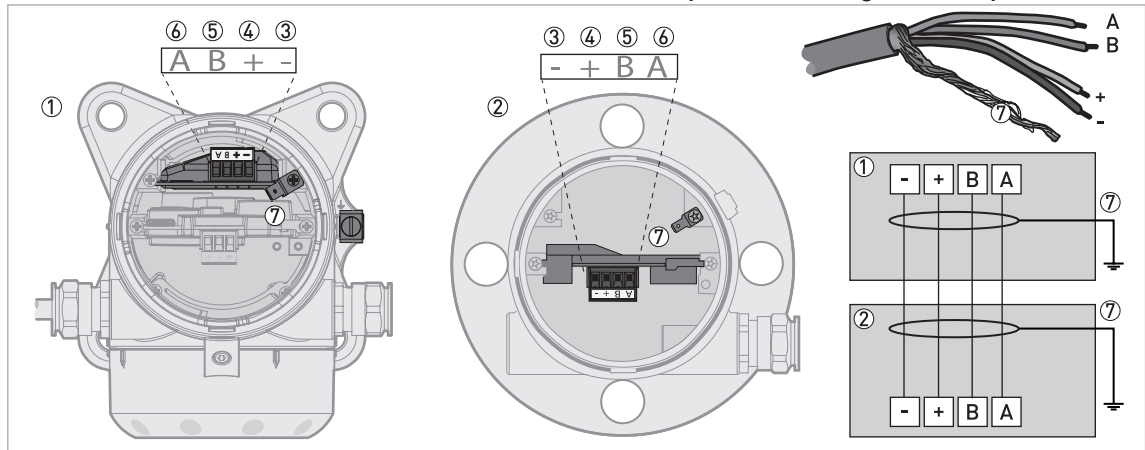

Figure 4-7: Connections between the remote converter and the probe housing (one output)

- ① Remote converter
- ② Probe housing
- ③ Power supply: voltage in -
- ④ Power supply: voltage in +
- ⑤ Signal cable B
- ⑥ Signal cable A
- ⑦ Shielding wire (attached to Faston connectors in the housings of the remote converter and the probe housing)

4.2 Non-Ex devices

Two current outputs and the switch output - relay are supplied together as a device option. Two current outputs or the switch output - relay are only available if you send an order for a device with these options.

For more data about current output functions, the switch function and related settings, refer to the "Operation" chapter in the handbook.

One current output

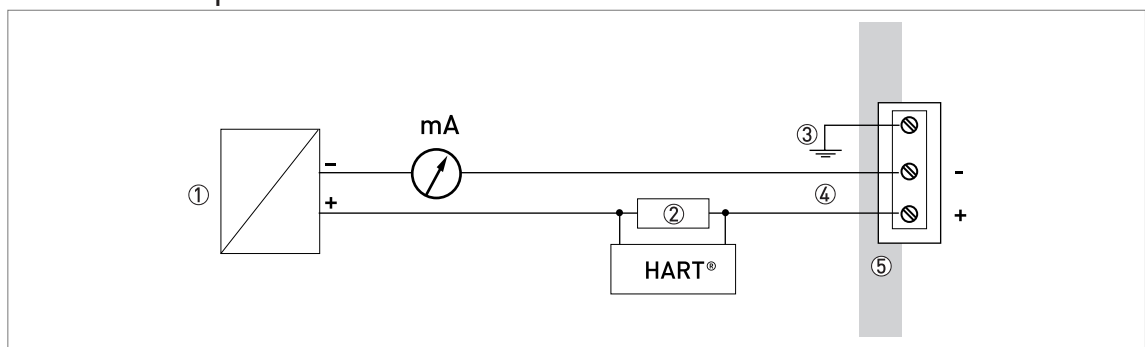

Figure 4-8: Electrical connections for non-Ex devices (one current output)

- ① Power supply
- ② Resistor for HART® communication
- ③ Optional connection to the grounding terminal
- ④ Output: 11.5...30 V DC for an output of 22 mA at the terminal
- ⑤ Device

Two current outputs

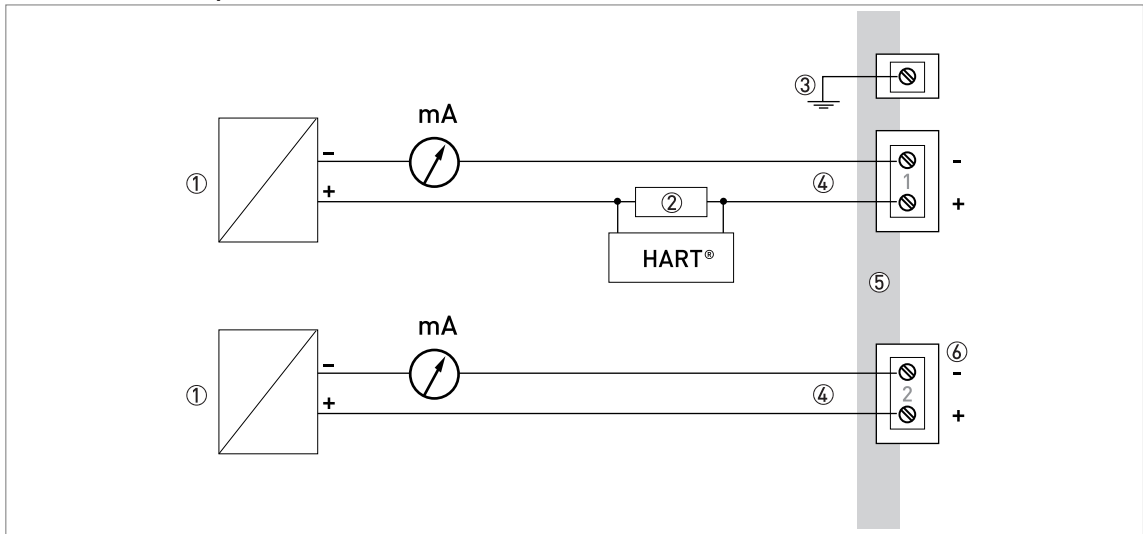

Figure 4-9: Electrical connections for non-Ex devices (two current outputs)

- ① Power supply
- ② Resistor for HART® communication
- ③ Optional connection to the grounding terminal
- ④ Output 1 and 2: 11.5...30 V DC for an output of 22 mA at the terminals
NOTE: Use a separate power supply to energize output 2
- ⑤ Device
- ⑥ Connector for the optional second output

One current output and one switch output - relay

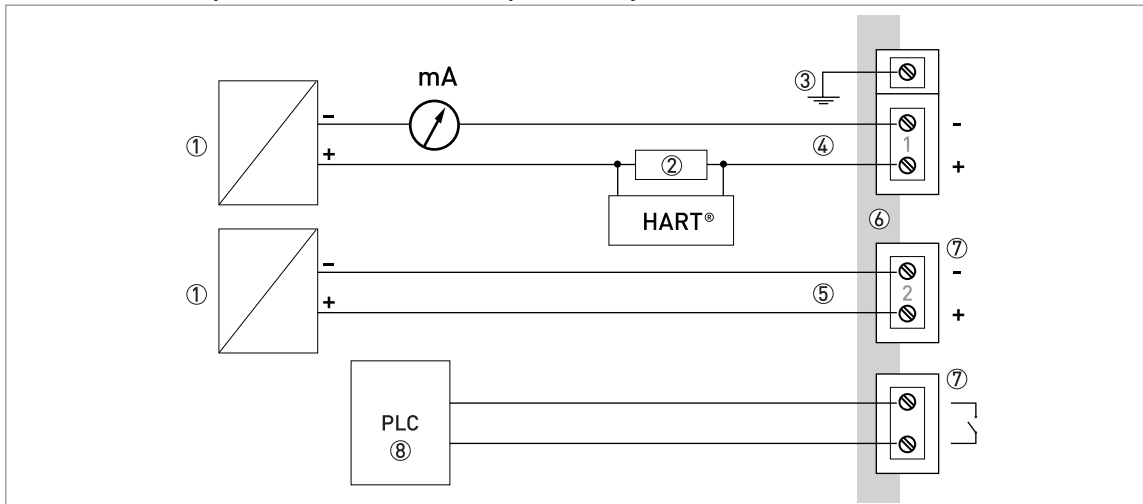

Figure 4-10: Electrical connections for non-Ex devices (one current output and one switch output - relay)

- ① Power supply
- ② Resistor for HART® communication
- ③ Optional connection to the grounding terminal
- ④ Output 1: 11.5...30 V DC for an output of 22 mA at the terminals
- ⑤ Switch power supply [2]: 11.5...34 V DC / 30 mA
NOTE: Use a separate power supply to energize the switch output - relay option
- ⑥ Device
- ⑦ Connector for the switch output - relay
- ⑧ PLC (for example)

4.3 Devices for hazardous locations

For electrical data for device operation in hazardous locations, refer to the related certificates of compliance and supplementary instructions (ATEX, IECEx etc.). This documentation can be downloaded from the website (Download Center).

4.4 Networks

4.4.1 General information

The device uses the HART® communication protocol. This protocol agrees with the HART® Communication Foundation standard. The device can be connected point-to-point. It can also have a polling address of 1 to 63 in a multi-drop network.

The device output is factory-set to communicate point-to-point. To change the communication mode from **point-to-point** to **multi-drop**, refer to "Network configuration" in the handbook.

4.4.2 Point-to-point networks

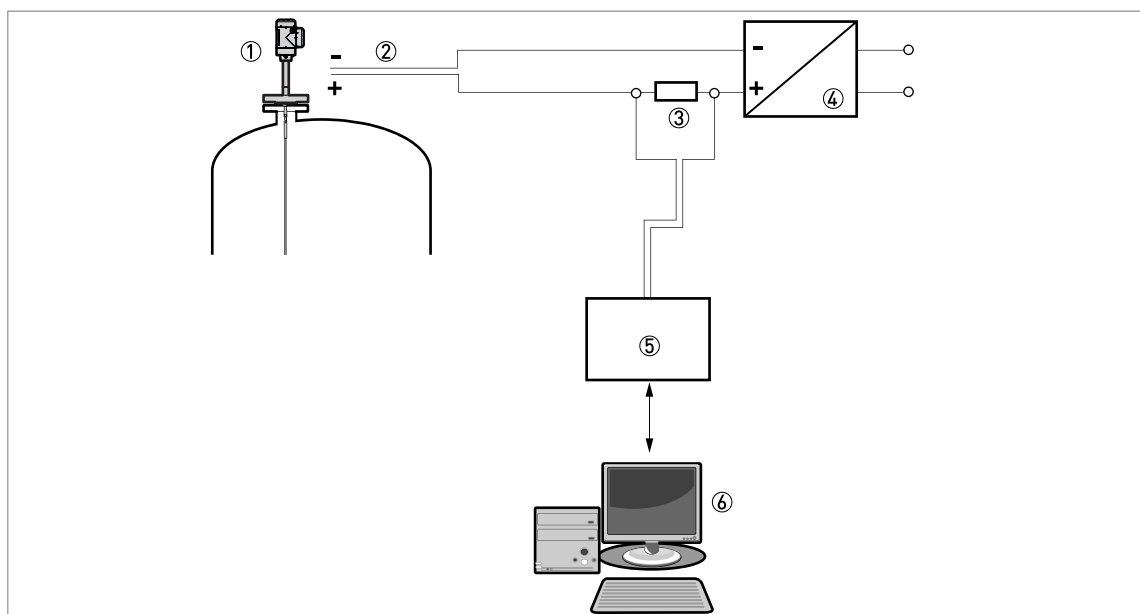

Figure 4-11: Point-to-point connection (non-Ex)

- ① Address of the device (0 for a point-to-point connection)
- ② 4...20 mA + HART®
- ③ Resistor for HART® communication
- ④ Power supply
- ⑤ HART® modem
- ⑥ HART® communication device

4.4.3 Multi-drop networks

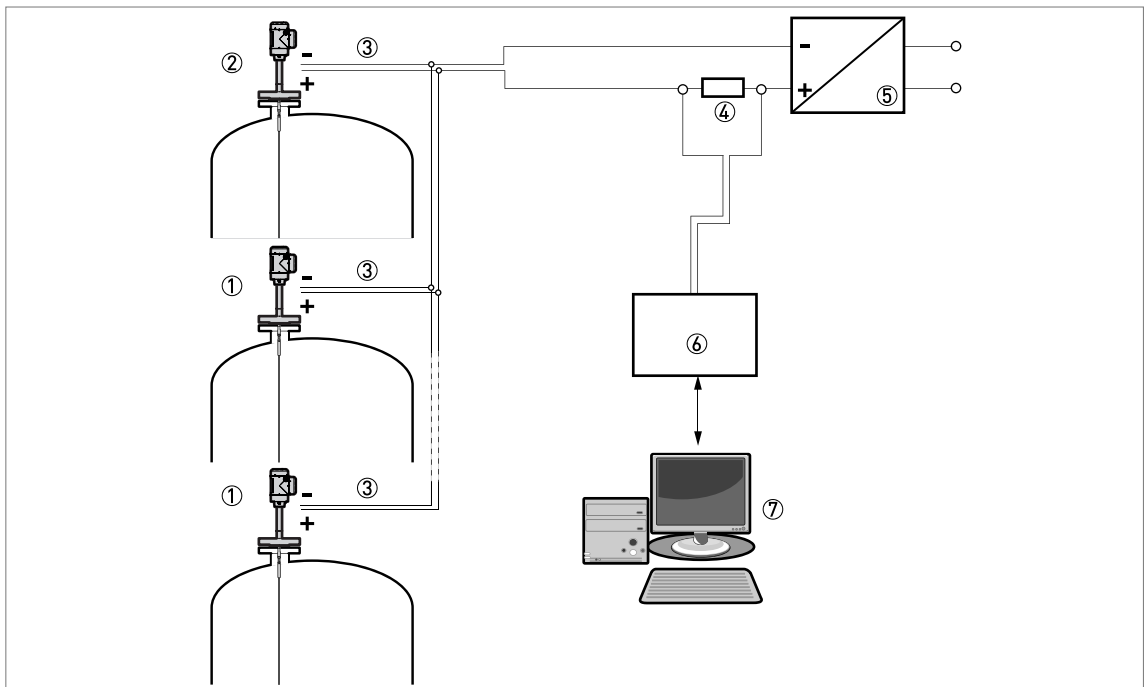

Figure 4-12: Multi-drop network (non-Ex)

- ① Address of the device (n+1 for multidrop networks)
- ② Address of the device (1 for multidrop networks)
- ③ 4 mA + HART®
- ④ Resistor for HART® communication
- ⑤ Power supply
- ⑥ HART® modem
- ⑦ HART® communication device

5.1 Order code

Make a selection from each column to get the full order code. The characters of the order code highlighted in light grey describe the standard.

VFAC	4	0	OPTIFLEX 8200 C/F/S Guided Radar (TDR) level transmitter for liquids at high temperature and pressure up to 320 barg (4641 psig) and +315°C (+599°F)
			Regional directives and approvals
		1	Europe
		2	China
		3	USA
		4	Canada
		5	Brazil
		6	Australia
		A	Russia
		B	Kazakhstan
		C	Belarus
		W	Worldwide
			Ex approval ①
		0	Without
		1	ATEX II 1/2 G Ex ia IIC T6...T* Ga/Gb + II 1/2 D Ex ia IIIC T85°C...T*°C Da/Db ②
		2	ATEX II 1/2 G Ex ia/db IIC T6...T3 Ga/Gb + II 1/2 D Ex ia/tb IIIC T85°C...T*°C Da/Db ②
		3	ATEX II 3 G Ex ic IIC T6...T* Gc + II 3 D Ex ic IIIC T85°C...T*°C Dc ②
		4	ATEX II 3 G Ex ic nA T6...T* Gc ③
		5	NEPSI Ex ia IIC T*~T6 Ga/Gb + Ex iaD 20/21 T85~T** ②
		6	NEPSI Ex d ia IIC T*~T6 Ga/Gb + Ex iaD 20 tD A21 IP6X T85°C~T*°C ②
		A	cQPSus IS CL I/II/III DIV 1 GP A-G + CL I Z0 AEx ia/Ex ia IIC T6...T* Ga + Z20 AEx ia/Ex ia IIIC T85°C...T*°C Da ②
		B	cQPSus XP-IS/DIP-IS CL I DIV 1 GP A-G + CL I Z1 AEx db ia/Ex db ia IIC T6...T* Gb + Z21 AEx ia tb/Ex ia tb IIIC T85°C...T*°C Db ②
		C	cQPSus NI CL I/II/III DIV 2 GP ABCDFG
		K	IECEEx Ex ia IIC T6...T* Ga/Gb + Ex ia IIIC T85°C...T*°C Da/Db ②
		L	IECEEx Ex ia/db IIC T6...T* Ga/Gb + Ex ia/tb IIIC T85°C...T*°C Da/Db ②
		M	IECEEx Ex ic IIC T6...T* Gc + Ex ic IIIC T85°C...T*°C Dc ②
		P	EAC Ex Ga/Gb Ex ia T6...T* X + Da/Db Ex ia IIIC T85°C...T*°C X (Pending) ②
		R	EAC Ex Ga/Gb Ex ia/db IIC T6...T* X + Da/Db Ex ia/tb IIIC T85°C...T*°C X (Pending) ②
			Industry/Safety
		0	Without
		1	SIL2/3 – only available for the compact (C) and sensor extension (S) versions
VFAC	4	0	Order code (complete this code on the pages that follow)







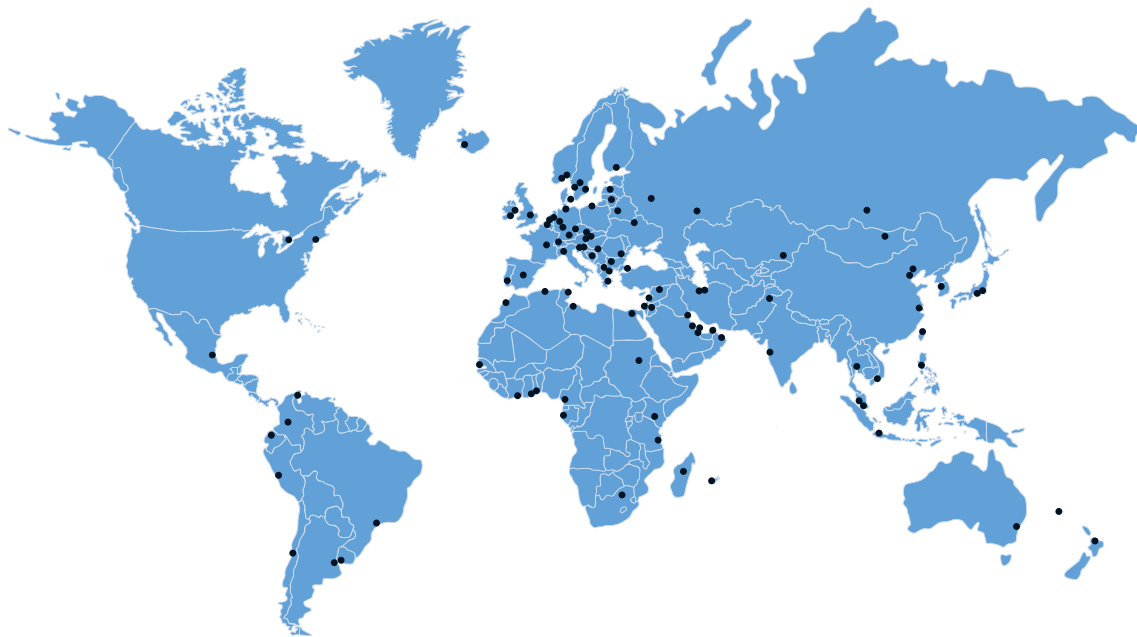

KROHNE – Process instrumentation and measurement solutions

- Flow
- Level
- Temperature
- Pressure
- Process Analysis
- Services

Head Office KROHNE Messtechnik GmbH
Ludwig-Krohne-Str. 5
47058 Duisburg (Germany)
Tel.: +49 203 301 0
Fax: +49 203 301 10389
info@krohne.com

The current list of all KROHNE contacts and addresses can be found at:
www.krohne.com

KROHNE