

INSTRUCTION MANUAL

SIL 3 Repeater Power Supply
Hart, DIN-Rail and Termination Board,
Models D5014S, D5014D



Characteristics

General Description: The single and dual channel Repeater Power Supply, D5014S and D5014D module is a high integrity analog input interface suitable for applications requiring SIL 3 level (according to IEC 61508:2010 Ed.2) in safety related systems for high risk industries. Provides a fully floating dc supply for energizing conventional 2 wires 4-20 mA, active or passive, transmitters located in Hazardous Area, and repeats the current in floating circuit to drive a Safe Area load. The circuit allows bi-directional communication signals, for Hart transmitters.

Mounting on standard DIN-Rail, with or without Power Bus, or on customized Termination Boards, in Safe Area / Non Hazardous Location or in Zone 2 / Class I, Division 2 or Class I, Zone 2.

Functional Safety Management Certification:

G.M. International is certified by TUV to conform to IEC61508:2010 part 1 clauses 5-6 for safety related systems up to and included SIL3.



Technical Data

Supply: 24 Vdc nom (18 to 30 Vdc) reverse polarity protected, ripple within voltage limits ≤ 5 Vpp, 2 A time lag fuse internally protected.

Current consumption @ 24 V: 90 mA for 2 channels D5014D, 45 mA for 1 channel D5014S with 20 mA output typical.

Power dissipation: 1.35 W for 2 channels D5014D, 0.675 W for 1 channel D5014S with 24 V supply voltage and 20 mA output typical.

Isolation (Test Voltage): I.S. In/Out 2.5 KV; I.S. In/Supply 2.5 KV; I.S. In/I.S. In 500 V; Out/Supply 500 V; Out/Out 500 V.

Input: 4 to 20 mA (separately powered input, voltage drop ≤ 0.5 V) or 4 to 20 mA (2 wires Tx current limited at ≈ 25 mA), reading range 0 to 24 mA.

Transmitter line voltage: 15.0 V typical at 20 mA with max. 20 mVrms ripple on 0.5 to 2.5 KHz frequency band, 14.5 V minimum.

Output: 4 to 20 mA, on max. 550 Ω load in source mode (typical 12 V compliance);

V min. 8 V at 0 Ω load V max. 30 V in sink mode, current limited at ≈ 25 mA or 1 to 5 V on internal 250 Ω shunt.

Response time: 5 ms (0 to 100 % step change).

Output ripple: ≤ 20 mVrms on 250 Ω communication load on 0.5 to 2.5 KHz band.

Frequency response: 0.5 to 2.5 KHz bidirectional within 3 dB (Hart protocol).

Performance: Ref. Conditions 24 V supply, 250 Ω load, 23 ± 1 °C ambient temperature.

Calibration accuracy: $\leq \pm 0.1$ % of full scale.

Linearity error: $\leq \pm 0.05$ % of full scale.

Supply voltage influence: $\leq \pm 0.02$ % of full scale for a min to max supply change.

Load influence: $\leq \pm 0.02$ % of full scale for a 0 to 100 % load resistance change.

Temperature influence: $\leq \pm 0.01$ % of full scale on zero and span for a 1 °C change.

Compatibility:



CE mark compliant, conforms to Directive: 2014/34/EU ATEX, 2014/30/EU EMC, 2014/35/EU LVD, 2011/65/EU RoHS.

Environmental conditions:

Operating: temperature limits - 40 to + 70 °C, relative humidity 95 %, up to 55 °C.

Storage: temperature limits - 45 to + 80 °C.

Max altitude: 2000 m a.s.l.

Safety Description:



ATEX: II 3(1)G Ex ec [ia Ga] IIC T4 Gc, II (1)D [Ex ia Da] IIIC, I (M1) [Ex ia Ma] I

IECEx / INMETRO: Ex ec [ia Ga] IIC T4 Gc, [Ex ia Da] IIIC, [Ex ia Ma] I

UL: NI / I / 2 / ABCD / T4, AIS / I, II, III / 1 / ABCDEFG, AEx nA [ia Ga] IIC T4 Gc

C-UL: NI / I / 2 / ABCD / T4, AIS / I, II, III / 1 / ABCDEFG, Ex nA [ia Ga] IIC T4 Gc

FM: NI-AIS / I / 2 / ABCD / T4, AIS / I,II,III / 1 / ABCDEFG, I / 2 / AEx nA [ia] / IIC / T4

FMC: NI-AIS / I / 2 / ABCD / T4, AIS / I,II,III / 1 / ABCDEFG, I / 2 / Ex nA [ia] / IIC / T4

EAC-EX: 2Ex ec [ia Ga] IIC T4 Gc X; [Ex ia Da] IIIC X; [Ex ia Ma] I X

CCC: Ex ec [ia Ga] IIC T4 Gc; [Ex ia Ga] IIC; [Ex ia Da] IIIC

KCs: Ex nA [ia Ga] IIC T4 Gc

associated apparatus and non-sparking electrical equipment.

Uo/Voc = 25.9 V, Io/Isc = 92 mA, Po/Po = 594 mW at terminals 7-8, 9-10.

Uo/Voc = 1.1 V, Io/Isc = 56 mA, Po/Po = 16 mW at terminals 8-11, 10-12.

Ui/Vmax = 30 V, Ii/Imax = 128 mA, Ci = 0 nF, Li = 0 nH at terminals 8-11, 10-12.

Um = 250 Vrms, -40 °C \leq Ta \leq 70 °C.

Approvals:

BVS 10 ATEX E 113 X conforms to EN60079-0, EN60079-7, EN60079-11.

IECEx BVS 10.0072 X conforms to IEC60079-0, IEC60079-7, IEC60079-11.

INMETRO DNV 13.0109 X conforms to ABNT NBR IEC60079-0, ABNT NBR IEC60079-7, ABNT NBR IEC60079-11.

UL & C-UL E222308 conforms to UL913, UL 60079-0, UL60079-11, UL60079-15, ANSI/ISA 12.12.01 for UL

and CSA-C22.2 No.157-92, CSA-E60079-0, CSA-E60079-11, CSA-C22.2 No. 213 and CSA-E60079-15 for C-UL.

FM 3046304 and FMC 3046304C conforms to Class 3600, 3610, 3810, 3611,

ANSI/ISA-60079-0, ANSI/ISA-60079-11, ANSI/ISA-60079-15, C22.2 No.142, C22.2 No.157, C22.2 No.213, C22.2 No. 60079-0, C22.2 No. 60079-11, C22.2 No. 60079-15.

EA3C RU C-IT.AA87.B.01310/24 conforms to GOST 31610.0, GOST 31610.7, GOST 31610.11.

CCC n. 2020322316000978 conforms to GB/T 3836.1, GB/T 3836.3, GB/T 3834.4

TC21005 for TIS approval.

KTL 21-KA4BO-0230X for KCs approval (for D5014S).

KTL 21-KA4BO-0231X for KCs approval (for D5014D).

TÜV Certificate No. C-IS-236198-04, SIL 2 / SIL 3 conforms to IEC61508:2010 Ed.2.

SIL 3 Functional Safety TÜV Certificate conforms to IEC61508:2010 Ed.2, for Management of Functional Safety.

DNV Type Approval Certificate No. TAA00001U0 and KR No.MIL20769-EL002 Certificates for maritime applications.

Mounting:

EN/IEC60715 TH 35 DIN-Rail with or without Power Bus or on customized Termination Board.

Weight: about 155 g D5014D, 130 g D5014S.

Connection: by polarized plug-in disconnect screw terminal blocks to accommodate terminations up to 2.5 mm².

Location: installation in Safe Area/Non Hazardous Locations or Zone 2, Group IIC T4 or Class I, Division 2, Group A,B,C,D, T4 or Class I, Zone 2, Group IIC, T4.

Protection class: IP 20.

Dimensions: Width 12.5 mm, Depth 123 mm, Height 120 mm.

Ordering Information

Model:	D5014	
1 channel		S
2 channels		D

Power Bus and DIN-Rail accessories:
 Connector JDFT049 Cover and fix MCHP196
 Terminal block male MOR017 Terminal block female MOR022

Front Panel and Features

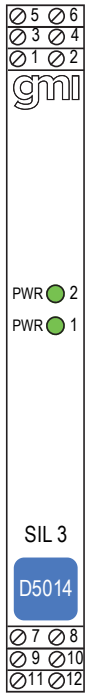

- SIL 3 according to IEC 61508:2010 Ed.2 for Tproof = 1 / 10 yrs (≤10% / >10 % of total SIF).
- SIL 2 according to IEC 61508:2010 Ed.2 for Tproof = 14 / 20 yrs (≤10% / >10 % of total SIF).
- PFDavg (1 year) 6.69 E-05, SFF 90.47 %.
- Systematic capability SIL 3
- 2 fully independent channels.
- Input from Zone 0 (Zone 20), installation in Zone 2.
- 4-20 mA Input / Output Signal Active-Passive / Source-Sink
- Hart compatible.
- Input and Output short circuit proof.
- High Accuracy.
- Three port isolation, Input/Output/Supply.
- EMC Compatibility to EN61000-6-2, EN61000-6-4, EN61326-1, EN61326-3-1 for safety system.
- In-field programmability by DIP Switch.
- ATEX, IECEx, UL & C-UL, FM, FMC, INMETRO, EAC-EX, CCC, TIIS, TÜV Certifications.
- Type Approval Certificate DNV and KR for maritime applications.
- TUV Functional Safety Certification.
- High Density, two channels per unit.
- Simplified installation using standard DIN-Rail and plug-in terminal blocks, with or without Power Bus, or customized Termination Boards.
- 250 Vrms (Um) max. voltage allowed to the instruments associated with the barrier.

Terminal block connections

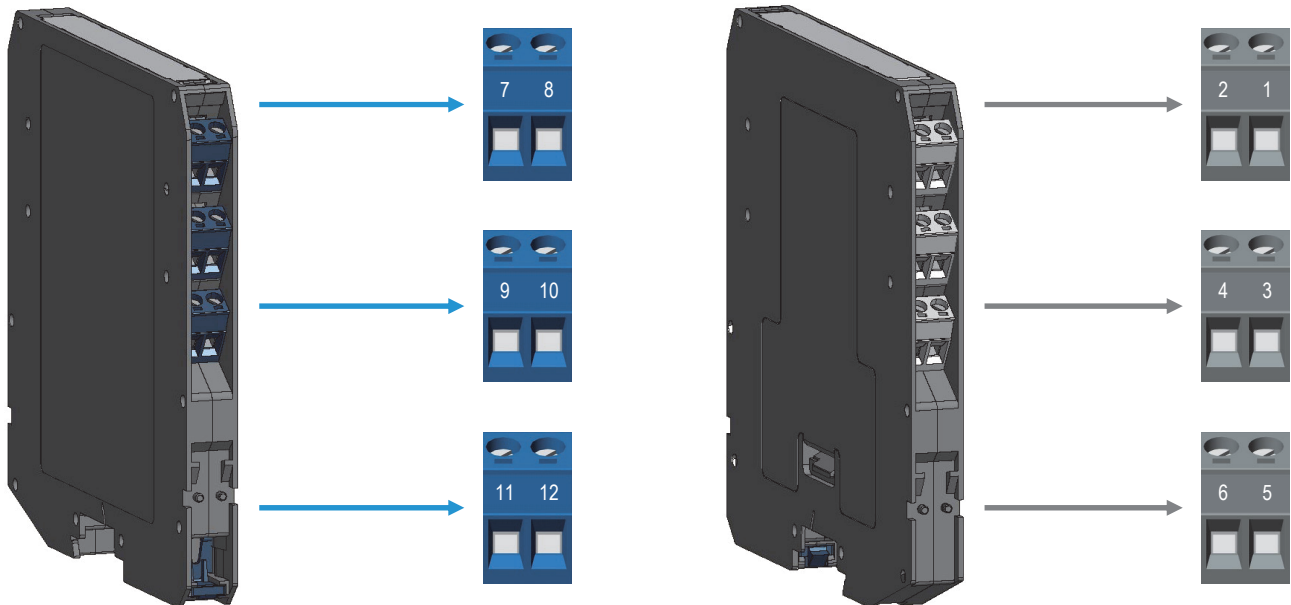

HAZARDOUS AREA

7	+ Input Ch 1 for 2 wires Transmitters
8	- Input Ch 1 for 2 wires Transmitters or + Input Ch 1 for External Powered Transmitters
9	+ Input Ch 2 for 2 wires Transmitters
10	- Input Ch 2 for 2 wires Transmitters or + Input Ch 2 for External Powered Transmitters
11	- Input Ch 1 for External Powered Transmitters
12	- Input Ch 2 for External Powered Transmitters

SAFE AREA

1	+ Output Ch 1
2	- Output Ch 1
3	+ Output Ch 2
4	- Output Ch 2
5	+ Power Supply 24 Vdc
6	- Power Supply 24 Vdc

Parameters Table

In the system safety analysis, always check the Hazardous Area/Hazardous Locations devices to conform with the related system documentation, if the device is Intrinsically Safe check its suitability for the Hazardous Area/Hazardous Locations and group encountered and that its maximum allowable voltage, current, power (U_i/V_{max} , I_i/I_{max} , P_i/P_i) are not exceeded by the safety parameters (U_o/V_{oc} , I_o/I_{sc} , P_o/P_o) of the D5014 series Associated Apparatus connected to it. Also consider the maximum operating temperature of the field device, check that added connecting cable and field device capacitance and inductance do not exceed the limits (C_o/C_a , L_o/L_a , L_o/R_o) given in the Associated Apparatus parameters for the effective group. See parameters indicated in the table below:

D5014 Terminals		D5014 Associated Apparatus Parameters		Must be	Hazardous Area/ Hazardous Locations Device Parameters
Ch1	7 - 8	$U_o / V_{oc} = 25.9 \text{ V}$		\leq	U_i / V_{max}
Ch2	9 - 10				
Ch1	8 - 11	$U_o / V_{oc} = 1.1 \text{ V}$		\leq	U_i / V_{max}
Ch2	10 - 12				
Ch1	7 - 8	$I_o / I_{sc} = 92 \text{ mA}$		\leq	I_i / I_{max}
Ch2	9 - 10				
Ch1	8 - 11	$I_o / I_{sc} = 56 \text{ mA}$		\leq	I_i / I_{max}
Ch2	10 - 12				
Ch1	7 - 8	$P_o / P_o = 594 \text{ mW}$		\leq	P_i / P_i
Ch2	9 - 10				
Ch1	8 - 11	$P_o / P_o = 16 \text{ mW}$		\leq	P_i / P_i
Ch2	10 - 12				
D5014 Terminals		D5014 Associated Apparatus Parameters Cenelec (US)		Must be	Hazardous Area/ Hazardous Locations Device + Cable Parameters
Ch1	7 - 8	$C_o / C_a = 100 \text{ nF}$ $C_o / C_a = 770 \text{ nF}$ $C_o / C_a = 2.63 \text{ }\mu\text{F}$ $C_o / C_a = 4.02 \text{ }\mu\text{F}$ $C_o / C_a = 770 \text{ nF}$	IIC (A, B) IIB (C) IIA (D) I IIIC (E, F, G)	\geq	$C_i / C_i \text{ device} + C \text{ cable}$
Ch2	9 - 10				
Ch1	8 - 11	$C_o / C_a = 100 \text{ }\mu\text{F}$ $C_o / C_a = 1000 \text{ }\mu\text{F}$ $C_o / C_a = 1000 \text{ }\mu\text{F}$ $C_o / C_a = 1000 \text{ }\mu\text{F}$ $C_o / C_a = 1000 \text{ }\mu\text{F}$	IIC (A, B) IIB (C) IIA (D) I IIIC (E, F, G)	\geq	$C_i / C_i \text{ device} + C \text{ cable}$
Ch2	10 - 12				
Ch1	7 - 8	$L_o / L_a = 3 \text{ mH}$ $L_o / L_a = 16.8 \text{ mH}$ $L_o / L_a = 33.7 \text{ mH}$ $L_o / L_a = 55.2 \text{ mH}$ $L_o / L_a = 16.8 \text{ mH}$	IIC (A, B) IIB (C) IIA (D) I IIIC (E, F, G)	\geq	$L_i / L_i \text{ device} + L \text{ cable}$
Ch2	9 - 10				
Ch1	8 - 11	$L_o / L_a = 11.3 \text{ mH}$ $L_o / L_a = 45.3 \text{ mH}$ $L_o / L_a = 90.7 \text{ mH}$ $L_o / L_a = 151.1 \text{ mH}$ $L_o / L_a = 45.3 \text{ mH}$	IIC (A, B) IIB (C) IIA (D) I IIIC (E, F, G)	\geq	$L_i / L_i \text{ device} + L \text{ cable}$
Ch2	10 - 12				
Ch1	7 - 8	$L_o / R_o = 59.9 \text{ }\mu\text{H}/\Omega$ $L_o / R_o = 239.7 \text{ }\mu\text{H}/\Omega$ $L_o / R_o = 479.4 \text{ }\mu\text{H}/\Omega$ $L_o / R_o = 786.6 \text{ }\mu\text{H}/\Omega$ $L_o / R_o = 239.7 \text{ }\mu\text{H}/\Omega$	IIC (A, B) IIB (C) IIA (D) I IIIC (E, F, G)	\geq	$L_i / R_i \text{ device and}$ $L \text{ cable} / R \text{ cable}$
Ch2	9 - 10				
Ch1	8 - 11	$L_o / R_o = 2327.2 \text{ }\mu\text{H}/\Omega$ $L_o / R_o = 9309 \text{ }\mu\text{H}/\Omega$ $L_o / R_o = 18618.1 \text{ }\mu\text{H}/\Omega$ $L_o / R_o = 30545.4 \text{ }\mu\text{H}/\Omega$ $L_o / R_o = 9309 \text{ }\mu\text{H}/\Omega$	IIC (A, B) IIB (C) IIA (D) I IIIC (E, F, G)	\geq	$L_i / R_i \text{ device and}$ $L \text{ cable} / R \text{ cable}$
Ch2	10 - 12				

When used with separate powered intrinsically safe devices, check that maximum allowable voltage, current (U_i/V_{max} , I_i/I_{max}) of the D5014 Associated Apparatus are not exceeded by the safety parameters (U_o/V_{oc} , I_o/I_{sc}) of the Intrinsically Safe device, indicated in the table below:

D5014 Terminals		D5014 Associated Apparatus Parameters	Must be	Hazardous Area/ Hazardous Locations Device Parameters
Ch1	8 - 11	$U_i / V_{max} = 30 \text{ V}$	\geq	U_o / V_{oc}
Ch2	10 - 12			
Ch1	8 - 11	$I_i / I_{max} = 128 \text{ mA}$	\geq	I_o / I_{sc}
Ch2	10 - 12			
Ch1	8 - 11	$C_i = 0 \text{ nF}$, $L_i = 0 \text{ nH}$		
Ch2	10 - 12			

For installations in which both the C_i and L_i of the Intrinsically Safe apparatus exceed 1% of the C_o and L_o parameters of the Associated Apparatus (excluding the cable), then 50% of C_o and L_o parameters are applicable and shall not be exceeded (50% of the C_o and L_o become the limits which must include the cable such that C_i device + C cable \leq 50 % of C_o and L_i device + L cable \leq 50 % of L_o). The reduced capacitance of the external circuit (including cable) shall not be greater than 1 μF for Groups I, IIA, IIB and 600 nF for Group IIC. If the cable parameters are unknown, the following value may be used: Capacitance 200 pF per meter (60 pF per foot), Inductance 1 μH per meter (0.20 μH per foot).

Function Diagram

HAZARDOUS AREA ZONE 0 (ZONE 20) GROUP IIC,
HAZARDOUS LOCATIONS CLASS I, DIVISION 1, GROUPS A, B, C, D,
CLASS II, DIVISION 1, GROUPS E, F, G, CLASS III, DIVISION 1,
CLASS I, ZONE 0, GROUP IIC

SAFE AREA, ZONE 2 GROUP IIC T4,
NON HAZARDOUS LOCATIONS, CLASS I, DIVISION 2,
GROUPS A, B, C, D T-Code T4, CLASS I, ZONE 2, GROUP IIC T4

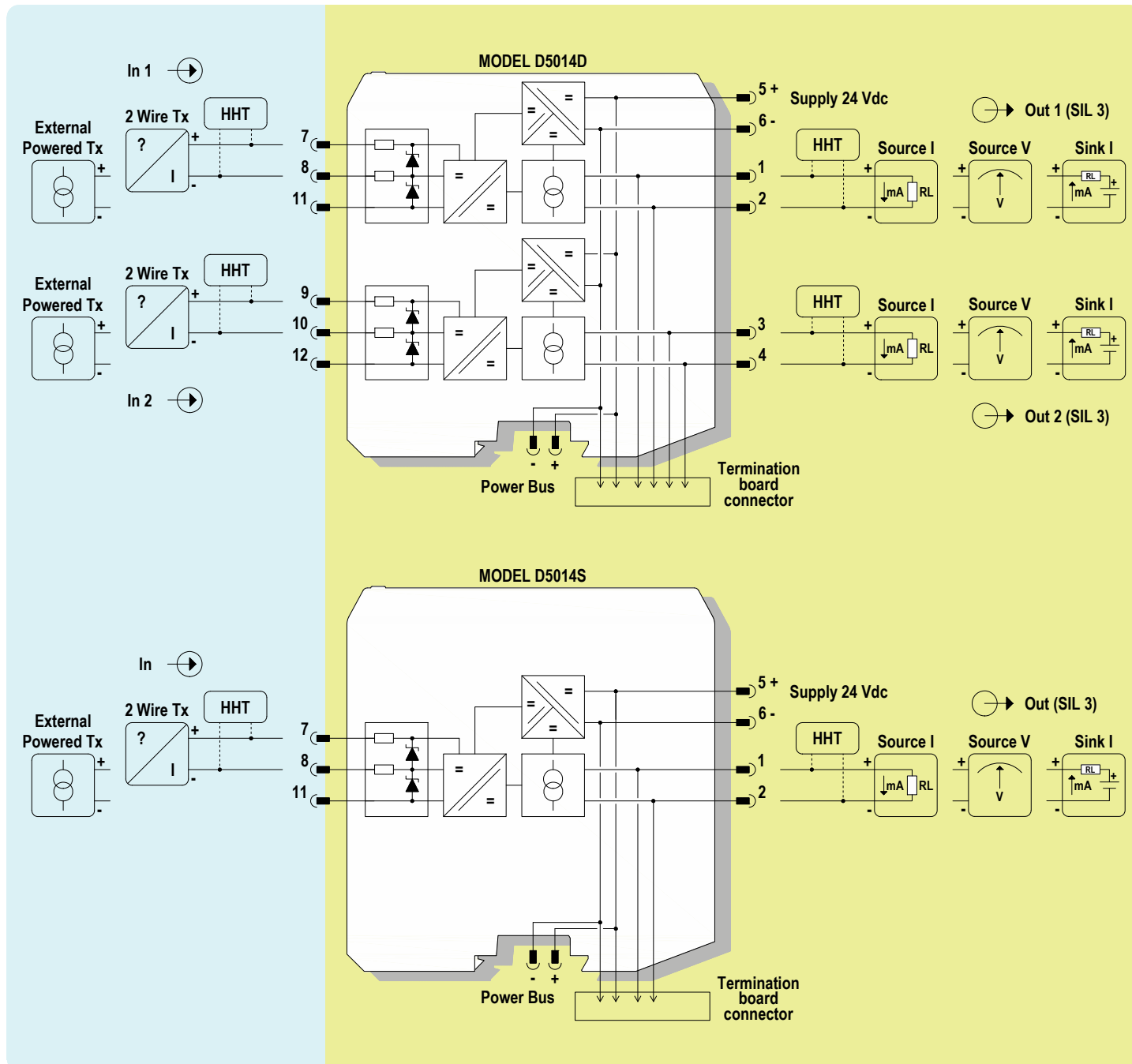

HAZARDOUS AREA ZONE 0 (ZONE 20) GROUP IIC

SAFE AREA, ZONE 2 GROUP IIC T4

Safety Description

Terminals 7-10
 $U_o/V_{oc} = 27\text{ V}$
 $I_o/I_{sc} = 93\text{ mA}$
 $P_o/P_o = 623\text{ mW}$

Group Cenelec	Co/Ca (μF)	Lo/La (mH)	Lo/Ro (μH/Ω)
IIC	0.090	3	57.0
IIB	0.705	16.6	228.3
IIA	2.330	33.2	456.6
I	3.750	54.5	749.1
iaD	0.705	16.6	228.3

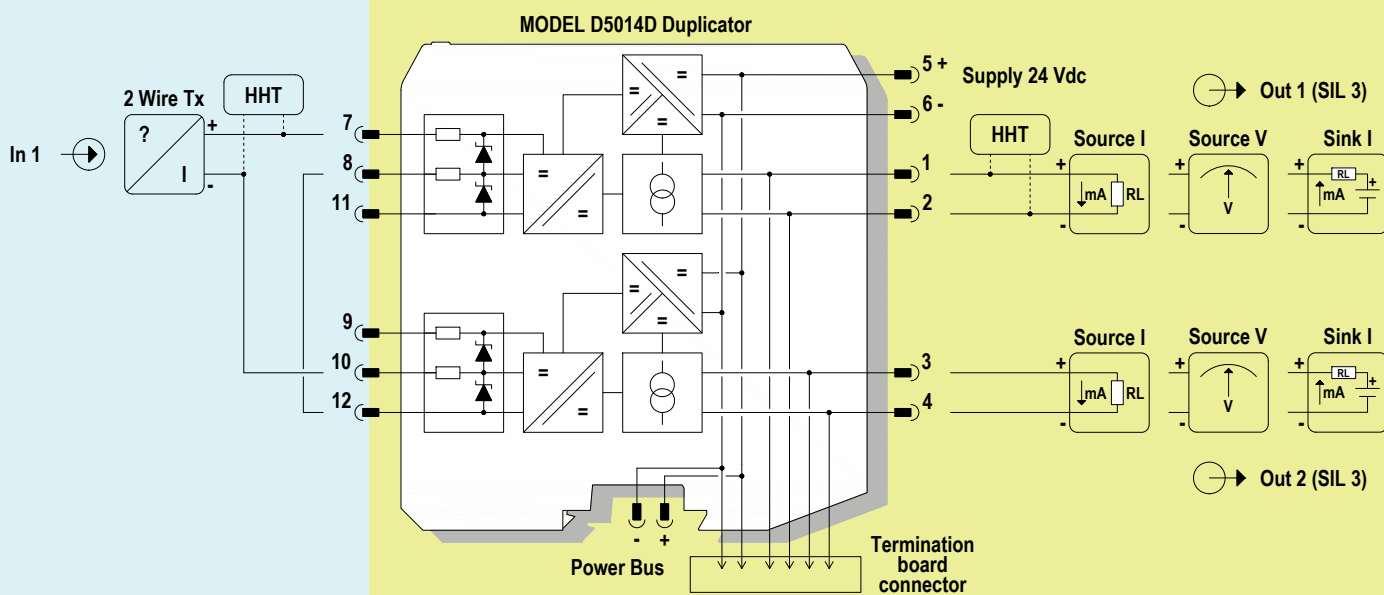

Connections for Duplication of 2 wires Transmitter Input

Restriction on specifications for 2 wires Transmitter Input:
 Bidirectional communication for Smart Transmitter is provided only on channel 1
 The minimum supply voltage available for Transmitter (Vtx) is 14 V at 20 mA input
 The safety parameters must be changed in: $U_o/V_{oc} = 27\text{ V}$, $I_o/I_{sc} = 93\text{ mA}$, $P_o/P_o = 623\text{ mW}$

HAZARDOUS AREA ZONE 0 (ZONE 20) GROUP IIC

SAFE AREA, ZONE 2 GROUP IIC T4

Safety Description

Terminals 8-12
 $U_o/V_{oc} = 2.2\text{ V}$
 $I_o/I_{sc} = 56\text{ mA}$
 $P_o/P_o = 31\text{ mW}$

Group	Co/Ca (μF)	Lo/La (mH)	Lo/Ro ($\mu\text{H}/\Omega$)
Cenelec			
IIC	100	11.3	1163.6
IIB	1000	45.3	4654.5
IIA	1000	90.7	9309
I	1000	151.1	15272.7
iaD	1000	45.3	4654.5

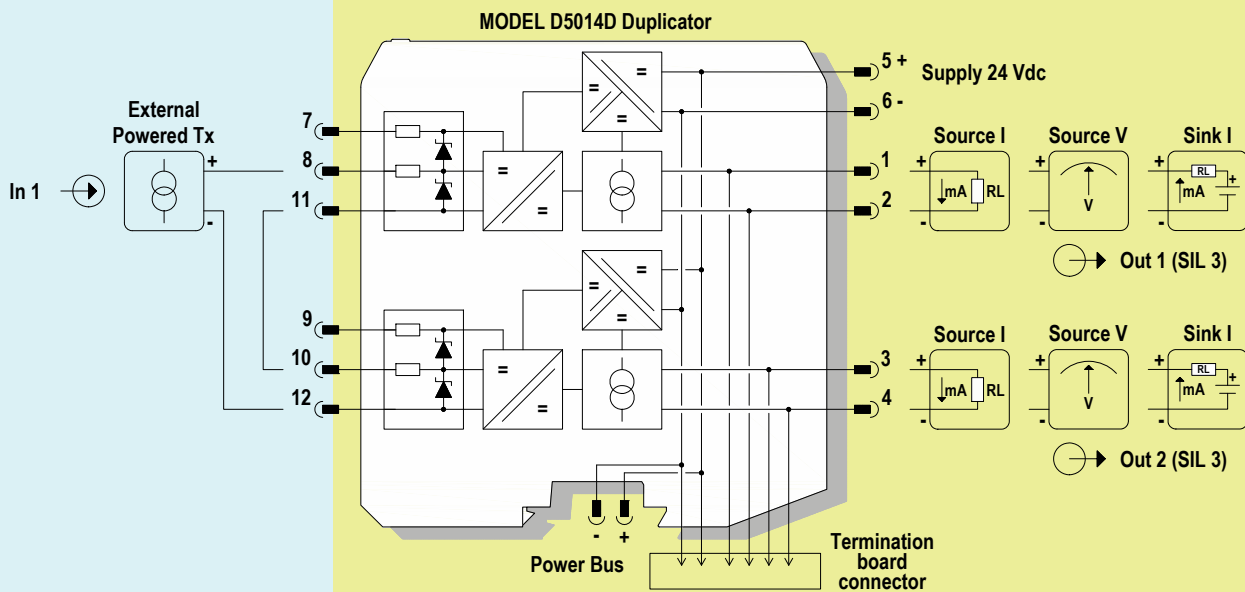

Connections for Duplication of Active Input Signal

Restriction on specifications for external powered Transmitter:
 Voltage drop $\leq 1.0\text{ V}$

The safety parameters must be changed in: $U_o/V_{oc} = 2.2\text{ V}$, $I_o/I_{sc} = 56\text{ mA}$, $P_o/P_o = 31\text{ mW}$

Warning

D5014 series are isolated Intrinsically Safe Associated Apparatus installed into standard EN/IEC60715 TH 35 DIN-Rail located in Safe Area or Zone 2, Group IIC, Temperature T4, Hazardous Area within the specified operating temperature limits Tamb -40 to +70 °C, and connected to equipment with a maximum limit for AC power supply Um of 250 Vrms. Not to be connected to control equipment that uses or generates more than 250 Vrms or Vdc with respect to earth ground.

D5014 series must be installed, operated and maintained only by qualified personnel, in accordance to the relevant national/international installation standards (e.g. IEC/EN60079-14 Electrical apparatus for explosive gas atmospheres - Part 14: Electrical installations in hazardous areas (other than mines)), following the established installation rules, particular care shall be given to segregation and clear identification of I.S. conductors from non I.S. ones.

De-energize power source (turn off power supply voltage) before plug or unplug the terminal blocks when installed in Hazardous Area or unless area is known to be nonhazardous.

Warning: substitution of components may impair Intrinsic Safety and suitability for Zone 2.

Explosion Hazard: to prevent ignition of flammable or combustible atmospheres, disconnect power before servicing or unless area is known to be nonhazardous.

Failure to properly installation or use of the equipment may risk to damage the unit or severe personal injury.

The unit cannot be repaired by the end user and must be returned to the manufacturer or his authorized representative.

Any unauthorized modification must be avoided.

Operation

D5014 provides fully floating DC supply for energizing 2 wires 4-20 mA transmitters, or separately powered 4 wires, 4-20 mA transmitters located in Hazardous Area, and repeats and converts the current to a 4-20 mA or 1-5 V floating output signal to drive a Safe Area load.

The circuit allows bi-directional communication signal for smart transmitters, a "POWER ON" green led for each channel lits when input power is present.

Installation

D5014 series are repeater power supply hart compatible housed in a plastic enclosure suitable for installation on EN/IEC60715 TH 35 DIN-Rail, with or without Power Bus or on customized Termination Board.

D5014 series can be mounted with any orientation over the entire ambient temperature range.

Electrical connection are accommodated by polarized plug-in removable screw terminal blocks which can be plugged in/out into a powered unit without suffering or causing any damage **(for Zone 2 installations check the area to be nonhazardous before servicing)**. Connect only one individual conductor per each clamping point, use conductors up to 2.5 mm² (13 AWG) and a torque value of 0.5-0.6 Nm. The wiring cables have to be proportionate in base to the current and the length of the cable.

In case of installation in zone 2, the connecting cables of non-intrinsically safe circuits must be safely routed in a cable duct or similar. The distance between the pluggable connection terminal and the cable duct should not exceed 500 mm cable length.

On the section "Function Diagram" and enclosure side a block diagram identifies all connections.

Identify the number of channels of the specific card (e.g. D5014S is a single channel model and D5014D is a dual channel model), the function and location of each connection terminal using the wiring diagram on the corresponding section, as an example:

Connect 24 Vdc power supply positive at terminal "5" and negative at terminal "6".

For Model D5014S connect positive output of channel 1 at terminal "1" and negative output at "2".

For Model D5014D in addition to channel 1 connections above, connect positive output of channel 2 at terminal "3" and negative output at "4".

For Model D5014S, in case of a 2 wires Transmitter, connect the wires at terminal "7" for positive and "8" for negative.

For separately powered Transmitters connect input signal at terminal "8" for positive and "11" for negative.

For Model D5014D in addition to channel 1 connections above, connect terminal "9" for positive and "10" for negative on channel 2.

Connect input signal from separately powered Transmitters at terminals "10" for positive and "12" for negative on channel 2.

Intrinsically Safe conductors must be identified and segregated from non I.S. and wired in accordance to the relevant national/international installation standards (e.g. EN/IEC60079-14 Electrical apparatus for explosive gas atmospheres - Part 14: Electrical installations in hazardous areas (other than mines)), make sure that conductors are well isolated from each other and do not produce any unintentional connection.

The enclosure provides, according to EN60529, an IP20 minimum degree of protection (or similar to NEMA Standard 250 type 1). The equipment shall only be used in an area of at least pollution degree 2, as defined in IEC 60664-1. When installed in EU Zone 2, the unit shall be installed in an enclosure that provides a minimum ingress protection of IP54 in accordance with IEC 60079-0. When installed in a Class I, Zone 2 Hazardous Location, the unit shall be mounted in a supplemental AEx or Ex enclosure that provides a degree of protection not less than IP54 in accordance with UL/CSA 60079-0. When installed in a Class I, Division 2 Hazardous Location, the unit shall be mounted in a supplemental enclosure that provides a degree of protection not less than IP54. The enclosure must have a door or cover accessible only by the use of a tool. The end user is responsible to ensure that the operating temperature of the module is not exceeded in the end use application.

Units must be protected against dirt, dust, extreme mechanical (e.g. vibration, impact and shock) and thermal stress, and casual contacts. If enclosure needs to be cleaned use only a cloth lightly moistened by a mixture of detergent in water.

Electrostatic Hazard: to avoid electrostatic hazard, the enclosure of D5014 series must be cleaned only with a damp or antistatic cloth.

Any penetration of cleaning liquid must be avoided to prevent damage to the unit. Any unauthorized modification must be avoided.

D5014 series must be connected to SELV or PELV supplies.

All circuits connected to D5014 series must comply with the overvoltage category II (or better) according to EN/IEC60664-1.

Start-up

Before powering the unit check that all wires are properly connected, particularly supply conductors and their polarity, input and output wires, also check that Intrinsically Safe conductors and cable trays are segregated (no direct contacts with other non I.S. conductors) and identified either by color coding, preferably blue, or by marking.

Check conductors for exposed wires that could touch each other causing dangerous unwanted shorts. Turn on power, the "power on" green leds must be lit, for 2 wires transmitter connection the supply voltage on each channel must be ≥ 14.5 V, output signal should be corresponding to the input from the transmitter. If possible change the transmitter output and check the corresponding Safe Area output.

Configuration

An output configuration DIP Switch is located on component side of pcb. This switch allows the mA (sink or source mode) or Volt operating mode configuration.

D5014D

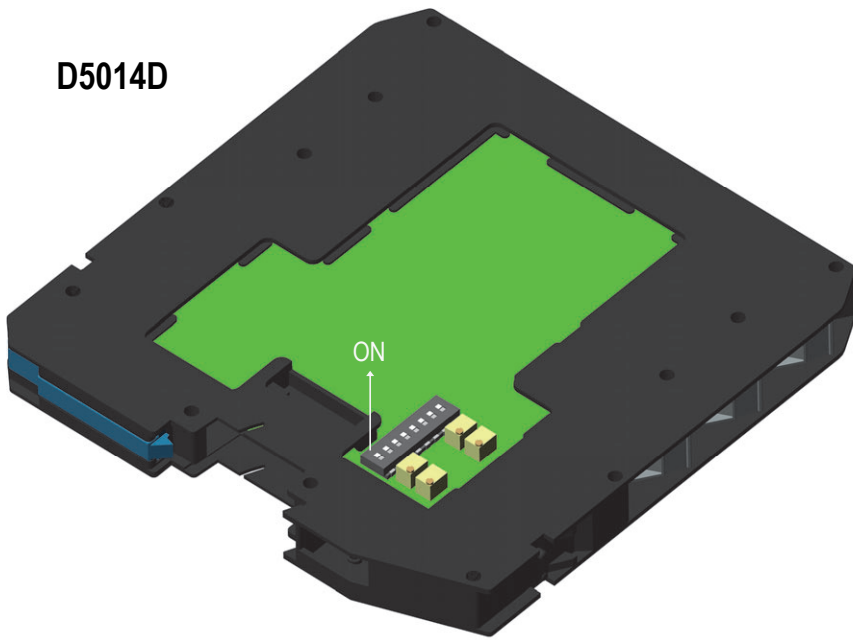

Dip switch configuration

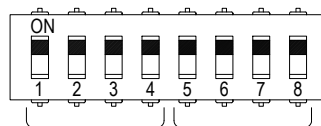

Source mode is factory settings

Only Source/Sink mode can be used for SIL applications.

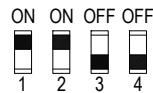

Ch1 4-20 mA
Source Mode



Ch1 4-20 mA
Sink Mode

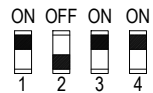

Ch1 1-5 V
(on 250 Ω
internal shunt)

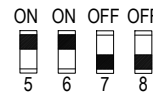

Ch2 4-20 mA
Source Mode

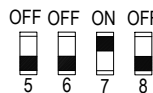

Ch2 4-20 mA
Sink Mode

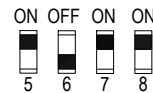

Ch2 1-5 V
(on 250 Ω
internal shunt)

D5014S

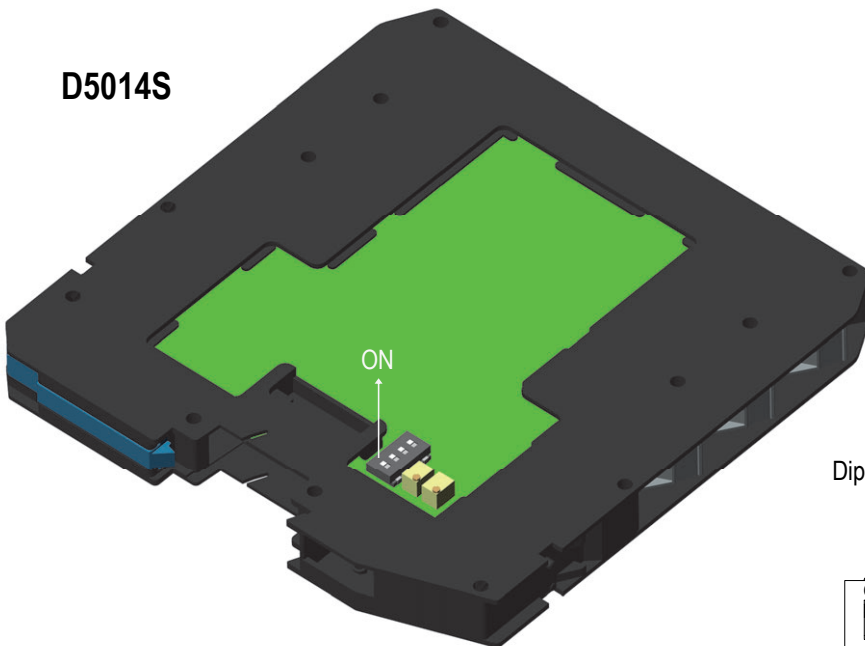

Source mode is factory settings

Only Source/Sink mode can be used for SIL applications.

Dip switch configuration

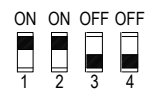
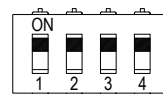

4-20 mA
Source Mode

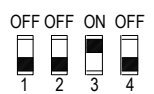

4-20 mA
Sink Mode

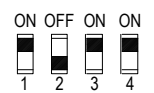

1-5 V (on 250 Ω
internal shunt)