

JUMO MIDAS S21 Ex



Betriebsanleitung
Operating Manual
Notice de mise en service

40471000T90Z000K000

V7.01/DE-EN-FR/00519615/2024-05-15



JUMO MIDAS S21 Ex

Druckmessumformer für den Einsatz im Ex-Bereich



Betriebsanleitung

40471000T90Z000K000

DE/2024-05-15



Weitere Informationen und Downloads



qr-404710-de.jumo.info

| | | |
|----------|--|-----------|
| 1 | Sicherheitshinweise | 4 |
| 1.1 | Warnende Zeichen | 4 |
| 1.2 | Hinweisende Zeichen | 4 |
| 1.3 | Hybride Gemische | 4 |
| 2 | Einleitung | 5 |
| 3 | Geräteausführung identifizieren | 7 |
| 3.1 | Typenschild | 7 |
| 3.2 | Bestellangaben | 7 |
| 3.3 | Lieferumfang | 9 |
| 3.4 | Zubehör | 9 |
| 4 | Technische Daten | 10 |
| 4.1 | Allgemein | 10 |
| 4.2 | Eingang | 10 |
| 4.2.1 | Messbereich und Genauigkeit | 10 |
| 4.3 | Ausgang | 11 |
| 4.4 | Mechanische Eigenschaften | 11 |
| 4.5 | Umwelteinflüsse | 12 |
| 4.6 | Elektrische Daten | 12 |
| 4.7 | Zulassungen und Prüfzeichen | 13 |
| 5 | Montage | 14 |
| 5.1 | Allgemeines | 14 |
| 5.2 | Druckanschluss | 15 |
| 5.3 | Abmessungen | 16 |
| 5.3.1 | Elektrischer Anschluss | 16 |
| 5.3.2 | Prozessanschlüsse | 18 |
| 6 | Installation | 20 |
| 6.1 | Elektrischer Anschluss | 20 |
| 6.2 | Anschlussplan | 21 |
| 6.3 | Anschlussbeispiel | 21 |
| 7 | Wartung, Reinigung, Rücksendung, Entsorgung | 22 |
| 7.1 | Wartung | 22 |
| 7.2 | Reinigung | 22 |
| 7.3 | Rücksendung | 22 |
| 7.4 | Entsorgung | 22 |
| 8 | Zertifikate | 23 |

1 Sicherheitshinweise

1.1 Warnende Zeichen



GEFAHR!

Dieses Zeichen weist darauf hin, dass ein **Personenschaden durch Stromschlag** eintreten kann, wenn die entsprechenden Vorsichtsmaßnahmen nicht getroffen werden.



WARNUNG!

Dieses Zeichen in Verbindung mit dem Signalwort weist darauf hin, dass ein **Personenschaden** eintreten kann, wenn die entsprechenden Vorsichtsmaßnahmen nicht getroffen werden.



VORSICHT!

Dieses Zeichen in Verbindung mit dem Signalwort weist darauf hin, dass ein **Sachschaden oder ein Datenverlust** auftritt, wenn die entsprechenden Vorsichtsmaßnahmen nicht getroffen werden.



VORSICHT!

Dieses Zeichen weist darauf hin, dass durch elektrostatische Entladungen (ESD = Electro Static Discharge) **Bauteile zerstört werden** können, wenn die entsprechenden Vorsichtsmaßnahmen nicht getroffen werden.

Bei Rücksendungen von Geräteeinschüben, Baugruppen oder Bauelementen nur dafür vorgesehene ESD-Verpackungen verwenden.



DOKUMENTATION LESEN!

Dieses Zeichen – angebracht auf dem Gerät – weist darauf hin, dass die zugehörige **Gerätedokumentation** zu **beachten** ist. Dies ist erforderlich, um die Art der potenziellen Gefährdung zu erkennen und Maßnahmen zu deren Vermeidung zu ergreifen.

1.2 Hinweisende Zeichen



HINWEIS!

Dieses Zeichen weist auf eine **wichtige Information** über das Produkt oder dessen Handhabung oder Zusatznutzen hin.



VERWEIS!

Dieses Zeichen weist auf **weitere Informationen** in anderen Abschnitten, Kapiteln oder anderen Anleitungen hin.

1.3 Hybride Gemische

Hybride Gemische sind explosionsfähige Gemische aus brennbaren Gasen, Dämpfen oder Nebeln mit brennbaren Stäuben. Betriebsmittel für explosionsgefährdete Bereiche, in denen hybride Gemische vorhanden sind, müssen für diesen Einsatz besonders geprüft sein. Die Überprüfung der Eignung des Betriebsmittels für solche Einsätze liegt in der Verantwortung des Betreibers.



GEFAHR!

Die Konformitätserklärung, die Baumusterprüfbescheinigung (jeweils am Ende dieser Betriebsanleitung) sowie entsprechende Vorschriften für Sensoren und Versorgungsgeräte in explosionsgefährdeten Bereichen sind zu beachten!

Entsprechend der Ausführung dürfen die Sensoren nur an eigensicheren Stromkreisen betrieben werden.

- ▶ Die zulässigen Werte sind der Bescheinigung zu entnehmen.

Allgemeines

Der Druckmessumformer misst den Druck von Gasen, Dämpfen, Flüssigkeiten. Das Gerät arbeitet nach dem piezoresistiven Messprinzip. Das Ausgangssignal ist ein eingprägter Gleichstrom, der zum Eingangsdruck linear proportional ist.

Der Druckmessumformer Typ 404710 erfüllt die Anforderungen

- der Gerätegruppe II im explosionsgefährdeten Bereich der Zone 1 und 2
- der Gerätegruppe III im explosionsgefährdeten Bereich der Zone 21 und 22

Die EG-Baumusterprüfbescheinigung des Druckmessumformers lautet:

SEV 09 ATEX 0101 X



VORSICHT!

Die Membran des Druckmessumformers darf nicht beschädigt werden!

Folgende Maßnahmen sind zu beachten:

- Keine Gegenstände in die Bohrung des Druckanschlusses einführen!
- Keinen Druckstrahl auf die Membran richten!
- Die Membran darf nicht deformiert werden. Schon das Berühren der Membran mit den Fingern kann diese unter Umständen beschädigen.
- Der zu messende Druck darf auch in Druckspitzen den zulässigen Überdruck des Druckmessumformers nicht überschreiten. Sehr hohe Druckspitzen (Wasserhammer) können den Druckmessumformer zerstören. Bei diesen Bedingungen sind geeignete Vorkehrungen (z. B. der Einbau eines Dämpfungselementes) zu treffen.

2 Einleitung

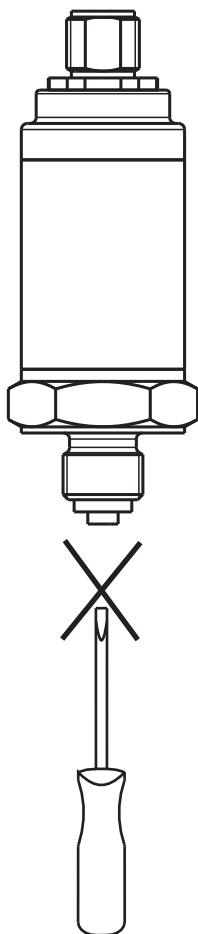

VORSICHT!

Um Beschädigungen am Druckmessumformer zu vermeiden und den Prozess zu sichern, dürfen Montage, Installation und Inbetriebnahme ausschließlich durch qualifiziertes Fachpersonal erfolgen. Dieses muss mit den landesspezifischen Vorschriften vertraut sein und anwendungsorientierte Normen und Richtlinien kennen, um Körper- und Sachschäden zu vermeiden.

- ▶ Das Fachpersonal muss die Betriebsanleitung gelesen, das Typenschild beachtet und beides verstanden haben, so dass es die Anweisungen befolgen kann. Veränderungen und Reparaturen dürfen nur vorgenommen werden, wenn die Betriebsanleitung es zulässt.
Bewahren Sie die Betriebsanleitung an einem für alle Anwender jederzeit zugänglichen Ort auf.
-

3 Geräteausführung identifizieren

3.1 Typenschild

Beispiel:

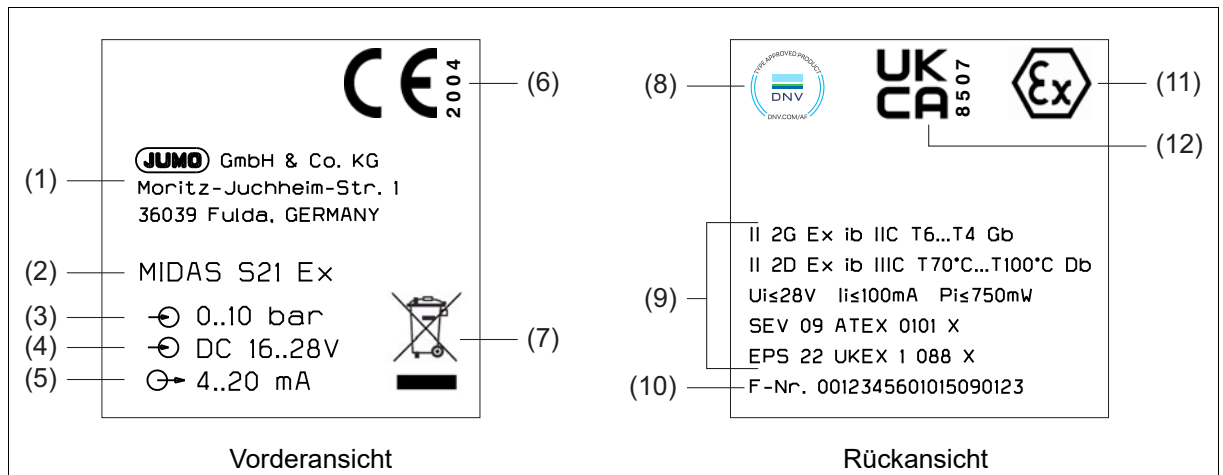

- | | | | |
|---|--------------------------|----|--------------------|
| 1 | Hersteller und Anschrift | 7 | Entsorgung |
| 2 | Gerätebezeichnung | 8 | DNV-Kennzeichnung |
| 3 | Messbereich | 9 | Ex-Angaben |
| 4 | Spannungsversorgung | 10 | Fabrikationsnummer |
| 5 | Ausgang | 11 | Ex-Kennzeichnung |
| 6 | CE-Kennzeichnung | 12 | UKCA-Kennzeichnung |

3.2 Bestellangaben

| (1) Grundtyp | |
|-----------------------------|---|
| 404710/000 | JUMO MIDAS S21 Ex – Druckmessumformer für den Einsatz im Ex-Bereich |
| (2) Eingang Nennmessbereich | |
| 451 | 0 bis 0,25 bar Relativdruck |
| 452 | 0 bis 0,4 bar Relativdruck |
| 453 | 0 bis 0,6 bar Relativdruck |
| 454 | 0 bis 1 bar Relativdruck |
| 455 | 0 bis 1,6 bar Relativdruck |
| 456 | 0 bis 2,5 bar Relativdruck |
| 457 | 0 bis 4 bar Relativdruck |
| 458 | 0 bis 6 bar Relativdruck |
| 459 | 0 bis 10 bar Relativdruck |
| 460 | 0 bis 16 bar Relativdruck |
| 461 | 0 bis 25 bar Relativdruck |
| 432 | 0 bis 30 bar Relativdruck |
| 462 | 0 bis 40 bar Relativdruck |
| 463 | 0 bis 60 bar Relativdruck |
| 464 | 0 bis 100 bar Relativdruck |
| 475 | -0,25 bis 0 bar Relativdruck |
| 476 | -0,4 bis 0 bar Relativdruck |
| 477 | -0,6 bis 0 bar Relativdruck |
| 478 | -1 bis 0 bar Relativdruck |

3 Geräteausführung identifizieren

| | |
|-----|--|
| 479 | -1 bis +0,6 bar Relativdruck |
| 480 | -1 bis +1,5 bar Relativdruck |
| 481 | -1 bis +3 bar Relativdruck |
| 482 | -1 bis +5 bar Relativdruck |
| 483 | -1 bis +9 bar Relativdruck |
| 484 | -1 bis +15 bar Relativdruck |
| 485 | -1 bis +24 bar Relativdruck |
| 487 | 0 bis 0,6 bar Absolutdruck |
| 488 | 0 bis 1 bar Absolutdruck |
| 489 | 0 bis 1,6 bar Absolutdruck |
| 490 | 0 bis 2,5 bar Absolutdruck |
| 491 | 0 bis 4 bar Absolutdruck |
| 492 | 0 bis 6 bar Absolutdruck |
| 493 | 0 bis 10 bar Absolutdruck |
| 494 | 0 bis 16 bar Absolutdruck |
| 495 | 0 bis 25 bar Absolutdruck |
| 998 | Sondermessbereich Absolutdruck |
| 999 | Sondermessbereich Relativdruck |
| | (3) Ausgang |
| 405 | 4 bis 20 mA, Zweileiter |
| | (4) Prozessanschluss |
| 502 | G 1/4 DIN EN 837 |
| 503 | G 3/8 DIN EN 837 |
| 504 | G 1/2 DIN EN 837 (Standard) |
| 511 | 1/4-18 NPT DIN EN 837 |
| 512 | 1/2-14 NPT DIN EN 837 |
| 521 | G 1/4 DIN 3852-11 |
| 523 | G 1/2 DIN 3852-11 |
| 563 | 7/16-20 UNF innen mit Ventilkerndrücker |
| 583 | M20 × 1,5 mit Zapfen |
| 999 | Nach Kundenangabe |
| | (5) Werkstoff Prozessanschluss |
| 20 | CrNi (Edelstahl) |
| | (6) Elektrischer Anschluss |
| 11 | Anschlusskabel |
| 24 | Lose Litzen |
| 36 | M12-Steckverbinder |
| 61 | Leitungsdose DIN EN 175301-803 Form A ^a |
| 99 | Sonderausführung |
| | (7) Typenzusätze |
| 085 | UKEX-Zulassung |
| 240 | EAC Ex-Zulassung |
| 462 | Invertes Ausgangssignal |
| 591 | Drossel im Druckkanal |
| 624 | Öl- und fettfrei |
| 630 | Vergrößerter Druckkanal |

3 Geräteausführung identifizieren

880 DNV-Zulassung^b

^a Nur für die Anwendung im Bereich Gas zertifiziert.

^b Nur in Verbindung mit M12-Steckverbinder oder Leitungsdose erhältlich.

| | | | | | | | | | | | | | |
|-------------------------|------------|---|-----|---|-----|---|-----|---|-----|---|-----|---|-----|
| | (1) | - | (2) | - | (3) | - | (4) | - | (5) | - | (6) | / | (7) |
| Bestellschlüssel | | | | | | | | | | | | | |
| Bestellbeispiel | 404710/000 | - | 459 | - | 405 | - | 504 | - | 20 | - | 11 | / | 000 |

3.3 Lieferumfang

| |
|--------------------------------|
| Gerät in bestellter Ausführung |
| Betriebsanleitung |

3.4 Zubehör

Das Zubehör ist nicht nach DNV-Anforderungen geprüft.

| Bezeichnung | Beschreibung | Teile-Nr. |
|--|--|-----------|
| <p>Ex-i Speise- und Eingangstrennverstärker</p>  | <p>Der Ex-i Speise- und Eingangstrennverstärker ist für den Betrieb von im Ex-Bereich installierten eigensicheren (Ex-i)-Messumformern und mA-Stromquellen ausgelegt.</p> <p>Zweileiter-Messumformer werden mit Energie versorgt und analog 0/4 bis 20 mA-Messwerte aus dem Ex-Bereich in den Nicht-Ex-Bereich übertragen. Der Ausgang des Moduls kann aktiv oder passiv betrieben werden. Weitere technische Daten sowie die entsprechenden Sicherheitsbestimmungen sind der Betriebsanleitung B 707530.0 zu entnehmen.</p> | 00577948 |
| <p>Kabeldose, gerade</p>  | <p>Die PVC-Anschlussleitung ist 2 m lang und hat geräte-seitig einen 4-poligen, geraden M12 × 1-Stecker mit vergoldeten Kontakten.</p> | 00404585 |
| <p>Kabeldose, gewinkelt</p>  | <p>Die PVC-Anschlussleitung ist 2 m lang und hat geräte-seitig einen 4-poligen, gewinkelten M12 × 1-Stecker mit vergoldeten Kontakten.</p> | 00409334 |

4 Technische Daten

4.1 Allgemein

| | |
|--|---|
| Referenzbedingungen | gemäß DIN EN 60770-1 und DIN IEC 61298-1 |
| Sensor Material Druckübertragungsmittel zulässige Lastwechsel | Siliziumsensor mit Edelstahlmembran synthetisches Öl > 10 Millionen |
| Montagelage Kalibrationslage | beliebig Gerät senkrecht stehend, Prozessanschluss unten |

4.2 Eingang

4.2.1 Messbereich und Genauigkeit

| Messbereich bar | Linearität ^a % MSP ^f | Genauigkeit bei | | Langzeit- stabilität ^b % MSP pro Jahr | Überlast- barkeit ^c bar | Berst- druck bar |
|-------------------------------------|---|-----------------------------|--------------------------------------|---|--|------------------------|
| | | 20 °C ^d % MSP | -20 bis +85 °C ^e % MSP | | | |
| 0 bis 0,6 bar Relativ-/Absolutdruck | 0,3 | 0,5 | 1,2 | < 0,2 | 2,4 | 6 |
| 0 bis 1 bar Relativ-/Absolutdruck | 0,3 | 0,5 | 1,2 | | 4 | 10 |
| 0 bis 1,6 bar Relativ-/Absolutdruck | 0,3 | 0,4 | 1,0 | | 6,4 | 16 |
| 0 bis 2,5 bar Relativ-/Absolutdruck | 0,3 | 0,4 | 1,0 | | 10 | 25 |
| 0 bis 4 bar Relativ-/Absolutdruck | 0,3 | 0,4 | 1,0 | | 16 | 40 |
| 0 bis 6 bar Relativ-/Absolutdruck | 0,3 | 0,4 | 1,0 | | 24 | 60 |
| 0 bis 10 bar Relativ-/Absolutdruck | 0,3 | 0,4 | 1,0 | | 40 | 100 |
| 0 bis 16 bar Relativ-/Absolutdruck | 0,3 | 0,4 | 1,0 | | 64 | 160 |
| 0 bis 25 bar Relativ-/Absolutdruck | 0,3 | 0,4 | 1,0 | | 100 | 250 |
| 0 bis 30 bar Relativ-/Absolutdruck | 0,3 | 0,4 | 1,0 | | 100 | 250 |
| 0 bis 0,25 bar Relativdruck | 0,3 | 0,5 | 1,2 | | 1 | 2,5 |
| 0 bis 0,4 bar Relativdruck | 0,3 | 0,5 | 1,2 | | 1,6 | 4 |
| 0 bis 40 bar Relativdruck | 0,3 | 0,4 | 1,0 | | 300 | 400 |
| 0 bis 60 bar Relativdruck | 0,3 | 0,4 | 1,0 | | 300 | 400 |
| 0 bis 100 bar Relativdruck | 0,3 | 0,4 | 1,0 | | 300 | 400 |
| -0,25 bis 0 bar Relativdruck | 0,3 | 0,5 | 1,2 | | 1 | 2,5 |
| -0,4 bis 0 bar Relativdruck | 0,3 | 0,5 | 1,2 | | 1,6 | 4 |
| -0,6 bis 0 bar Relativdruck | 0,3 | 0,5 | 1,2 | | 2,4 | 6 |
| -1 bis 0 bar Relativdruck | 0,3 | 0,5 | 1,2 | | 4 | 10 |
| -1 bis +0,6 bar Relativdruck | 0,3 | 0,4 | 1,0 | | 6,4 | 16 |
| -1 bis +1,5 bar Relativdruck | 0,3 | 0,4 | 1,0 | 10 | 25 | |
| -1 bis +3 bar Relativdruck | 0,3 | 0,4 | 1,0 | 16 | 40 | |
| -1 bis +5 bar Relativdruck | 0,3 | 0,4 | 1,0 | 24 | 60 | |
| -1 bis +9 bar Relativdruck | 0,3 | 0,4 | 1,0 | 40 | 100 | |
| -1 bis +15 bar Relativdruck | 0,3 | 0,4 | 1,0 | 64 | 160 | |
| -1 bis +24 bar Relativdruck | 0,3 | 0,4 | 1,0 | 100 | 250 | |

^a Linearität nach Grenzpunkteinstellung

^b Referenzbedingungen EN 61298-1

^c Alle Druckmessumformer sind vakuumfest.

4 Technische Daten

- ^d Beinhaltet: Linearität, Hysterese, Wiederholbarkeit, Abweichung Messbereichsanfangswert (Offset) und Messbereichsendwert
- ^e Beinhaltet: Linearität, Hysterese, Wiederholbarkeit, Abweichung Messbereichsanfangswert (Offset) und Messbereichsendwert, thermischer Einfluss auf Messbereichsanfang (Offset) und Messspanne
- ^f MSP = Messspanne

4.3 Ausgang

| | |
|--|--|
| Ausgangssignal Strom | 4 bis 20 mA, Zweileiter |
| Sprungantwort T ₉₀ | ≤ 2 ms |
| Bürde 4 bis 20 mA, Zweileiter Bürdeneinfluss | $R_B \leq (U_B - 16 \text{ V}) \div 0,022 \text{ A} (\Omega)$ ≤ 0,004 % pro 100 Ω |

4.4 Mechanische Eigenschaften

| | |
|------------------------|----------------------------------|
| Werkstoff | |
| Prozessanschluss | 316 Ti |
| Nach Kundenangabe | 316 L |
| Membran | 316 L |
| Gehäuse | 304 |
| Festes Kabel | Silikon |
| Lose Litzen | Silikon |
| Rundstecker M12 × 1 | PA, Zink Druckguss vernickelt |
| Leitungsdose | |
| Ohne DNV-Zulassung | PA 66 GF, PA6-GF30, EPDM |
| Mit DNV-Zulassung | PBT-GF30, PA, EPDM |
| Elektrischer Anschluss | |
| Sonderausführung | PUR |
| Gewicht | 170 g mit Prozessanschluss G 1/2 |

4 Technische Daten

4.5 Umwelteinflüsse

| | |
|--|--|
| Umgebungstemperatur | Equipment Protection Level Gb Temperaturklasse T4: -40 bis +85 °C T5: -40 bis +70 °C T6: -40 bis +55 °C Equipment Protection Level Db maximal Oberflächentemperatur T100 °C: -40 bis +85 °C T85 °C: -40 bis +70 °C T70 °C: -40 bis +55 °C |
| Mediumtemperatur | -40 bis +85 °C |
| Lagertemperatur | -40 bis +100 °C |
| Schutzart ^a | IP65, nach DIN EN 60529 |
| elektromagnetische Verträglichkeit (EMV) | nach EN 61326-2-3:2022 |
| Störaussendung | Klasse B ^b |
| Störfestigkeit | Industrieanforderung |
| mechanische Beanspruchung | |
| Schockfestigkeit | 100 g/1 ms, nach DIN EN 60068-2-27 |
| Schwingungsfestigkeit | 20 g bei 15 bis 2000 Hz, nach DIN EN 60068-2-6 |

^a Die Schutzart wird nur mit geeignetem, montiertem Gegenstück erreicht. Der Anschlussleitungsdurchmesser bei Leitungsdose ist minimal 4,5 mm, maximal 7 mm.

^b Das Produkt ist für den industriellen Einsatz sowie für Haushalt und Kleingewerbe geeignet.

Für die besonderen Bedingungen zur Verwendung die Baumusterprüfbescheinigung beachten.



4.6 Elektrische Daten

| | |
|---|---|
| Spannungsversorgung U _B ^a | |
| Nennspannung | DC 24 V |
| 4 bis 20 mA | |
| Ohne DNV-Zulassung | DC 16 bis 28 V |
| Mit DNV-Zulassung | DC 21 bis 24 V |
| Stromaufnahme | ≤ 23 mA |
| Stromkreis | Eigensicher |
| Elektrischer Anschluss | |
| Anschlusselemente | Festes Kabel, lose Litzen, Rundstecker M12 ^b , Leitungsdose ^b |

^a Restwelligkeit: Die Spannungsspitzen dürfen die angegebenen Werte der Spannungsversorgung nicht über- bzw. unterschreiten!

^b Mit DNV-Zulassung.

4.7 Zulassungen und Prüfzeichen

| | | |
|---|--|--|
|  | Bezeichnung Prüfstelle Zertifikat-Nr. Prüfgrundlage Gilt für | ATEX Eurofins Electrosuisse Product Testing AG SEV 09 ATEX 0101 X EN 60079-0, EN 60079-11 Typ 404710 |
| | Bezeichnung Prüfstelle Zertifikat-Nr. Prüfgrundlage Gilt für | UKEX Bureau Veritas EPS 22 UKEX 1 088 X EN IEC 60079-0, EN 60079-11 Typ 404710/.../085 |
|  | Bezeichnung Prüfstelle Zertifikat-Nr. Prüfgrundlage Gilt für | DNV DNV TAA0000211 DNV-CG-0339 Typ 404710/...-36/062, Typ 404710/...-61/062 |
|  | Bezeichnung Prüfstelle Zertifikat-Nr. Prüfgrundlage Gilt für | EAC Ex ПрофиТест / ProfiTest RU C-DE.HB07.B.00659/22 TP TC 012/2011 Typ 404710 |

5 Montage



GEFAHR!

Der Druckmessumformer entspricht nicht den Anforderungen „Ausrüstungsteil mit Sicherheitsfunktion“ gemäß Druckgeräte-Richtlinie 2014/68/EU.

- ▶ Bei gefährlichen Messstoffen, z. B. Sauerstoff, Acetylen, brennbaren und giftigen Stoffen, sowie bei Kälteanlagen, Druckbehältern usw. sind die bestehenden einschlägigen Vorschriften zu beachten! Die nationalen und internationalen Sicherheits- und Unfallverhütungsvorschriften müssen beachtet werden!
Nichtbeachten dieser Vorschriften kann Personen- oder Sachschäden verursachen!
Der Anlagenbetreiber ist für die Einhaltung der gesetzlichen Bestimmungen verantwortlich!
Nur entsprechend qualifizierte Personen dürfen an diesem Gerät arbeiten.
-

5.1 Allgemeines

Vor der Montage



GEFAHR!

Vor der Montage des Druckmessumformers ist die Anlage drucklos zu machen!



VORSICHT!

Der Druckmessumformer darf nur für solche Messstoffe verwendet werden, für die die Membran hinreichend chemisch beständig ist (Korrosion).
Eine elektrisch leitende Verbindung zwischen Druckmessumformer und Prozessanschluss (Anlage) muss gewährleistet sein.



HINWEIS!

Die Einbaustelle soll gut zugänglich, möglichst in der Nähe der Messstelle und erschütterungsarm sein. Die zulässige Umgebungstemperatur muss eingehalten werden (mögliche Wärmestrahlung beachten).
Der Druckmessumformer kann oberhalb oder unterhalb der Druckentnahmestelle montiert werden. Die Nennlage des Druckmessumformers ist senkrecht stehend. Nach den Gegebenheiten der Messstelle kann der Druckmessumformer auch in einer anderen Lage montiert werden.



HINWEIS!

Für die besonderen Bedingungen zur Verwendung ist die Baumusterprüfbescheinigung zu beachten, ⇒ Kapitel 8 „Zertifikate“, Seite 23.

5.2 Druckanschluss

Dichtungen



GEFAHR!

Bei der Zündschutzart **Eigensicherheit** muss bei entsprechendem Prozessanschluss eine **Flachdichtung**, z. B. nach **DIN EN 837**, verwendet werden!

- ▶ Nach Herstellen des Druckanschlusses muss dieser auf Dichtheit geprüft werden!
Wenn der Druckmessumformer in eine Gewindebohrung eingeschraubt wird, muss die **volle Länge** des Gewindes des Druckmessumformers im Einsatz sein!
-



HINWEIS!

Das richtige Anzugsmoment ist abhängig von Größe, Werkstoff und Form der verwendeten Dichtung sowie dem Druckanschluss des Druckmessumformers.

5 Montage

5.3 Abmessungen

5.3.1 Elektrischer Anschluss

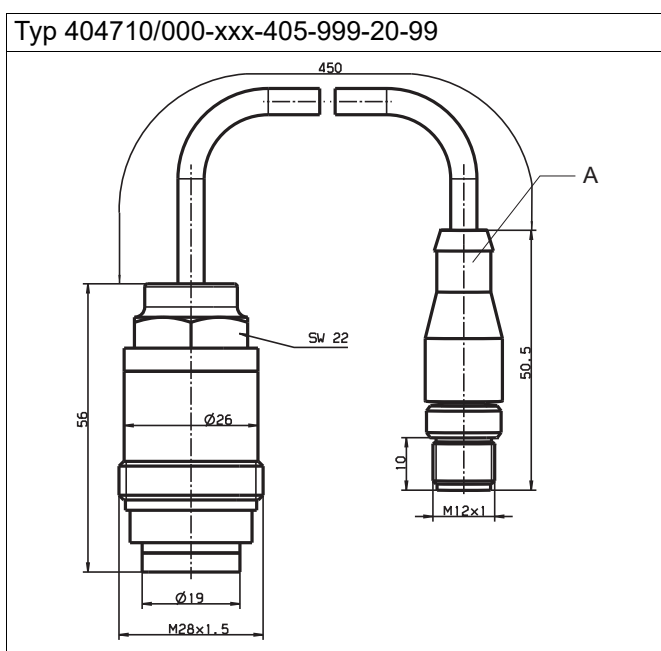
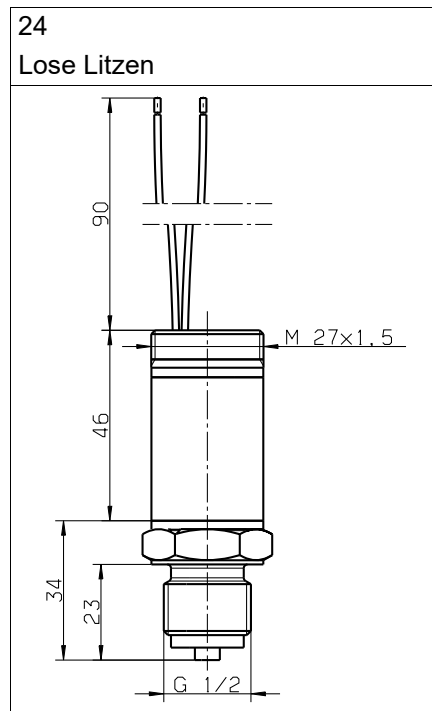
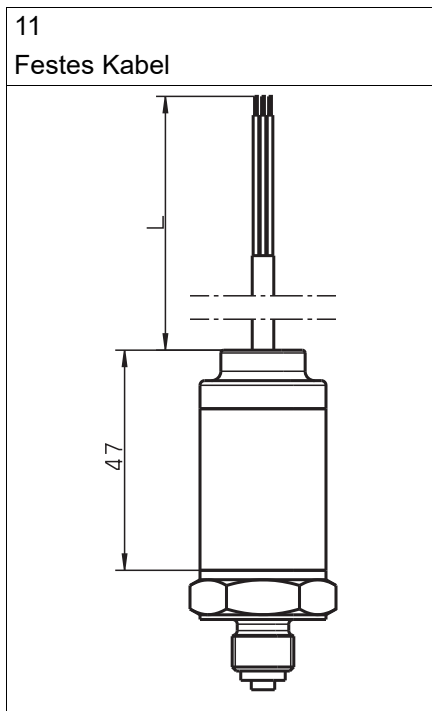

A Kabelstecker 4 × 0,34, 4-polig

Mit DNV-Zulassung

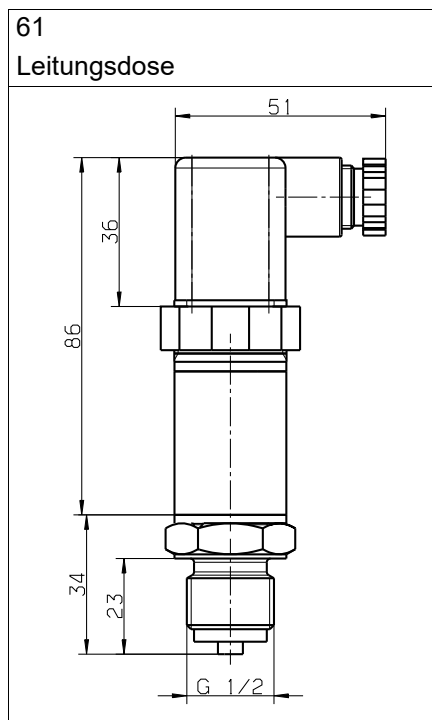
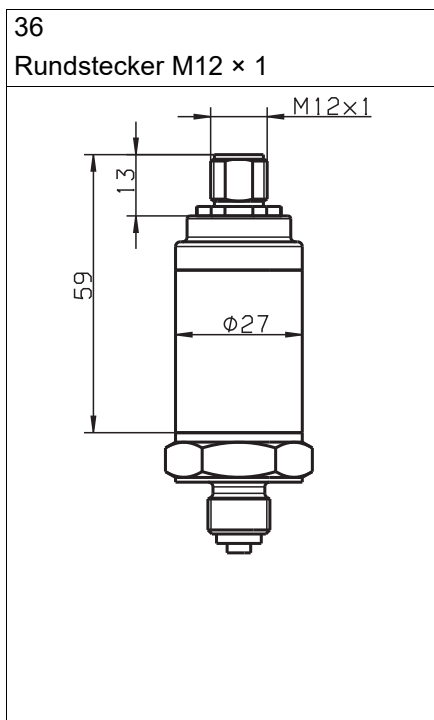

5 Montage

5.3.2 Prozessanschlüsse

Nicht frontbündig

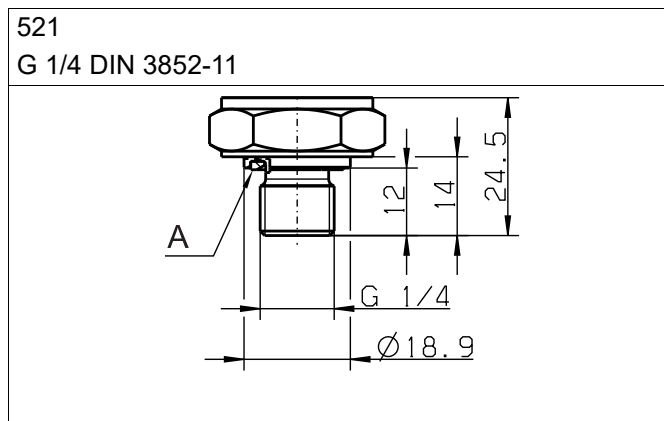
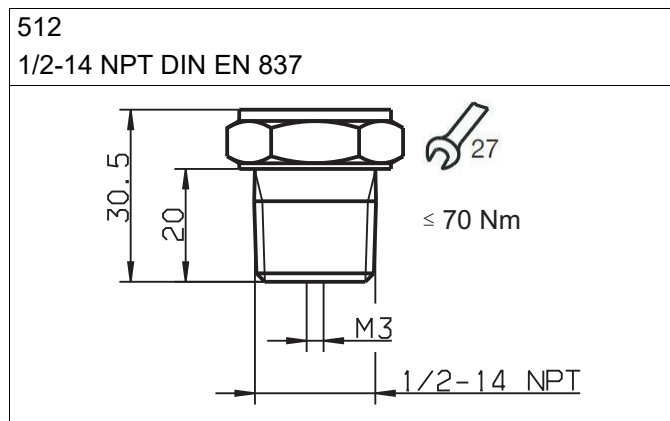
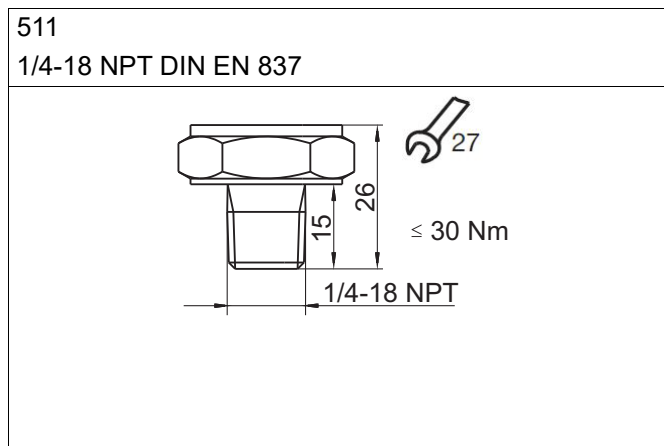
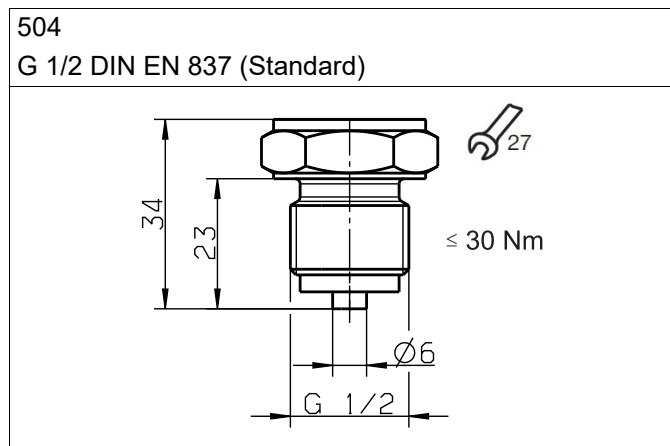
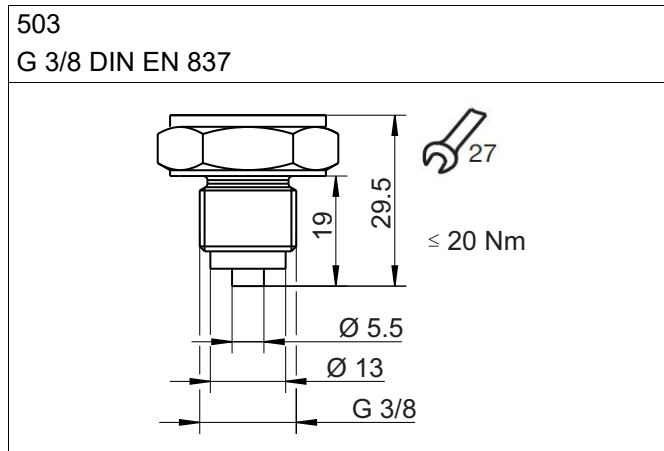
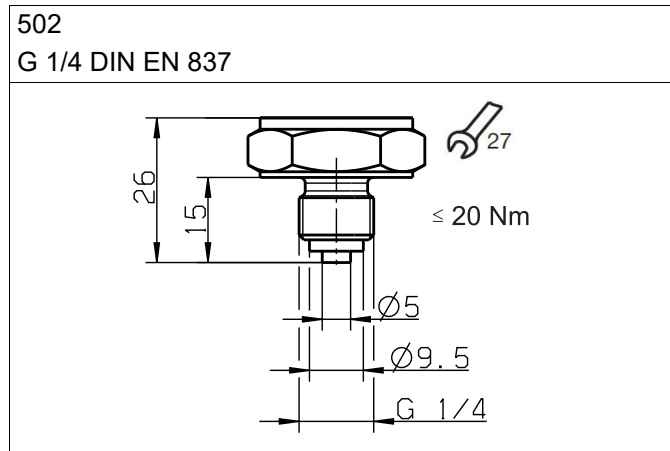

A Profildichtung G 1/4

5 Montage

523
G 1/2 DIN 3852-11

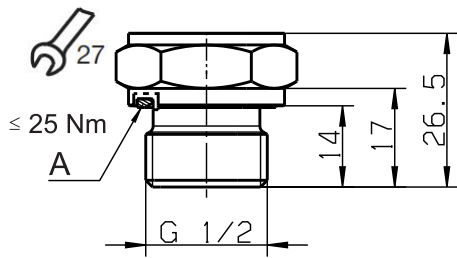

A Profildichtung G 1/2

563
7/16-20 UNF innen mit Ventilkerndrücker

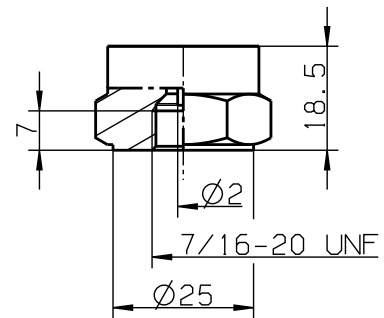

583
M20 × 1,5 mit Zapfen

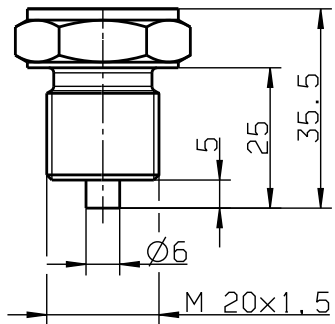

6 Installation

6.1 Elektrischer Anschluss



GEFAHR!

Beim elektrischen Anschluss sind die einschlägigen Bestimmungen zu beachten:

- Verordnung über elektrische Anlagen in explosionsgefährdeten Räumen (Elex V)
- Bestimmung für das Errichten elektrischer Anlagen in explosionsgefährdeten Bereichen
- EG-Baumusterprüfbescheinigung

- ▶ Der elektrische Anschluss darf nur von qualifiziertem Personal durchgeführt werden!
Die Spannungsversorgung muss eigensicher sein und darf folgende Höchstwerte nicht überschreiten:

U_i : DC 28 V

I_i : 100 mA

P_i : 750 mW

wirksame innere Induktivität L: vernachlässigbar klein

wirksame innere Kapazität C: $\leq 10,4$ nF

In eigensicheren Stromkreisen dürfen nur eigensichere, zertifizierte Messgeräte verwendet werden!

Für den elektrischen Anschluss 11 (festes Kabel) ergeben sich in Abhängigkeit von der Kabellänge L folgende Werte:

$$U_i \leq 28 \text{ V}$$

$$I_i \leq 100 \text{ mA}$$

$$P_i \leq 750 \text{ mW}$$

$$C_i \leq 10,4 \text{ nF} + 100 \frac{\text{pF}}{\text{m}} \times L$$

$$L_i \leq 1 \frac{\mu\text{H}}{\text{m}} \times L$$

Allgemeines

- maximale Leitungslänge 50 m
- minimaler Biegeradius 120 mm (bei fester Verlegung)
- das Leitungsende vor Feuchtigkeitseintritt schützen
- bei der Verlängerung der Leitung auf längenabhängige Induktivitäten und Kapazitäten achten
- Signalleitungen getrennt von Kabeln mit Spannungen von > 60 V verlegen
- geschirmte Leitungen mit verdrehten Adern verwenden
- die Nähe von großen elektrischen Anlagen vermeiden



HINWEIS!





Der eigensichere Stromkreis muss auf die Überspannungskategorie I begrenzt werden, wie in IEC 60664-1 festgelegt, und die Speisung der Stromkreise erfolgt ausschließlich aus einer bescheinigten eigensicheren Stromquelle mit einem Schutzniveau „Ib“.



HINWEIS!

Für die besonderen Bedingungen zur Verwendung ist die Baumusterprüfbescheinigung zu beachten, \Rightarrow Kapitel 8 „Zertifikate“, Seite 23.

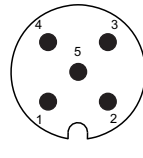
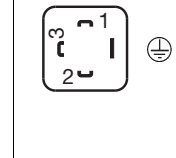
6.2 Anschlussplan

| Anschluss | | Anschlussbelegung (Abbildung: Anschluss am Druckmessumformer) | | | |
|---|---|---|--|---|---|
| | |  |  |  |  |
| | | 11 festes Kabel | 24 lose Litzen | 36 Rundstecker M12 x 1 | 61 Leitungsdose |
| 4 bis 20 mA, Zweileiter (Ausgang 405) | | | | | |
| Spannungsversorgung DC 16 bis 28 V | $U_B/S+$ 0 V/S- | BU BK | BU BK | 1 BN 3 BU | 1 2 |
| Funktionspotenzialausgleichsleiter FB ^a |  | - | - | - | - |

^a Der Druckmessumformer muss mit dem Potenzialausgleichssystem der Anlage über den Prozessanschluss verbunden werden.

| | | |
|---|------|---------|
| Farbbelegung: Anschlussleitung Rundstecker M12 x 1 | 1 BN | Braun |
| | 2 WH | Weiß |
| | 3 BU | Blau |
| | 4 BK | Schwarz |

Die Farbbelegung ist **nur** für A-codierte Standardkabel gültig!



VORSICHT!

Das Gehäuse des Druckmessumformers über den Prozessanschluss – zum Schutz vor elektromagnetischen Feldern und elektromagnetischen Aufladungen – erden (Funktionserdung)!

6.3 Anschlussbeispiel

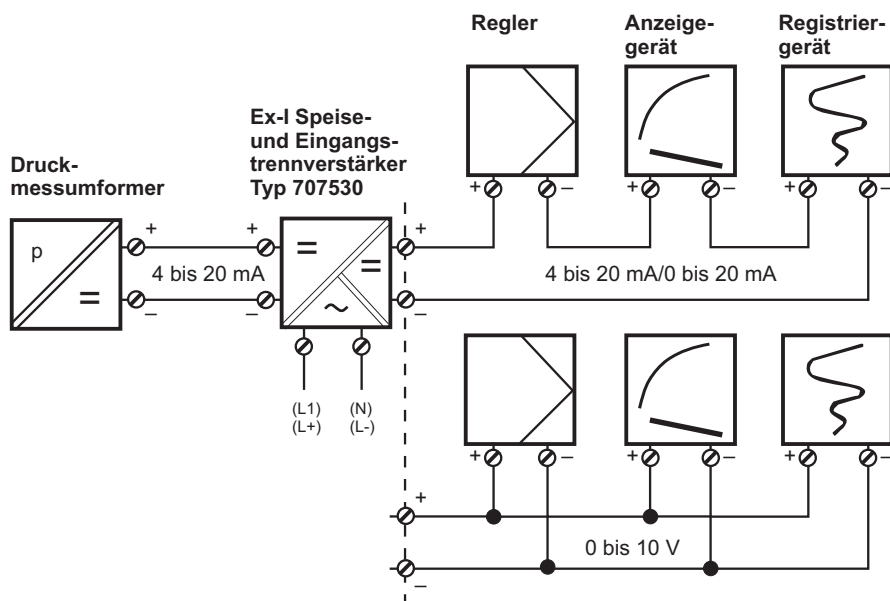

7 Wartung, Reinigung, Rücksendung, Entsorgung

7.1 Wartung

Der Druckmessumformer ist wartungsfrei.

7.2 Reinigung



HINWEIS!

Schaden am Gerät durch unsachgemäße Reinigung vermeiden.

Druckmessumformer, besonders die medienberührten Teile, nicht beschädigen.
Reinigungsmittel darf Oberfläche und Dichtungen nicht angreifen.

7.3 Rücksendung



WARNUNG!

Personenschaden, Sachschaden, Umweltschaden

Messstoffreste am ausgebauten Produkt können Personen, Umwelt und Einrichtungen schädigen.

► Ausreichende Vorsichtsmaßnahmen ergreifen.



HINWEIS!

Alle zur Rücksendung notwendigen Informationen sind im [Begleitschreiben für Produktrücksendungen](#) enthalten.



HINWEIS!

Das Gerät darf nur in einem sicheren, druck- und spannungsfreien Zustand der Anlage durch qualifiziertes Personal demontiert werden.

7.4 Entsorgung



- Das Gerät oder ersetzte Teile nach Beendigung der Nutzung nicht in der Mülltonne entsorgen.
- Auf dem Gerät gespeicherte Programme und Daten löschen.
- Batterien, falls vorhanden, entnehmen, sofern dies ohne Beschädigung des Geräts möglich ist.
- Das Gerät sowie das Verpackungsmaterial ordnungsgemäß und umweltschonend entsorgen lassen.
- Die landesspezifischen Gesetze und Vorschriften zur Abfallbehandlung und Entsorgung beachten.

Gemäß Richtlinie 2012/19/EU über Elektro- und Elektronik-Altgeräte sind Hersteller verpflichtet, die Möglichkeit zur Rücknahme von Altgeräten anzubieten. Die Rückgabe beim Hersteller anfragen.

JUMO GmbH & Co. KGMoritz-Juchheim-Straße 1
36039 Fulda, GermanyTel.: +49 661 6003-0
Fax: +49 661 6003-500E-Mail: mail@jumo.net
Internet: www.jumo.netMore than **sensors + automation**

EU-Konformitätserklärung

EU declaration of conformity / Déclaration UE de conformité

Dokument-Nr. CE 695
Document No. / Document n°.

Hersteller JUMO GmbH & Co. KG
Manufacturer / Etabli par

Anschrift Moritz-Juchheim-Straße 1, 36039 Fulda, Germany
Address / Adresse

Produkt*Product / Produit***Name***Name / Nom***Typ***Type / Type***Typenblatt-Nr.***Data sheet no. / N°**Document**d'identification*

JUMO MIDAS S21 Ex

404710

404710

Produktbeschreibung*Product description / Description du produit*

Industrial pressure transmitter.

Wir erklären in alleiniger Verantwortung, dass das bezeichnete Produkt die Anforderungen der Europäischen Richtlinien erfüllt.

We hereby declare in sole responsibility that the designated product fulfills the requirements of the European Directives.

Nous déclarons sous notre seule responsabilité que le produit remplit les Directives Européennes.

Dokument-Nr.
Document No. / Document n°.

CE 695

EU-Konformitätserklärung

Seite: 1 von 5

8 Zertifikate

JUMO GmbH & Co. KG

Moritz-Juchheim-Straße 1
36039 Fulda, Germany

Tel.: +49 661 6003-0
Fax: +49 661 6003-500

E-Mail: mail@jumo.net
Internet: www.jumo.net



More than sensors + automation

1. Richtlinie

Directive / Directive

Name

EMC 2014/30/EU

Name / Nom

Konformitätsbewertungsverfahren

Mod. A

Conformity assessment procedure /

Procédure d'évaluation de la conformité

Datum der Erstanbringung des CE-Zeichens auf dem Produkt

2009

Date of first application of the CE mark to the product /

Date de 1ère application du sigle sur le produit

Angewendete Normen/Spezifikationen

Standards/Specifications applied / Normes/Spécifications appliquées

Referenz

Reference / Référence

Ausgabe

Edition / Édition

Bemerkung

Comment / Remarque

EN 61326-1

2013

EN 61326-2-3

2013

Gültig für Typ

Valid for Type / Valable pour le type

404710/...

2. Richtlinie

Directive / Directive

Name

ATEX 2014/34/EU

Name / Nom

Konformitätsbewertungsverfahren

Mod. B+D

Conformity assessment procedure /

Procédure d'évaluation de la conformité

Datum der Erstanbringung des CE-Zeichens auf dem Produkt

2009

Date of first application of the CE mark to the product /

Date de 1ère application du sigle sur le produit

Dokument-Nr.

Document No. / Document n°.

CE 695

EU-Konformitätserklärung

Seite: 2 von 5

JUMO GmbH & Co. KG

Moritz-Juchheim-Straße 1
36039 Fulda, Germany

Tel.: +49 661 6003-0
Fax: +49 661 6003-500

E-Mail: mail@jumo.net
Internet: www.jumo.net



More than **sensors + automation**

Angewendete Normen/Spezifikationen

Standards/Specifications applied / Normes/Spécifications appliquées

| Referenz <i>Reference / Référence</i> | Ausgabe <i>Edition / Édition</i> | Bemerkung <i>Comment / Remarque</i> |
|--|-------------------------------------|--|
| EN 60079-0 | 2018 | |
| EN 60079-11 | 2012 | |

Gültig für Typ

Valid for Type / Valable pour le type

404710/000-* -405-* -20-...

2.1 EU-Baumusterprüfbescheinigung

EU type examination certificate / Certificat d'examen de type UE

Zertifikatsnummer SEV 09 ATEX 0101 X Ausgabe 1
Certificate number / Numéro de certificat

Notifizierte Stelle Eurofins Electric & Electronic Product Testing
Notified Body / Organisme notifié AG, Luppmenstrasse 3, 8320 Fehraltdorf,
Switzerland

Angewendete Normen/Spezifikationen

Standards/Specifications applied / Normes/Spécifications appliquées

| Referenz <i>Reference / Référence</i> | Ausgabe <i>Edition / Édition</i> | Bemerkung <i>Comment / Remarque</i> |
|--|-------------------------------------|--|
| EN 60079-0 | 2018 | |
| EN 60079-11 | 2012 | |

Qualitätssicherung bezogen auf den Produktionsprozess

Quality assurance of the production process / L'assurance de la qualité de la production

Zertifikatsnummer Available on request
Certificate number / Numéro de certificat

Notifizierte Stelle BUREAU VERITAS Consumer Products
Notified Body / Organisme notifié Services Germany GmbH, Wilhelm-Hennemann-
Straße 8, 19061 Schwerin, Germany

Kennnummer 2004
Identification no. / N° d'identification

Dokument-Nr.
Document No. / Document n°.

CE 695

EU-Konformitätserklärung

Seite: 3 von 5

8 Zertifikate

JUMO GmbH & Co. KG

Moritz-Juchheim-Straße 1
36039 Fulda, Germany

Tel.: +49 661 6003-0
Fax: +49 661 6003-500

E-Mail: mail@jumo.net
Internet: www.jumo.net



More than **sensors + automation**

3. Richtlinie

Directive / Directive

Name

RoHS 2011/65/EU

Name / Nom

Konformitätsbewertungsverfahren

Mod. A

Conformity assessment procedure /

Procédure d'évaluation de la conformité

Datum der Erstanbringung des CE-Zeichens auf dem Produkt

2017

Date of first application of the CE mark to the product /

Date de 1ère application du sigle sur le produit

Angewendete Normen/Spezifikationen

Standards/Specifications applied / Normes/Spécifications appliquées

Referenz

Reference / Référence

Ausgabe

Edition / Édition

Bemerkung

Comment / Remarque

VDK Umweltrelevante Aspekte V1

bei der Produktentwicklung und
-gestaltung

Gültig für Typ

Valid for Type / Valable pour le type

404710/...

Dokument-Nr.

Document No. / Document n°.

CE 695

EU-Konformitätserklärung

Seite: 4 von 5

JUMO GmbH & Co. KG

Moritz-Juchheim-Straße 1
36039 Fulda, Germany

Tel.: +49 661 6003-0
Fax: +49 661 6003-500

E-Mail: mail@jumo.net
Internet: www.jumo.net



More than **sensors + automation**

Aussteller

Issued by / Etabli par

JUMO GmbH & Co. KG

Ort, Datum

Place, date / Lieu, date

Fulda, 2023-05-10

Rechtsverbindliche Unterschriften

Legally binding signatures /

Signatures juridiquement valable

Bereichsleitung Globaler Vertrieb

i. V. Markus Belmer

Qualitätsbeauftragter und Leiter Qualitätswesen

i. V. Harald Gienger

Dokument-Nr.
Document No. / Document n°.

CE 695

EU-Konformitätserklärung

Seite: 5 von 5



(1) **EU-Baumusterprüfbescheinigung**

- (2) Geräte und Schutzsysteme zur bestimmungsgemässen Verwendung in explosionsgefährdeten Bereichen - Richtlinie 2014/34/EU
- (3) Prüfbescheinigungsnummer: **SEV 09 ATEX 0101 X**
- (4) Produkt: Druckmessumformer
Typ JUMO MIDAS S21 Ex 404710 / 000 - *** - 405 - *** - 20 - **
- (5) Hersteller: JUMO GmbH & Co. KG
- (6) Anschrift: Moritz-Juchheim-Strasse 1, 36039 Fulda, Germany
- (7) Die Bauart dieses Produktes sowie die verschiedenen zulässigen Ausführungen sind in der Anlage zu dieser Prüfbescheinigung festgelegt.
- (8) Eurofins, benannte Stelle Nr. 1258 nach Artikel 17 der Richtlinie 2014/34/EU des Parlaments der europäischen Gemeinschaften und des Rates vom 26. Februar 2014, bescheinigt die Erfüllung der grundlegenden Sicherheits- und Gesundheitsanforderungen für die Konzeption und den Bau von Produkten zur bestimmungsgemässen Verwendung in explosionsgefährdeten Bereichen gemäss Anhang II der Richtlinie.
Die Ergebnisse der Prüfung sind im vertraulichen Prüfbericht 19CH-01050.X02 festgehalten.
- (9) Die grundlegenden Sicherheits- und Gesundheitsanforderungen werden erfüllt durch Übereinstimmung mit:
EN IEC 60079-0:2018
EN 60079-11:2012
- Ausgenommen sind die Bedingungen welche unter Punkt 18 aufgeführt sind.
- (10) Falls «X» hinter der Bescheinigungsnummer steht, wird auf besondere Bedingungen für die sichere Anwendung des Produktes in der Anlage zu dieser Bescheinigung hingewiesen. Falls "U" hinter der Bescheinigungsnummer steht, sind die zertifizierten Geräte oder Schutzsysteme unvollständig. Solche Teilzertifizierungen können als Basis für Geräte- oder Schutzsystem-Zertifizierungen verwendet werden.
- (11) Diese EU-Baumusterprüfbescheinigung bezieht sich nur auf Konzeption und Bau des festgelegten Produktes. Weitere Anforderungen dieser Richtlinie gelten für die Herstellung und das Inverkehrbringen des Produktes, diese sind jedoch nicht Gegenstand dieser Bescheinigung.
- (12) Die Kennzeichnung des Produktes muss die folgenden Angaben enthalten:

 II 2G Ex ib IIC T6 ... T4 Gb
II 2D Ex ib IIIC T70 °C ... T100 °C Db

Eurofins Electric & Electronic Product Testing AG
Notified Body ATEX

Martin Plüss
Produktzertifizierung

www.eurofins.ch

Fehratorf, 2021-04-20

Ausgabe: 1

Page 1 of 4

T8a_V01



(13) **Anlage**(14) **EU-Baumusterprüfbescheinigung SEV 09 ATEX 0101 X**(15) **Beschreibung des Produktes**

Der Druckmessumformer JUMO MIDAS S21 Ex Typ 404710 / 000 - *** - 405 - *** - 20 - ** dient zur Umsetzung einer physikalischen Messgröße (Druck) in ein elektrisches Einheitssignal (Stromsignal 4... 20 mA). Er ist zum Einsatz innerhalb des explosionsgefährdeten Bereichs bestimmt.

Der eigensichere Stromkreis wird mit festem Kabel (Kabellänge im Klartext), Rundstecker M12 x 1 in Kunststoffausführung oder elektrischem Sonderanschluss verbunden.

Typenbezeichnung

Druckmessumformer JUMO MIDAS S21 Ex Typ 404710 / 000 - *** - 405 - *** - 20 - **

Die "*" in der Typenbezeichnung werden durch Kennzeichen von Varianten ersetzt, welche keinen Einfluss auf den Explosionsschutz und die allgemeine Sicherheit haben.

Mess- und Versorgungsstromkreis in Zündschutzart Eigensicherheit

Exib IIC
Ex ib IIIC

Nur zum Anschluss an einen zertifizierten eigensicheren Stromkreis .

Höchstwerte für Rundstecker M12 x 1 und elektrischen Sonderanschluss:

U: s 28 V
Ii s 100 mA
Pis 0.75 W
Ci = 10.4 nF (Wirksame innere Kapazität)
Li "" 0 mH (Wirksame innere Induktivität)

Höchstwerte für den elektrischen Anschluss mit festem Kabel:

U: s 28 V
Ii s 100 mA
Pis 0.75 W
Cis 10.4 nF + 100 pF/m · Kabellänge
Li s 1 µHirn · Kabellänge

Installations- und Gebrauchsart:

Schutzart:

stationär

IP65

Zündschutzart Gb

Umgebungstemperatur:

T4: -40 °C to +85 °C

T5: -40 °C to +70 °C

T6: -40 °C to +55 °C

Umgebungstemperatur (°C):

Zündschutzart Db

Maximale Oberflächentemperatur:

T100 °C: -40 °C to +85 °C

T85 °C: -40 °C to +70 °C

T70 °C: -40 °C to +55 °C

8 Zertifikate



Beispiel für Typbezeichnung 404710/000 - 459 - 405 - 504 - 20 - 11 / 000
(1) (2) (3) (4) (5) (6) (7)

(1) Grundtyp

404710/000 JUMO MIDAS S21 Ex – Druckmessumformer für den Einsatz im Ex-Bereich

(2)* Eingang Nennmessbereich

432 0 bis 30 bar Relativdruck
451 0 bis 0.25 bar Relativdruck
452 0 bis 0.4 bar Relativdruck
453 0 bis 0.6 bar Relativdruck
454 0 bis 1 bar Relativdruck
455 0 bis 1.6 bar Relativdruck
456 0 bis 2.5 bar Relativdruck
457 0 bis 4 bar Relativdruck
458 0 bis 6 bar Relativdruck
459 0 bis 10 bar Relativdruck
460 0 bis 16 bar Relativdruck
461 0 bis 25 bar Relativdruck
462 0 bis 40 bar Relativdruck
463 0 bis 60 bar Relativdruck
464 0 bis 100 bar Relativdruck
475 -0.25 bis 0 bar Relativdruck
476 -0.4 bis 0 bar Relativdruck
477 -0.6 bis 0 bar Relativdruck
478 -1 bis 0 bar Relativdruck
479 -1 bis +0.6 bar Relativdruck
480 -1 bis +1.5 bar Relativdruck
481 -1 bis +3 bar Relativdruck
482 -1 bis +5 bar Relativdruck
483 -1 bis +9 bar Relativdruck
484 -1 bis +15 bar Relativdruck
485 -1 bis +24 bar Relativdruck
487 0 bis 0.6 bar Absolutdruck
488 0 bis 1 bar Absolutdruck
489 0 bis 1.6 bar Absolutdruck
490 0 bis 2.5 bar Absolutdruck
491 0 bis 4 bar Absolutdruck
492 0 bis 6 bar Absolutdruck
493 0 bis 10 bar Absolutdruck
494 0 bis 16 bar Absolutdruck
495 0 bis 25 bar Absolutdruck
998 Sondermessbereich Absolutdruck
999 Sondermessbereich Relativdruck

(3) Ausgang

405 4 bis 20 mA. Zweileiter

(4)* Prozessanschluss

502 G 1/4 nach DIN EN 837
504 G 1/2 nach DIN EN 837
511 1/4-18 NPT nach DIN EN 837
512 1/2-14 NPT nach DIN EN 837
521 G 1/4 nach DIN 3852-11
523 G 1/2 nach DIN 3852-11
563 7/16-20 UNF innen mit Ventilkerndrücker
583 M20 x 1.5 mit Zapfen
999 nach Kundenangabe

(5) Werkstoff Prozessanschluss

20 CrNi (Edelstahl)

(6) elektrischer Anschluss

11 mit festem Kabel
24 Lose Litzen
36 Rundstecker M12x1
61 Leitungsdose DIN EN 175301-803 form A
99 Sonderausführung

(7)* Typenzusätze

000 ohne
462 invertiertes Ausgangssignal
591 Drossel im Druckkanal
624 öl- und fettfrei
630 vergrößerter Druckkanal

*) Die numerischen Typenschlüssel sind durch weitere hier nicht benannte Werte im Sinne der Basisprüfung erweiterbar. Diese Erweiterungen haben keinen Einfluss auf den Explosionsschutz und die allgemeine Sicherheit.



(16) **Besondere Bedingungen**

- Die Angabe der zulässigen Umgebungstemperaturen und Temperaturklassen entnehmen Sie bitte dem Benutzerhandbuch.
- Der Sensor mit der Anschlussleitungsbuchse (NTS 61) darf nur für Gasanwendungen verwendet werden.

(17) **Grundlegende Sicherheits- und Gesundheitsanforderungen**

Zusätzlich zu den grundlegenden Sicherheits- und Gesundheitsanforderungen, welche durch die unter Punkt 9 aufgeführten Normen erfüllt sind, sind noch folgende im Testbericht überprüften Bedingungen relevant:

| Paragraph | Thema |
|-----------|-------|
| Keine | |

(18) **Zeichnungen und Dokumente**

Siehe Testbericht „Hersteller Dokumente“

JUMO GmbH & Co. KG

Moritz-Juchheim-Straße 1
36039 Fulda, Germany

Tel.: +49 661 6003-0
Fax: +49 661 6003-500

E-Mail: mail@jumo.net
Internet: www.jumo.net



More than sensors + automation

UK Declaration of Conformity

Document No. UK 201
Manufacturer JUMO GmbH & Co. KG
Address Moritz-Juchheim-Straße 1, 36039 Fulda, Germany

Product
Name JUMO MIDAS S21 Ex
Type 404710
Data sheet no. 404710

Product description
Pressure transmitter for use in Ex areas.

We hereby declare in sole responsibility that the designated product fulfills the requirements of the statutory instruments.

1. Statutory instrument

Name Electromagnetic Compatibility Regulations 2016
No. 1091
Conformity assessment procedure Mod. A
Date of first application of the UKCA mark to the product 2023

Standards/Specifications applied

| Reference | Edition | Comment |
|--------------|---------|---------|
| EN 61326-1 | 2013 | |
| EN 61326-2-3 | 2013 | |

Valid for Type
404710/...

Document No.

UK 201

UK Declaration of Conformity

Seite: 1 von 3

JUMO GmbH & Co. KGMoritz-Juchheim-Straße 1
36039 Fulda, GermanyTel.: +49 661 6003-0
Fax: +49 661 6003-500E-Mail: mail@jumo.net
Internet: www.jumo.netMore than **sensors + automation****2. Statutory instrument**

Name The Restriction of the Use of Certain Hazardous Substances in Electrical and Electronic Equipment Regulations 2012 No. 3032

Conformity assessment procedure Mod. A

Date of first application of the UKCA mark to the product 2023

Standards/Specifications applied

| Reference | Edition | Comment |
|---|---------|---------|
| [VDK] Umweltrelevante Aspekte V1 bei der Produktentwicklung und -gestaltung | | |

Valid for Type

404710/...

3. Statutory instrument

Name The Equipment and Protective Systems Intended for Use in Potentially Explosive Atmospheres Regulations 2016 No. 1107

Conformity assessment procedure Mod. B+D

Date of first application of the UKCA mark to the product 2023

Standards/Specifications applied

| Reference | Edition | Comment |
|-------------|---------|---------|
| EN 60079-0 | 2018 | |
| EN 60079-11 | 2012 | |

Valid for Type

404710/...

Document No.

UK 201

UK Declaration of Conformity

Seite: 2 von 3

8 Zertifikate

JUMO GmbH & Co. KG

Moritz-Juchheim-Straße 1
36039 Fulda, Germany

Tel.: +49 661 6003-0
Fax: +49 661 6003-500

E-Mail: mail@jumo.net
Internet: www.jumo.net



More than **sensors + automation**

3.1 Type examination certificate

Certificate number

EPS 22 UKEX 1 088 X

Designated body

Bureau Veritas Consumer Products Services
United Kingdom Limited, 31 Kingsland Grange,
Woolston, Warrington, Cheshire, WA1 4RW

Quality assurance of the production process**Certificate number**

Available on request.

Designated body

Bureau Veritas Consumer Products Services
United Kingdom Limited, 31 Kingsland Grange,
Woolston, Warrington, Cheshire, WA1 4RW

Identification no.

8507

Issued by

JUMO GmbH & Co. KG

Place, date

Fulda, 2023-08-07

Legally binding signatures

Director of Global Sales
Markus Belmer

Head of Quality Department
Harald Gienger



- (1) **UK - Type Examination Certificate**
- (2) Equipment and protective systems intended for use in potentially explosive atmospheres – **UKSI 2016:1107 (as amended)**
- (3) UK - Type Examination Certificate Number
EPS 22 UKEX 1 088 X **Revision 0**
- (4) Equipment: Pressure transducer JUMO MIDAS S21 Ex 404710 / 000 - *** - 405 - *** - 20 - **
- (5) Manufacturer: JUMO GmbH & Co. KG
- (6) Address: Moritz-Juchheim-Straße 1
36039 Fulda
Germany
- (7) This equipment and any acceptable variation thereto are specified in the annex to this certificate and the documentation therein referred to.
- (8) Bureau Veritas Consumer Products Services United Kingdom Limited, approved body No. 8507 in accordance with UKSI 2016:1107 (as amended) Part 4, certifies that this equipment has been found to comply with the essential health and safety requirements relating to the design and construction of equipment and protective systems intended for use in potentially explosive atmospheres, given in Schedule 1 of UKSI 2016:1107 (as amended). The examination and test results are recorded in the confidential documentation under the reference number 22TH0288.
- (9) Compliance with the essential health and safety requirements has been assured by compliance with:
EN IEC 60079-0:2018 **EN 60079-11:2012**
- (10) If the sign "X" is placed after the certificate number, it indicates that the equipment is subject to special conditions for safe use specified in the annex to this certificate.
- (11) This UK - Type Examination Certificate relates only to the design and construction of the specified equipment in accordance with UKSI 2016:1107 (as amended). Further requirements apply to the manufacture of this equipment and its placing on the market. Those requirements are not covered by this certificate.
- (12) The marking of the equipment shall include the following:

II 2G Ex ib IIC T4...T6 Gb
II 2D Ex ib IIIC T70°C...T100°C Db



Certification department of explosion protection

Warrington, 31-07-2023

N. Wilkinson
Natalie Wilkinson



Certificates without signature and seal are void. This certificate is allowed to be distributed only if not modified. Extracts or modifications must be authorized by Bureau Veritas Consumer Products Services United Kingdom Limited, EPS 22 UKEX 1 088 X, Revision 0.

Bureau Veritas Consumer Products Services United Kingdom Limited
<https://www.bureauveritas.co.uk/consumer-products-testing>
+44 (0) 1925 854 360

Registered Office: 31 Kingsland Grange,
Woolston, Warrington, Cheshire, WA1 4RW

Registered in England & Wales
Company Number: 00852439

ZERT-0003-GBR-ZE-EX-V03 / TEMP-0005-GBR-ZE-EX-V01

1/4

8 Zertifikate



(13)

Annex

(14) **UK - Type Examination Certificate EPS 22 UKEX 1 088 X**

Revision 0

(15) Description of equipment:

The pressure transducer JUMO MIDAS S21 Ex type 404710 / 000 - *** - 405 - *** - 20 - ** serves for converting a physical measured quantity (pressure) into a standardized electrical signal (current signal 4 ... 20 mA). It is intended for use within potentially explosive areas.

The intrinsically safe circuit is connected with a non-detachable (cable length in plain text), circular connector M12x1 or a special electrical connection.

Measuring and supply circuit with the type of protection intrinsic safety

Ex ib IIC
Ex ib IIIC

Only for connection to a certified intrinsically safe circuit.

Rating:

Input and supply circuits:

With type of protection intrinsic safety Ex ib IIC

Only for connection to certified intrinsically safe circuit.

Maximum values for circular connector M12x1 and special electrical connection:

$U_i \leq 28 \text{ V}$
 $I_i \leq 100 \text{ mA}$
 $P_i \leq 750 \text{ mW}$
 $C_i \leq 10.4 \text{ nF}$ (effective internal capacitance)
 $L_i \approx 0 \text{ uH/m}$ (effective internal inductance)

Maximum values for electrical connection with non-detachable cable:

$U_i \leq 28 \text{ V}$
 $I_i \leq 100 \text{ mA}$
 $P_i \leq 750 \text{ mW}$
 $C_i \leq 10.4 \text{ nF} + 100 \text{ pF/m} \cdot \text{cable length}$
 $L_i \leq 1 \text{ uH/m} \cdot \text{cable length}$

Type designation:

Example of type designation 404710/000 - 459 - 405 - 504 - 20 - 11 / 000

(1) (2) (3) (4) (5) (6) (7)

(1) Basic type

404710/000 JUMO MIDAS S21 Ex – Pressure transducer for use in potentially explosive atmospheres

Certificates without signature and seal are void. This certificate is allowed to be distributed only if not modified. Extracts or modifications must be authorized by Bureau Veritas Consumer Products Services United Kingdom Limited. EPS 22 UKEX 1 088 X, Revision 0.

Bureau Veritas Consumer Products Services United Kingdom Limited
<https://www.bureauveritas.co.uk/consumer-products-testing>
+44 (0) 1925 854 360

Registered Office: 31 Kingsland Grange,
Woolston, Warrington, Cheshire, WA1 4RW

Registered in England & Wales
Company Number: 00852439

ZERT-0003-GBR-ZE-EX-V03 / TEMP-0005-GBR-ZE-EX-V01

2/4



UK - Type Examination Certificate EPS 22 UKEX 1 088 X

Revision 0

(2)* Pressure rated measuring range

- 432 0 to 30 bar relative pressure
- 451 0 to 0.25 bar relative pressure
- 452 0 to 0.4 bar relative pressure
- 453 0 to 0.6 bar relative pressure
- 454 0 to 1 bar relative pressure
- 455 0 to 1.6 bar relative pressure
- 456 0 to 2.5 bar relative pressure
- 457 0 to 4 bar relative pressure
- 458 0 to 6 bar relative pressure
- 459 0 to 10 bar relative pressure
- 460 0 to 16 bar relative pressure
- 461 0 to 25 bar relative pressure
- 462 0 to 40 bar relative pressure
- 463 0 to 60 bar relative pressure
- 464 0 to 100 bar relative pressure
- 475 -0.25 to 0 bar relative pressure
- 476 -0.4 to 0 bar relative pressure
- 477 -0.6 to 0 bar relative pressure
- 478 -1 to 0 bar relative pressure
- 479 -1 to +0.6 bar relative pressure
- 480 -1 to +1.5 bar relative pressure
- 481 -1 to +3 bar relative pressure
- 482 -1 to +5 bar relative pressure
- 483 -1 to +9 bar relative pressure
- 484 -1 to +15 bar relative pressure
- 485 -1 to +24 bar relative pressure
- 487 0 to 0.6 bar absolute pressure
- 488 0 to 1 bar absolute pressure
- 489 0 to 1.6 bar absolute pressure
- 490 0 to 2.5 bar absolute pressure
- 491 0 to 4 bar absolute pressure
- 492 0 to 6 bar absolute pressure
- 493 0 to 10 bar absolute pressure
- 494 0 to 16 bar absolute pressure
- 495 0 to 25 bar absolute pressure
- 998 special measuring range for absolute pressure
- 999 special measuring range for relative pressure

(3) Electrical output

- 405 4 to 20 mA, two-wire

(4)* Process connection

- 502 G 1/4 according to DIN EN 837
- 504 G 1/2 according to DIN EN 837
- 511 1/4-18 NPT according to DIN EN 837
- 512 1/2-14 NPT according to DIN EN 837
- 521 G 3/4 according to DIN 3852-11
- 523 G 1/2 according to DIN 3852-11
- 563 7/16-20 UNF inside with vent core pusher
- 583 M20 x 1.5 with stud
- 999 according to customer specification

(5) Material of process connection

- 20 CrNi (stainless steel)

Certificates without signature and seal are void. This certificate is allowed to be distributed only if not modified. Extracts or modifications must be authorized by Bureau Veritas Consumer Products Services United Kingdom Limited, EPS 22 UKEX 1 088 X, Revision 0.

Bureau Veritas Consumer Products Services United Kingdom Limited
<https://www.bureauveritas.co.uk/consumer-products-testing>
 +44 (0) 1925 854 360

Registered Office: 31 Kingsland Grange,
 Woolston, Warrington, Cheshire, WA1 4RW

Registered in England & Wales
 Company Number: 00852439

ZERT-0003-GBR-ZE-EX-V03 / TEMP-0005-GBR-ZE-EX-V01

3/4

8 Zertifikate



UK - Type Examination Certificate EPS 22 UKEX 1 088 X

Revision 0

(6) Electrical connection

- 11 attached cable
- 24 lose stranded wires
- 36 round plug M12×1
- 61 cable socket DIN EN 175301-803 form A
- 99 special electrical connection

(7)* Additional options

- 000 without
- 462 inverted output signal
- 591 choking coil in pressure channel
- 624 free from oil and grease
- 630 widened pressure channel

*) The numerical type keys can be extended with values not named here in the sense of the basic test. These extensions have no effect on the explosion protection and general safety.

(16) Reference number: 22TH0288

(17) Special conditions for safe use:

For details concerning the admissible ambient temperatures and temperature classes please refer to the user's manual.

The sensor with the connector cable socket (NTS 61) may only be used for gas applications.

(18) Essential health and safety requirements:

Met by compliance with standards.

Certification department of explosion protection

Warrington, 31-07-2023



Natalie Wilkinson

Certificates without signature and seal are void. This certificate is allowed to be distributed only if not modified. Extracts or modifications must be authorized by Bureau Veritas Consumer Products Services United Kingdom Limited, EPS 22 UKEX 1 088 X, Revision 0.

Bureau Veritas Consumer Products Services United Kingdom Limited
<https://www.bureauveritas.co.uk/consumer-products-testing>
+44 (0) 1925 854 360

Registered Office: 31 Kingsland Grange,
Woolston, Warrington, Cheshire, WA1 4RW

Registered in England & Wales
Company Number: 00852439

ZERT-0003-GBR-ZE-EX-V03 / TEMP-0005-GBR-ZE-EX-V01

4/4

| | | | | | | | |
|---|--|-----------|-----------|-----------|-----------------|---------------|-----------------|
|  | <p style="text-align: center;">产品中有害物质的名称及含量 China EEP Hazardous Substances Information</p> | | | | | | |
| | 产品组别 Product group: 404710 部件名称 Component Name | 铅 (Pb) | 汞 (Hg) | 镉 (Cd) | 六价铬 (Cr(VI)) | 多溴联苯 (PBB) | 多溴二苯醚 (PBDE) |
| 外壳 Housing (Gehäuse) | ○ | ○ | ○ | ○ | ○ | ○ | |
| 过程连接 Process connection (Prozessanschluss) | X | ○ | ○ | ○ | ○ | ○ | |
| 螺母 Nuts (Mutter) | ○ | ○ | ○ | ○ | ○ | ○ | |
| 螺钉 Screw (Schraube) | ○ | ○ | ○ | ○ | ○ | ○ | |
| <p>本表格依据SJ/T 11364的规定编制。 This table is prepared in accordance with the provisions SJ/T 11364. ○：表示该有害物质在该部件所有均质材料中的含量均在GB/T 26572规定的限量要求以下。 Indicate the hazardous substances in all homogeneous materials' for the part is below the limit of the GB/T 26572. x：表示该有害物质至少在该部件的某一均质材料中的含量超出GB/T 26572规定的限量要求。 Indicate the hazardous substances in at least one homogeneous materials' of the part is exceeded the limit of the GB/T 26572.</p> | | | | | | | |



JUMO GmbH & Co. KG

Moritz-Juchheim-Straße 1
36039 Fulda, Germany

Telefon: +49 661 6003-715
Telefax: +49 661 6003-606
E-Mail: mail@jumo.net
Internet: www.jumo.net

Lieferadresse:
Mackenrodtstraße 14
36039 Fulda, Germany

Postadresse:
36035 Fulda, Germany

Technischer Support Deutschland:

Telefon: +49 661 6003-9135
Telefax: +49 661 6003-881899
E-Mail: support@jumo.net

JUMO Mess- und Regelgeräte GmbH

Pfarrgasse 48
1230 Wien, Austria

Telefon: +43 1 610610
Telefax: +43 1 6106140
E-Mail: info.at@jumo.net
Internet: www.jumo.at

Technischer Support Österreich:

Telefon: +43 1 610610
Telefax: +43 1 6106140
E-Mail: info.at@jumo.net

JUMO Mess- und Regeltechnik AG

Laubisrütistrasse 70
8712 Stäfa, Switzerland

Telefon: +41 44 928 24 44
Telefax: +41 44 928 24 48
E-Mail: info@jumo.ch
Internet: www.jumo.ch

Technischer Support Schweiz:

Telefon: +41 44 928 24 44
Telefax: +41 44 928 24 48
E-Mail: info@jumo.ch



JUMO MIDAS S21 Ex

Pressure Transmitter for Use in Ex-areas



Operating Manual

40471000T90Z000K000

EN/2024-05-15



Further information and downloads



qr-404710-en.jumo.info

Table of contents

| | | |
|----------|---|-----------|
| 1 | Safety information | 4 |
| 1.1 | Warning symbols | 4 |
| 1.2 | Note symbols | 4 |
| 1.3 | Hybrid mixtures | 4 |
| 2 | Introduction | 5 |
| 3 | Identifying the device version | 7 |
| 3.1 | Nameplate | 7 |
| 3.2 | Order details | 7 |
| 3.3 | Scope of delivery | 9 |
| 3.4 | Accessories | 9 |
| 4 | Technical data | 10 |
| 4.1 | General Information | 10 |
| 4.2 | Input | 10 |
| 4.2.1 | Measuring range and accuracy | 10 |
| 4.3 | Output | 11 |
| 4.4 | Mechanical features | 11 |
| 4.5 | Environmental influences | 12 |
| 4.6 | Electrical data | 12 |
| 4.7 | Approvals and approval marks | 13 |
| 5 | Mounting | 14 |
| 5.1 | General information | 14 |
| 5.2 | Pressure connection | 15 |
| 5.3 | Dimensions | 16 |
| 5.3.1 | Electrical connection | 16 |
| 5.3.2 | Process connections | 18 |
| 6 | Installation | 20 |
| 6.1 | Electrical connection | 20 |
| 6.2 | Connection diagram | 21 |
| 6.3 | Connection example | 21 |
| 7 | Maintenance, cleaning, returns, disposal | 22 |
| 7.1 | Maintenance | 22 |
| 7.2 | Cleaning | 22 |
| 7.3 | Returns | 22 |
| 7.4 | Disposal | 22 |
| 8 | Certificates | 23 |

1 Safety information

1.1 Warning symbols



DANGER!

This symbol indicates that **personal injury from electrocution** may occur if the appropriate precautionary measures are not taken.



WARNING!

This symbol in connection with the signal word indicates that **personal injury** may occur if the respective precautionary measures are not carried out.



CAUTION!

This symbol in connection with the signal word indicates that **material damage or data loss** will occur if the respective precautionary measures are not taken.



CAUTION!

This symbol indicates that **components could be destroyed** by electrostatic discharge (ESD = Electro Static Discharge) if the respective cautionary measures are not taken.

Only use the ESD packages intended for this purpose to return device inserts, assembly groups, or assembly components.



READ THE DOCUMENTATION!

This symbol, which is attached to the device, indicates that the associated **documentation for the device** must be **observed**. This is necessary to identify the nature of the potential hazard, and to take measures to prevent it.

1.2 Note symbols



NOTE!

This symbol refers to **important information** about the product, its handling, or additional benefits.



REFERENCE!

This symbol refers to **additional information** in other sections, chapters, or other manuals.

1.3 Hybrid mixtures

Hybrid mixtures are explosive mixtures of flammable gases, vapors, or mists with flammable dusts. In particular, equipment used in potentially explosive areas where hybrid mixtures are present must be checked. The operator is responsible for checking that the equipment is suitable for such uses.



DANGER!

The declaration of conformity, the examination certificate (both found at the end of this operating manual), and the relevant regulations for sensors and supply units in potentially explosive areas must be observed!

The sensors must only be operated on intrinsically safe electrical circuits appropriate for the version.

- ▶ The admissible values can be found in the certificate.
-

General information

The pressure transmitter measures the pressure of gases, vapors, and liquids. The device operates according to the piezoresistive measuring principle. The output signal is a load-independent direct current which is linearly proportional to the input pressure.

The pressure transmitter type 404710 meets the requirements:

- of device group II in the potentially explosive area of zones 1 and 2
- of device group III in the potentially explosive area of zones 21 und 22

The EC-type examination certificate of the pressure transmitter reads:

SEV 09 ATEX 0101 X



CAUTION!

Do not damage the membrane of the pressure transmitter!

The followings measures must be observed:

- Do not insert any articles into the pressure connection hole!
- Do not direct the pressure blast at the membrane!
- Do not deform the membrane. Under certain circumstances, even touching the membrane with your fingers may cause damage.
- The pressure to be measured must not exceed the admissible overpressure of the pressure transmitter even at pressure peaks. Very high pressure peaks (water hammer) may damage the pressure transmitter. Under these conditions, take the appropriate measures (e.g. insert a damping element).

2 Introduction

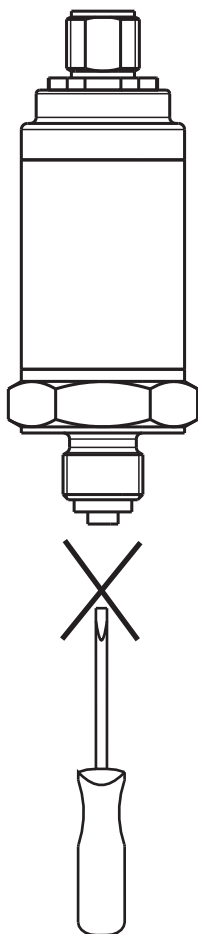

CAUTION!

In order to prevent damage to the pressure transmitter and to safeguard the process, mounting, installation, and startup must only be performed by qualified personnel. Personnel must be familiar with country-specific regulations and be aware of applied standards and directives to prevent bodily injuries and material damage.

- ▶ Qualified personnel must have read the operating manual, noted the nameplate, and understood both so that the instructions can be followed. Modifications and repairs must only be carried out if the operating manual permits it.
Keep the operating manual at a location that is readily accessible to all users.
-

3 Identifying the device version

3.1 Nameplate

Example:

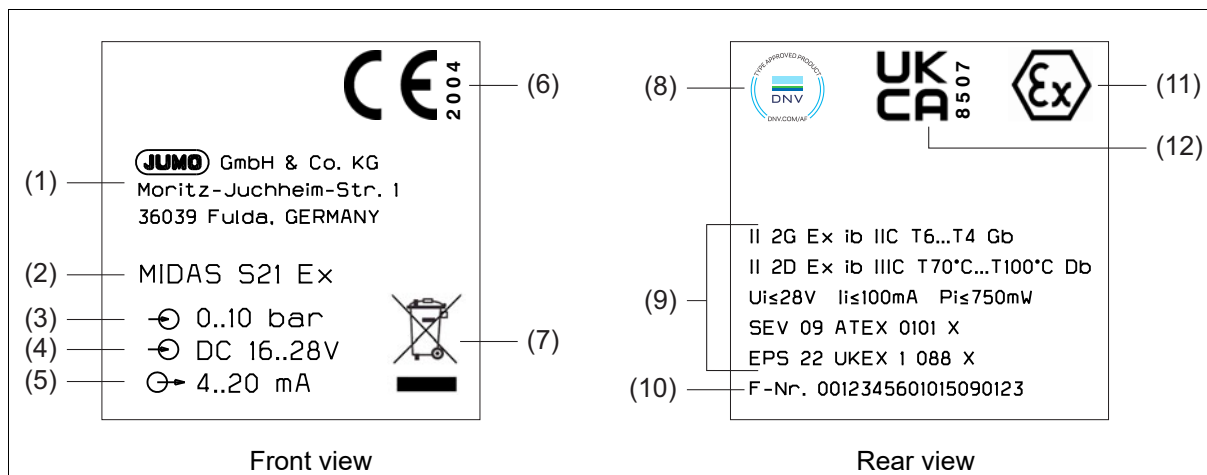

| | | | |
|---|---------------------------|----|-----------------------------|
| 1 | Manufacturer and address | 7 | Disposal |
| 2 | Device designation | 8 | DNV identification marking |
| 3 | Measuring range | 9 | Ex specifications |
| 4 | Voltage supply | 10 | Fabrication number |
| 5 | Output | 11 | Ex identification marking |
| 6 | CE identification marking | 12 | UKCA identification marking |

3.2 Order details

| | |
|--|--|
| (1) Basic type | |
| 404710/000 | JUMO MIDAS S21 Ex – Pressure transmitter for use in Ex-areas |
| (2) Input – nominal measuring range | |
| 451 | 0 to 0.25 bar relative pressure |
| 452 | 0 to 0.4 bar relative pressure |
| 453 | 0 to 0.6 bar relative pressure |
| 454 | 0 to 1 bar relative pressure |
| 455 | 0 to 1.6 bar relative pressure |
| 456 | 0 to 2.5 bar relative pressure |
| 457 | 0 to 4 bar relative pressure |
| 458 | 0 to 6 bar relative pressure |
| 459 | 0 to 10 bar relative pressure |
| 460 | 0 to 16 bar relative pressure |
| 461 | 0 to 25 bar relative pressure |
| 432 | 0 to 30 bar relative pressure |
| 462 | 0 to 40 bar relative pressure |
| 463 | 0 to 60 bar relative pressure |
| 464 | 0 to 100 bar relative pressure |
| 475 | -0.25 to 0 bar relative pressure |
| 476 | -0.4 to 0 bar relative pressure |
| 477 | -0.6 to 0 bar relative pressure |
| 478 | -1 to 0 bar relative pressure |

3 Identifying the device version

| | |
|--|---|
| 479 | -1 to +0.6 bar relative pressure |
| 480 | -1 to +1.5 bar relative pressure |
| 481 | -1 to +3 bar relative pressure |
| 482 | -1 to +5 bar relative pressure |
| 483 | -1 to +9 bar relative pressure |
| 484 | -1 to +15 bar relative pressure |
| 485 | -1 to +24 bar relative pressure |
| 487 | 0 to 0.6 bar absolute pressure |
| 488 | 0 to 1 bar absolute pressure |
| 489 | 0 to 1.6 bar absolute pressure |
| 490 | 0 to 2.5 bar absolute pressure |
| 491 | 0 to 4 bar absolute pressure |
| 492 | 0 to 6 bar absolute pressure |
| 493 | 0 to 10 bar absolute pressure |
| 494 | 0 to 16 bar absolute pressure |
| 495 | 0 to 25 bar absolute pressure |
| 998 | Special measuring range for absolute pressure |
| 999 | Special measuring range for relative pressure |
| (3) Output | |
| 405 | 4 to 20 mA, 2-wire |
| (4) Process connection | |
| 502 | G 1/4 DIN EN 837 |
| 503 | G 3/8 DIN EN 837 |
| 504 | G 1/2 DIN EN 837 (standard) |
| 511 | 1/4-18 NPT DIN EN 837 |
| 512 | 1/2-14 NPT DIN EN 837 |
| 521 | G 1/4 DIN 3852-11 |
| 523 | G 1/2 DIN 3852 T11 |
| 563 | 7/16-20 UNF interior with valve core handle |
| 583 | M20 × 1.5 with pin |
| 999 | According to customer specifications |
| (5) Process connection material | |
| 20 | CrNi (stainless steel) |
| (6) Electrical connection | |
| 11 | Connecting cable |
| 24 | Loose stranded wires |
| 36 | M12 plug connector |
| 61 | Line socket DIN EN 175301-803 Form A ^a |
| 99 | Special electrical connection |
| (7) Extra code | |
| 085 | UKEX approval |
| 240 | EAC Ex approval |
| 462 | Inverted output signal |
| 591 | Restrictor in pressure channel |
| 624 | Free from oil and grease |
| 630 | Enlarged pressure duct |

3 Identifying the device version

| | |
|-----|---------------------------|
| 880 | DNV approval ^b |
|-----|---------------------------|

^a Only certified for gas application.

^b Only in conjunction with M12 plug connector or line socket available.



| | | | | | | | | | | | | | |
|----------------------|------------|-----|-----|-----|-----|-----|-----|---|----|---|----|---|-----|
| | (1) | (2) | (3) | (4) | (5) | (6) | (7) | | | | | | |
| Order code | | | | | | | | | | | | | |
| Order example | 404710/000 | - | 459 | - | 405 | - | 504 | - | 20 | - | 11 | / | 000 |

3.3 Scope of delivery

| |
|-------------------------------|
| Device in the ordered version |
| Operating manual |

3.4 Accessories

The accessories are not checked according to DNV requirements.

| Description | Description | Part no. |
|--|---|----------|
| <p>Ex-i repeater power supply / input isolating amplifier</p>  | <p>The Ex-i repeater power supply / input isolating amplifier is designed for operating intrinsically safe transmitters (Ex-i) and mA current sources installed in potentially explosive (Ex) areas.</p> <p>Two-wire transmitters are supplied with energy and analog 0/4 to 20 mA measured values are transmitted from the Ex-area to the non-Ex-area. The output of the module can be operated actively or passively. Further technical data and the relevant safety requirements are available in the operating manual B 707530.0.</p> | 00577948 |
| <p>Cable box, straight</p>  | <p>The PVC connecting cable is 2 m long and has a 4-pin, straight M12 × 1 connector with gold-plated contacts on the device side.</p> | 00404585 |
| <p>Cable box, angled</p>  | <p>The PVC connecting cable is 2 m long and has a 4-pin, angled M12 × 1 connector with gold-plated contacts on the device side.</p> | 00409334 |

4 Technical data

4.1 General Information

| | |
|--------------------------|--|
| Reference conditions | According to DIN EN 60770-1 and DIN IEC 61298-1 |
| Sensor | |
| Material | Silicon sensor with stainless steel membrane |
| Pressure transfer medium | Synthetic oil |
| Admissible load changes | > 10 million |
| Mounting position | Any |
| Calibration position | Device upright, process connection at the bottom |

4.2 Input

4.2.1 Measuring range and accuracy

| Measuring range bar | Linearity ^a % MSP ^f | Accuracy at | | Long-term stability ^b % MSP per year | Overload capacity ^c bar | Burst pressure bar |
|---|--|-----------------------------|--|--|--|--------------------------|
| | | 20 °C ^d % MSP | -20 °C to +85 °C ^e % MSP | | | |
| 0 to 0.6 bar relative/absolute pressure | 0.3 | 0.5 | 1.2 | < 0,2 | 2.4 | 6 |
| 0 to 1 bar relative/absolute pressure | 0.3 | 0.5 | 1.2 | | 4 | 10 |
| 0 to 1.6 bar relative/absolute pressure | 0.3 | 0.4 | 1.0 | | 6.4 | 16 |
| 0 to 2.5 bar relative/absolute pressure | 0.3 | 0.4 | 1.0 | | 10 | 25 |
| 0 to 4 bar relative/absolute pressure | 0.3 | 0.4 | 1.0 | | 16 | 40 |
| 0 to 6 bar relative/absolute pressure | 0.3 | 0.4 | 1.0 | | 24 | 60 |
| 0 to 10 bar relative/absolute pressure | 0.3 | 0.4 | 1.0 | | 40 | 100 |
| 0 to 16 bar relative/absolute pressure | 0.3 | 0.4 | 1.0 | | 64 | 160 |
| 0 to 25 bar relative/absolute pressure | 0.3 | 0.4 | 1.0 | | 100 | 250 |
| 0 to 30 bar relative/absolute pressure | 0.3 | 0.4 | 1.0 | | 100 | 250 |
| 0 to 0.25 bar relative pressure | 0.3 | 0.5 | 1.2 | | 1 | 2.5 |
| 0 to 0.4 bar relative pressure | 0.3 | 0.5 | 1.2 | | 1.6 | 4 |
| 0 to 40 bar relative pressure | 0.3 | 0.4 | 1.0 | | 300 | 400 |
| 0 to 60 bar relative pressure | 0.3 | 0.4 | 1.0 | | 300 | 400 |
| 0 to 100 bar relative pressure | 0.3 | 0.4 | 1.0 | | 300 | 400 |
| -0.25 to 0 bar relative pressure | 0.3 | 0.5 | 1.2 | | 1 | 2.5 |
| -0.4 to 0 bar relative pressure | 0.3 | 0.5 | 1.2 | | 1.6 | 4 |
| -0.6 to 0 bar relative pressure | 0.3 | 0.5 | 1.2 | | 2.4 | 6 |
| -1 to 0 bar relative pressure | 0.3 | 0.5 | 1.2 | | 4 | 10 |
| -1 to +0.6 bar relative pressure | 0.3 | 0.4 | 1.0 | | 6.4 | 16 |
| -1 to +1.5 bar relative pressure | 0.3 | 0.4 | 1.0 | 10 | 25 | |
| -1 to +3 bar relative pressure | 0.3 | 0.4 | 1.0 | 16 | 40 | |
| -1 to +5 bar relative pressure | 0.3 | 0.4 | 1.0 | 24 | 60 | |
| -1 to +9 bar relative pressure | 0.3 | 0.4 | 1.0 | 40 | 100 | |
| -1 to +15 bar relative pressure | 0.3 | 0.4 | 1.0 | 64 | 160 | |
| -1 to +24 bar relative pressure | 0.3 | 0.4 | 1.0 | 100 | 250 | |

^a Linearity according to limit point setting

^b Reference conditions EN 61298-1

^c All pressure transmitters are vacuum proof.

4 Technical data

- ^d Includes: linearity, hysteresis, repeatability, deviation of measuring range initial value (offset), and measuring range end value
- ^e Includes: linearity, hysteresis, repeatability, deviation of measuring range initial value (offset) and measuring range end value, thermal effect on measuring range start (offset), and measuring span
- ^f MSP = Measuring span

4.3 Output

| | |
|--|---|
| Output signal Current | 4 to 20 mA, two-wire |
| Step response T_{90} | ≤ 2 ms |
| Burden 4 to 20 mA, two-wire Burden influence | $R_B \leq (U_B - 16 \text{ V}) \div 0.022 \text{ A} (\Omega)$ $\leq 0.004 \%$ per 100 Ω |

4.4 Mechanical features

| | |
|-------------------------------------|-------------------------------------|
| Material | |
| Process connection | 316 Ti |
| According to customer specification | 316 L |
| Membrane | 316 L |
| Housing | 304 |
| Connecting cable | Silicone |
| Loose stranded wires | Silicone |
| Round plug M12 × 1 | PA, nickel-plated zinc diecast |
| Line socket | |
| Without DNV approval | PA 66 GF, PA6-GF30, EPDM |
| With DNV approval | PBT-GF30, PA, EPDM |
| Electrical connection | |
| Special version | PUR |
| Weight | 170 g with process connection G 1/2 |

4 Technical data

4.5 Environmental influences

| | |
|------------------------------------|---|
| Ambient temperature | Equipment Protection Level Gb temperature class T4: -40 to +85 °C T5: -40 to +70 °C T6: -40 to +55 °C Equipment Protection Level Db maximum surface temperature T100 °C: -40 to +85 °C T85 °C: -40 to +70 °C T70 °C: -40 to +55 °C |
| Medium temperature | -40 to +85 °C |
| Storage temperature | -40 to +100 °C |
| Protection type ^a | IP65, according to DIN EN 60529 |
| Electromagnetic compatibility (EC) | According to EN 61326-2-3:2022 |
| Interference emission | Class B ^b |
| Interference immunity | Industrial requirement |
| Mechanical load | |
| Shock resistance | 100 g/1 ms, according to DIN EN 60068-2-27 |
| Vibration resistance | 20 g at 15 to 2000 Hz, according to DIN EN 60068-2-6 |

^a The protection type is only achieved with a suitable mounted counter piece. The connecting cable diameter for cable socket is minimum 4,5 mm, maximum 7 mm.

^b The product is suitable for industrial use as well as for households and small businesses.

For the special conditions for use, observe the examination certificate.



4.6 Electrical data

| | |
|-----------------------------------|--|
| Voltage supply U_B ^a | |
| Nominal voltage | DC 24 V |
| 4 to 20 mA | |
| Without DNV approval | DC 16 to 28 V |
| With DNV approval | DC 21 to 24 V |
| Current consumption | ≤ 23 mA |
| Electrical circuit | Intrinsically safe |
| Electrical connection | |
| Connection elements | Attached cable, loose stranded wires, round plug M12 ^b , line socket ^b |

^a Residual ripple: the voltage peaks must not exceed or fall below the specified voltage supply values!

^b With DNV approval.

4.7 Approvals and approval marks

| | | |
|---|---|---|
|  | Designation Testing agency Certificate no. Inspection basis Valid for | ATEX Eurofins Electrosuisse Product Testing AG SEV 09 ATEX 0101 X EN 60079-0, EN 60079-11 Type 404710 |
| | Designation Testing agency Certificate no. Inspection basis Valid for | UKEX Bureau Veritas EPS 22 UKEX 1 088 X EN IEC 60079-0, EN 60079-11 Type 404710/.../085 |
|  | Designation Testing agency Certificate no. Inspection basis Valid for | DNV DNV TAA0000211 DNV-CG-0339 Type 404710/...-36/062, Type 404710/...-61/062 |
|  | Designation Testing agency Certificate no. Inspection basis Valid for | EAC Ex ПрофиТест / ProfiTest RU C-DE.HB07.B.00659/22 TP TC 012/2011 Type 404710 |

5 Mounting



DANGER!

The pressure transmitter does not meet the "Equipment with safety function" requirements according to the Pressure Equipment Directive 2014/68/EU.

- ▶ The current relevant regulations must be observed for dangerous media, e.g. oxygen, acetylene, flammable, and poisonous substances, as well as for cooling systems and pressure tanks etc. The national and international safety and accident prevention regulations must be observed! Failure to observe these guidelines may result in bodily injuries and material damage! The plant operator is responsible for compliance with the legal regulations! Only suitably qualified persons are permitted to work at this device.
-

5.1 General information

Prior to mounting



DANGER!

Depressurize the plant prior to mounting the pressure transmitter!



CAUTION!

The pressure transmitter may only be used for media to which the membrane is sufficiently chemically resistant (corrosion).
Ensure there is an electrically conductive connection between the pressure transmitter and the process connection (plant).



NOTE!

Select a freely accessible and low-vibration installation location, preferably near the measuring point. Ensure the admissible ambient temperature is adhered to (take into account possible heat radiation). The pressure transmitter may be mounted above or below the pressure sensing point. The rated position of the pressure transmitter is upright. The pressure transmitter may also be mounted in another position depending on the measuring point conditions.



NOTE!

For the special conditions for use, the examination certificate must be observed,
⇒ chapter 8 "Certificates", Page 23.

5.2 Pressure connection

Seals



DANGER!

A flat seal, e.g. according to DIN EN 837, must be used for the appropriate process connection for the ignition protection type intrinsic safety!

- ▶ The pressure connection must be checked for seal tightness once established!
If the pressure transmitter is screwed into a threaded hole, the **full length** of the thread of the pressure transmitter must be used!
-



NOTE!

The correct tightening torque is dependent on the size, material, and form of the seal used, as well as the pressure connection of the pressure transmitter.

5 Mounting

5.3 Dimensions

5.3.1 Electrical connection

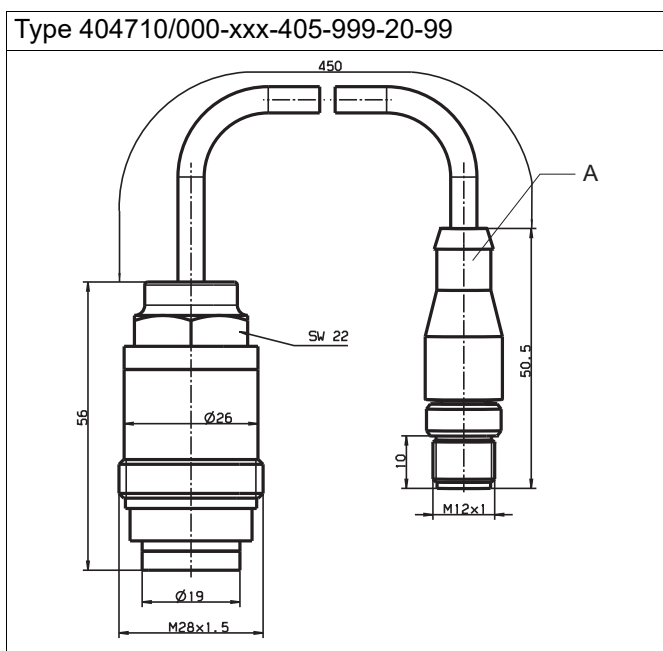
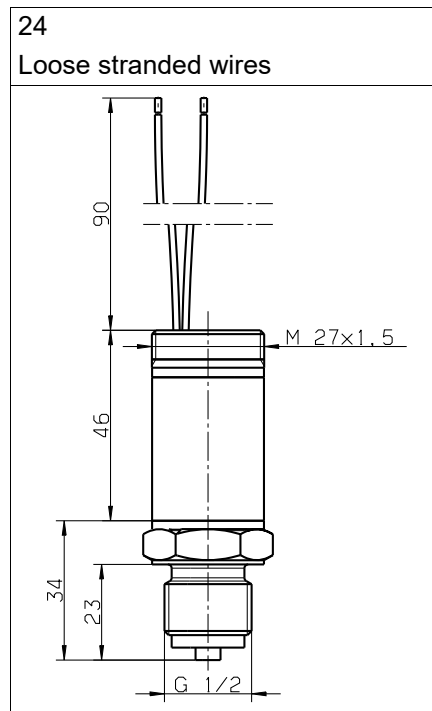
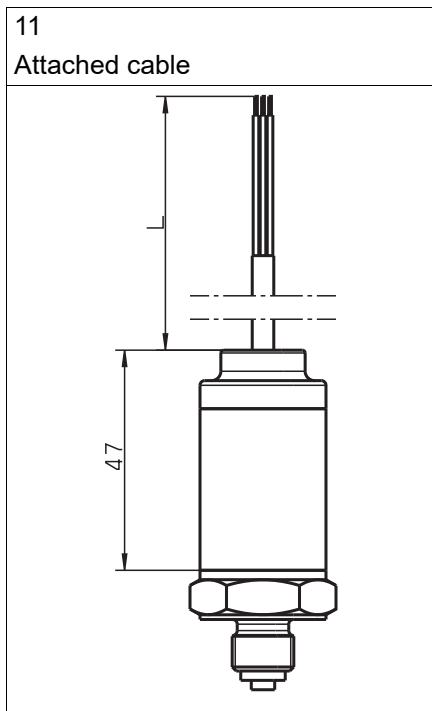

A Cable connector 4 × 0.34, 4-pin

With DNV approval

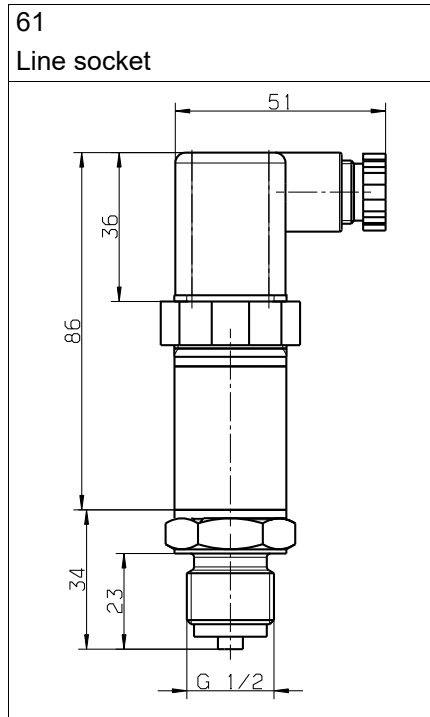
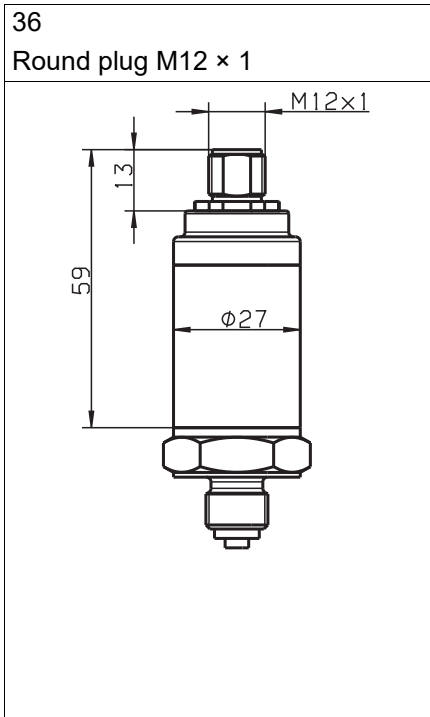

5 Mounting

5.3.2 Process connections

Not front-flush

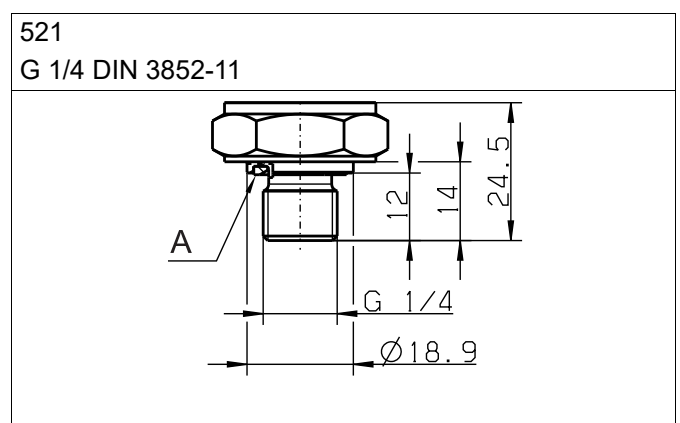
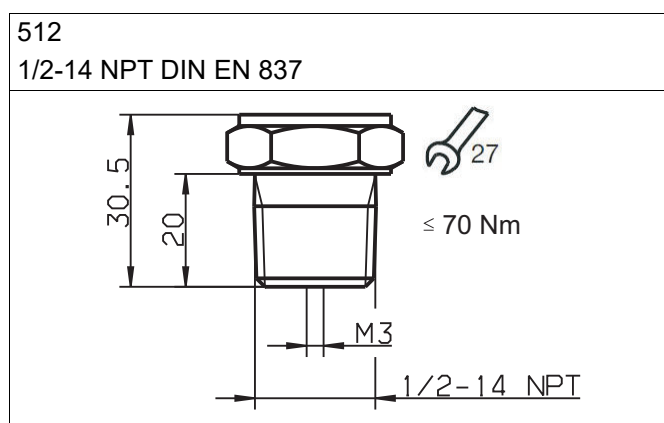
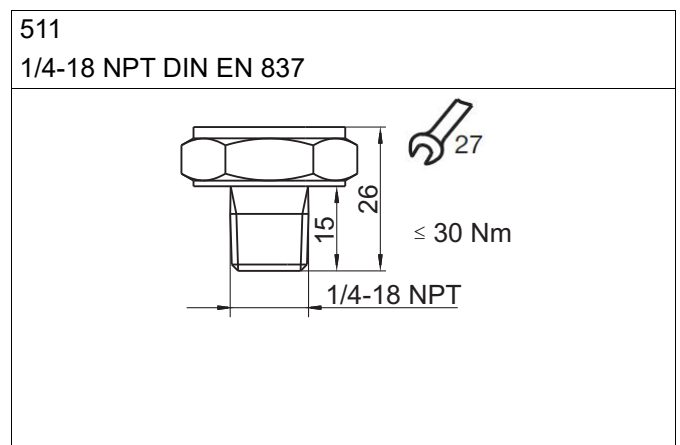
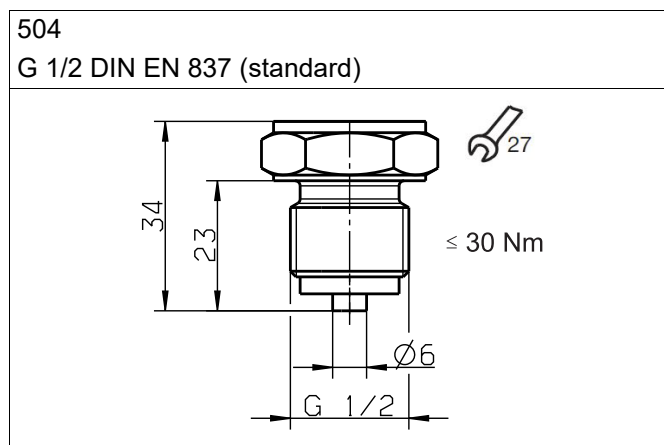
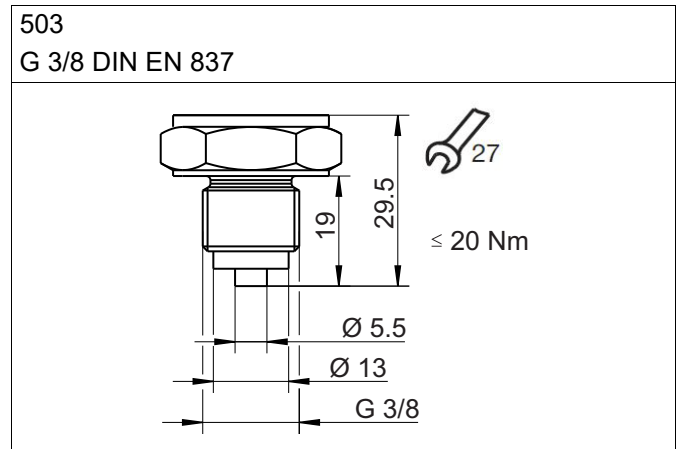
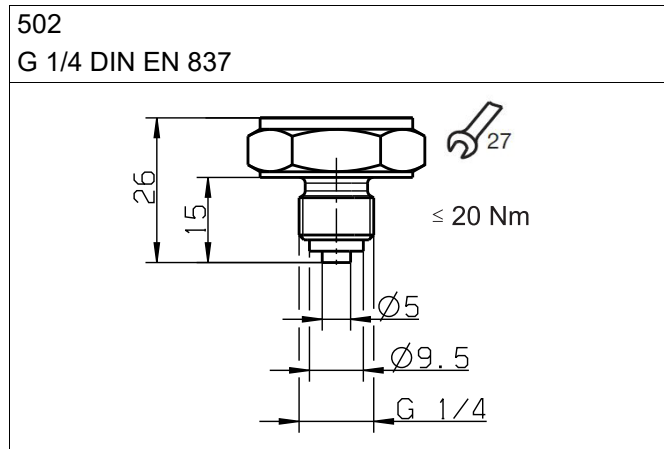

A Profile seal G 1/4

5 Mounting

523
G 1/2 DIN 3852-11

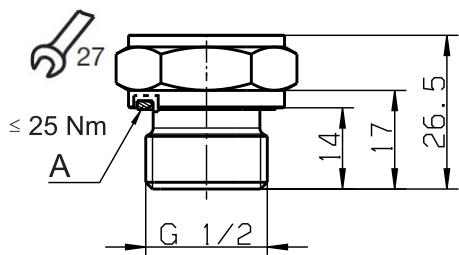

A Profile seal G 1/2

563
7/16-20 UNF interior with valve core handle

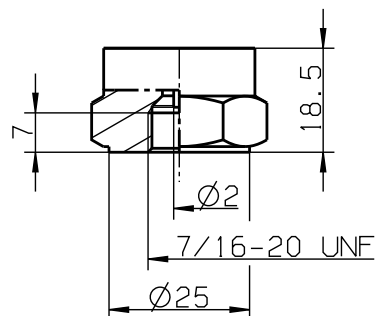

583
M20 × 1.5 with pin

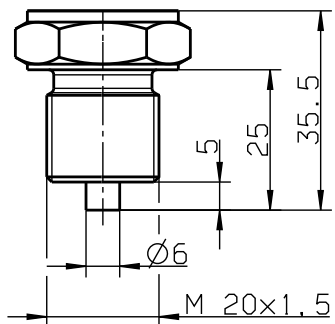

6 Installation

6.1 Electrical connection



DANGER!

The relevant regulations must be observed during electrical connection:

- Regulation for electrical plants in potentially explosive rooms (Elex V)
- Regulation for the installation of electrical plants in potentially explosive areas
- EC-type examination certificate

► The electrical connection must only be carried out by qualified personnel!

The voltage supply must be intrinsically safe and must not exceed the following maximum values:

U_i : DC 28 V

I_i : 100 mA

P_i : 750 mW

Effective inner inductivity L: negligibly small

Effective inner capacity C: ≤ 10.4 nF

In intrinsically safe electrical circuits, only intrinsically safe, certified measuring devices may be used!

For electrical connection 11 (attached cable) the following values results in dependence of the cable length L:

$$U_i \leq 28 \text{ V}$$

$$I_i \leq 100 \text{ mA}$$

$$P_i \leq 750 \text{ mW}$$

$$C_i \leq 10.4 \text{ nF} + 100 \frac{\text{pF}}{\text{m}} \times L$$

$$L_i \leq 1 \frac{\mu\text{H}}{\text{m}} \times L$$

General information

- Maximum cable length 50 m
- Minimum bending radius 120 mm (for permanent laying)
- Protect the cable end against humidity
- Observe the length-dependent inductivities and capacities if lengthening the cable
- Lay the signal lines isolated from cables with a voltage of > 60 V
- Use protected cables with twisted cores
- Keep away from large, electrical plants



NOTE!



The intrinsically safe electrical circuit must be restricted to overvoltage category I as stipulated in IEC 60664-1. The electrical circuit supply is only to be provided by a certified, intrinsically safe power source with a protection level of "ib".



NOTE!

For the special conditions for use, the examination certificate must be observed,
⇒ chapter 8 "Certificates", Page 23.

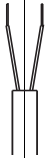
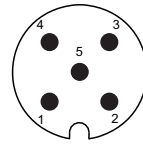
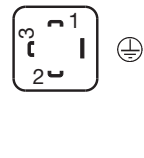
6.2 Connection diagram

| Connection | | Terminal assignment (Figure: connection to the pressure transmitter) | | | |
|--|---|---|---|---|---|
| | |  |  |  |  |
| | | 11 Attached cable | 24 Loose stranded wires | 36 Round plug M12 x 1 | 61 Cable socket |
| 4 to 20 mA, two-wire (output 405) | | | | | |
| Voltage supply DC 16 to 28 V | U _B /S+ 0 V/S- | BU BK | BU BK | 1 BN 3 BU | 1 2 |
| Functional bonding conductor FB ^a |  | - | - | - | - |

^a The pressure transmitter has to be connected to the potential equalization system of the plant via the process connection.

| Color coding: connecting cable round plug M12 x 1 | 1 BN | Brown |
|--|------|-------|
| | | 2 WH |
| | 3 BU | Blue |
| | 4 BK | Black |

The color coding is **only** valid for A-coded standard cables!



CAUTION!

Ground (functional ground) the case of the pressure transmitter using the process connection to protect against electromagnetic fields and electromagnetic charges!

6.3 Connection example

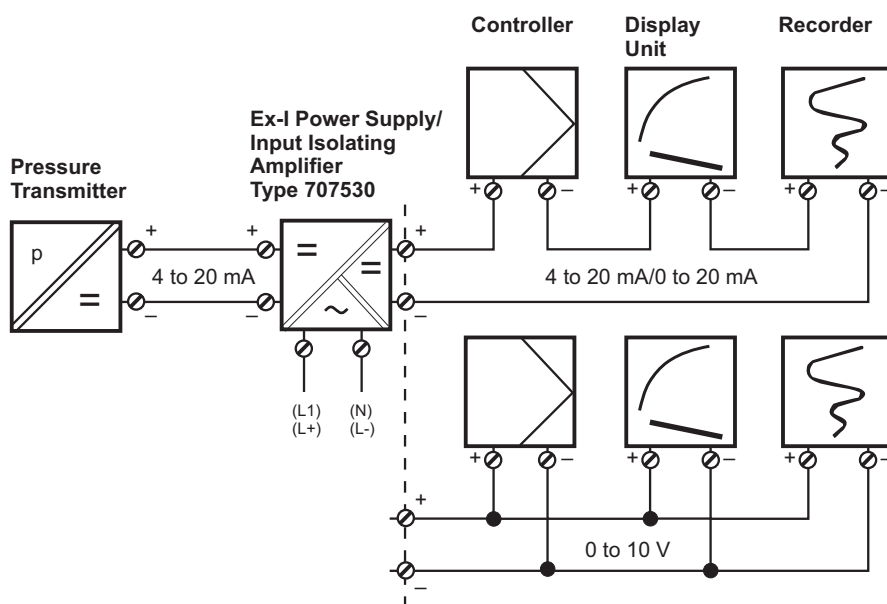

7 Maintenance, cleaning, returns, disposal

7.1 Maintenance

The pressure transmitter is maintenance-free.

7.2 Cleaning



NOTE!

Avoid damage to the device due to improper cleaning.

Do not damage the pressure transmitter, in particular the parts that come into contact with media. The cleaning agent must not attack the surface or seals.

7.3 Returns



WARNING!

Injury to persons, damage to property, environmental damage

Measured material residues on the removed product can cause injury to humans, and damage to the environment and equipment.

- ▶ Take sufficient precautionary measures.
-



NOTE!

All information necessary for return is included in the [Supplementary sheet for product returns](#).



NOTE!

The product may only be disassembled in a safe, de-pressurized, and zero-voltage state by qualified personnel.

7.4 Disposal



- Do not dispose of the device or replaced parts in the trash after use.
- Delete programs and data stored on the device.
- Remove batteries, if any, if this can be done without damaging the device.
- Dispose of the device and the packaging material in a responsible and environmentally friendly manner.
- Observe the country-specific laws and regulations for waste treatment and disposal.

In accordance with Directive 2012/19/EU on Waste from Electrical and Electronic Equipment, manufacturers are obliged to offer the option of returning waste equipment. Request the return from the manufacturer.

JUMO GmbH & Co. KG

Moritz-Juchheim-Straße 1
36039 Fulda, Germany

Tel.: +49 661 6003-0
Fax: +49 661 6003-500

E-Mail: mail@jumo.net
Internet: www.jumo.net



More than **sensors + automation**

EU-Konformitätserklärung

EU declaration of conformity / Déclaration UE de conformité

Dokument-Nr. CE 695
Document No. / Document n°.

Hersteller JUMO GmbH & Co. KG
Manufacturer / Etabli par

Anschrift Moritz-Juchheim-Straße 1, 36039 Fulda, Germany
Address / Adresse

Produkt

Product / Produit

| Name | Typ | Typenblatt-Nr. |
|-------------------|--------------------|--|
| <i>Name / Nom</i> | <i>Type / Type</i> | <i>Data sheet no. / N° Document d'identification</i> |
| JUMO MIDAS S21 Ex | 404710 | 404710 |

Produktbeschreibung

Product description / Description du produit

Industrial pressure transmitter.

Wir erklären in alleiniger Verantwortung, dass das bezeichnete Produkt die Anforderungen der Europäischen Richtlinien erfüllt.

We hereby declare in sole responsibility that the designated product fulfills the requirements of the European Directives.

Nous déclarons sous notre seule responsabilité que le produit remplit les Directives Européennes.

Dokument-Nr.
Document No. / Document n°.

CE 695

EU-Konformitätserklärung

Seite: 1 von 5

8 Certificates

JUMO GmbH & Co. KG

Moritz-Juchheim-Straße 1
36039 Fulda, Germany

Tel.: +49 661 6003-0
Fax: +49 661 6003-500

E-Mail: mail@jumo.net
Internet: www.jumo.net



More than sensors + automation

1. Richtlinie

Directive / Directive

Name

EMC 2014/30/EU

Name / Nom

Konformitätsbewertungsverfahren

Mod. A

Conformity assessment procedure /

Procédure d'évaluation de la conformité

Datum der Erstanbringung des CE-Zeichens auf dem Produkt

2009

Date of first application of the CE mark to the product /

Date de 1ère application du sigle sur le produit

Angewendete Normen/Spezifikationen

Standards/Specifications applied / Normes/Spécifications appliquées

Referenz

Reference / Référence

Ausgabe

Edition / Édition

Bemerkung

Comment / Remarque

EN 61326-1

2013

EN 61326-2-3

2013

Gültig für Typ

Valid for Type / Valable pour le type

404710/...

2. Richtlinie

Directive / Directive

Name

ATEX 2014/34/EU

Name / Nom

Konformitätsbewertungsverfahren

Mod. B+D

Conformity assessment procedure /

Procédure d'évaluation de la conformité

Datum der Erstanbringung des CE-Zeichens auf dem Produkt

2009

Date of first application of the CE mark to the product /

Date de 1ère application du sigle sur le produit

Dokument-Nr.

Document No. / Document n°.

CE 695

EU-Konformitätserklärung

Seite: 2 von 5

JUMO GmbH & Co. KG

Moritz-Juchheim-Straße 1
36039 Fulda, Germany

Tel.: +49 661 6003-0
Fax: +49 661 6003-500

E-Mail: mail@jumo.net
Internet: www.jumo.net



More than **sensors + automation**

Angewendete Normen/Spezifikationen

Standards/Specifications applied / Normes/Spécifications appliquées

| Referenz <i>Reference / Référence</i> | Ausgabe <i>Edition / Édition</i> | Bemerkung <i>Comment / Remarque</i> |
|--|-------------------------------------|--|
| EN 60079-0 | 2018 | |
| EN 60079-11 | 2012 | |

Gültig für Typ

Valid for Type / Valable pour le type

404710/000-* -405-* -20-...

2.1 EU-Baumusterprüfbescheinigung

EU type examination certificate / Certificat d'examen de type UE

Zertifikatsnummer SEV 09 ATEX 0101 X Ausgabe 1
Certificate number / Numéro de certificat

Notifizierte Stelle Eurofins Electric & Electronic Product Testing
Notified Body / Organisme notifié AG, Luppmenstrasse 3, 8320 Fehraltdorf,
Switzerland

Angewendete Normen/Spezifikationen

Standards/Specifications applied / Normes/Spécifications appliquées

| Referenz <i>Reference / Référence</i> | Ausgabe <i>Edition / Édition</i> | Bemerkung <i>Comment / Remarque</i> |
|--|-------------------------------------|--|
| EN 60079-0 | 2018 | |
| EN 60079-11 | 2012 | |

Qualitätssicherung bezogen auf den Produktionsprozess

Quality assurance of the production process / L'assurance de la qualité de la production

Zertifikatsnummer Available on request
Certificate number / Numéro de certificat

Notifizierte Stelle BUREAU VERITAS Consumer Products
Notified Body / Organisme notifié Services Germany GmbH, Wilhelm-Hennemann-
Straße 8, 19061 Schwerin, Germany

Kennnummer 2004
Identification no. / N° d'identification

Dokument-Nr.
Document No. / Document n°.

CE 695

EU-Konformitätserklärung

Seite: 3 von 5

8 Certificates

JUMO GmbH & Co. KG

Moritz-Juchheim-Straße 1
36039 Fulda, Germany

Tel.: +49 661 6003-0
Fax: +49 661 6003-500

E-Mail: mail@jumo.net
Internet: www.jumo.net



More than sensors + automation

3. Richtlinie

Directive / Directive

Name RoHS 2011/65/EU

Name / Nom

Konformitätsbewertungsverfahren Mod. A

Conformity assessment procedure /

Procédure d'évaluation de la conformité

Datum der Erstanbringung des CE-Zeichens auf dem Produkt 2017

Date of first application of the CE mark to the product /

Date de 1ère application du sigle sur le produit

Angewendete Normen/Spezifikationen

Standards/Specifications applied / Normes/Spécifications appliquées

Referenz

Reference / Référence

Ausgabe

Edition / Édition

Bemerkung

Comment / Remarque

VDK Umweltrelevante Aspekte V1

bei der Produktentwicklung und
-gestaltung

Gültig für Typ

Valid for Type / Valable pour le type

404710/...

Dokument-Nr.
Document No. / Document n°.

CE 695

EU-Konformitätserklärung

Seite: 4 von 5

JUMO GmbH & Co. KG

Moritz-Juchheim-Straße 1
36039 Fulda, Germany

Tel.: +49 661 6003-0
Fax: +49 661 6003-500

E-Mail: mail@jumo.net
Internet: www.jumo.net



More than **sensors + automation**

Aussteller

Issued by / Etabli par

JUMO GmbH & Co. KG

Ort, Datum

Place, date / Lieu, date

Fulda, 2023-05-10

Rechtsverbindliche Unterschriften

Legally binding signatures /

Signatures juridiquement valable

Bereichsleitung Globaler Vertrieb

i. V. Markus Belmer

Qualitätsbeauftragter und Leiter Qualitätswesen

i. V. Harald Gienger

8 Certificates



(1) **EU-Type Examination Certificate**

- (2) Equipment or protective system intended for use in potentially explosive atmospheres - **Directive 2014/34/EU**
- (3) Certificate number: **SEV 09 ATEX 0101 X**
- (4) Product: Pressure transducer
Type JUMO MIDAS S21 Ex 404710 / 000 - *** - 405 - *** - 20 - **
- (5) Manufacturer: JUMO GmbH & Co. KG
- (6) Address: Moritz-Juchheim-Strasse 1, 36039 Fulda, Germany
- (7) The equipment and any acceptable variation thereto is specified in the schedule to this certificate and the documents therein referred to.
- (8) Eurofins, notified body No. 1258, in accordance with article 17 of Directive 2014/34/EU of the European parliament and of the council, dated 26 February 2014, certifies that this product has been found to comply with the essential health and safety requirements relating to the design and construction of products intended for use in potentially explosive atmospheres given in Annex II to the Directive.
The examination and test results are recorded in confidential report no 19CH-01050.X02
- (9) Compliance with the essential health and safety requirements has been assured by compliance with:
EN IEC 60079-0:2018
EN 60079-11:2012
Except in respect of those requirements listed at item 18 of the schedule.
- (10) If the sign «X» is placed after the certificate number, it indicates that the product is subjected to special conditions for safe use specified in the schedule to this certificate. The sign "U" is placed after the certificate number. It indicates that this certificate must not be mistaken for a certificate intended for an equipment or protective system. This partial certification may be used as a basis for certification of an equipment or protective system.
- (11) This EU type examination certificate relates only to design and construction of the specified product. Further requirements of this directive apply to the manufacturing process and supply of this product. These are not covered by this certificate.
- (12) The marking of the product shall include the following:

 II 2G Ex ib IIC T6 ... T4 Gb
II 2D Ex ib IIIC T70 °C ... T100 °C Db

Eurofins Electric & Electronic Product Testing AG
Notified Body ATEX

Martin Plüss
Product Certification

www.eurofins.ch

Fehraltorf, 2021-04-20

Issue: 1

Page 1 of 4

T8a_V01



(13)

Appendix

(14)

EU-Type Examination Certificate no. SEV 09 ATEX 0101 X

(15) **Description of product**

The pressure transducer JUMO MIDAS S21 Ex type 404710 / 000 - *** - 405 - *** - 20 - ** serves for converting a physical measured quantity (pressure) into a standardised electrical signal (current signal 4 .. 20 mA). It is intended for use within potentially explosive areas.

The intrinsically safe circuit is connected with a non-detachable (cable length in plain text), circular connector M12 x 1 or a special electrical connection.

Measuring and supply circuit with the type of protection intrinsic safety

Ex ib IIC

Ex ib IIIC

Only for connection to a certified intrinsically safe circuit.

Rating:

Input and supply circuits:

With type of protection intrinsic safety Ex ib IIC

Only for connection to certified intrinsically safe circuit.

Maximum values for circular connector M12x1 and special electrical connection:

$U_i \leq 28 \text{ V}$

$i_i \leq 100 \text{ mA}$

$P_i \leq 750 \text{ mW}$

$C_i = 10.4 \text{ nF}$ (effective internal capacitance)

$L_i = 0 \text{ uH}$ (effective internal inductance)

Maximum values for electrical connection with non-detachable cable:

$U_i \leq 28 \text{ V}$

$i_i \leq 100 \text{ mA}$

$P_i \leq 750 \text{ mW}$

$C_i \leq 10.4 \text{ nF} + 100 \text{ pF/m} \cdot \text{cable length}$

$L_i \leq 1 \text{ uH/m} \cdot \text{cable length}$

Classification of installation and use:

stationary

Ingress protection:

IP65

Equipment protection level Gb

Ambient temperature:

T4: -40 °C to +85 °C

T5: -40 °C to +70 °C

T6: -40 °C to +55 °C

Rated ambient temperature range (°C):

Equipment protection level Db

maximum surface temperature:

T100 °C: -40 °C to +85 °C

T85 °C: -40 °C to +70 °C

T70 °C: -40 °C to +55 °C

8 Certificates



Type designation:

Example of type designation 404710/000 - 459 - 405 - 504 - 20 - 11 / 000
(1) (2) (3) (4) (5) (6) (7)

(1) Basic type

404710/000 JUMO MIDAS S21 Ex – Pressure transducer for use in potentially explosive atmospheres

(2)* Pressure rated measuring range

432 0 to 30 bar relative pressure
451 0 to 0.25 bar relative pressure
452 0 to 0.4 bar relative pressure
453 0 to 0.6 bar relative pressure
454 0 to 1 bar relative pressure
455 0 to 1.6 bar relative pressure
456 0 to 2.5 bar relative pressure
457 0 to 4 bar relative pressure
458 0 to 6 bar relative pressure
459 0 to 10 bar relative pressure
460 0 to 16 bar relative pressure
461 0 to 25 bar relative pressure
462 0 to 40 bar relative pressure
463 0 to 60 bar relative pressure
464 0 to 100 bar relative pressure
475 -0.25 to 0 bar relative pressure
476 -0.4 to 0 bar relative pressure
477 -0.6 to 0 bar relative pressure
478 -1 to 0 bar relative pressure
479 -1 to +0.6 bar relative pressure
480 -1 to +1.5 bar relative pressure
481 -1 to +3 bar relative pressure
482 -1 to +5 bar relative pressure
483 -1 to +9 bar relative pressure
484 -1 to +15 bar relative pressure
485 -1 to +24 bar relative pressure
487 0 to 0.6 bar absolute pressure
488 0 to 1 bar absolute pressure
489 0 to 1.6 bar absolute pressure
490 0 to 2.5 bar absolute pressure
491 0 to 4 bar absolute pressure
492 0 to 6 bar absolute pressure
493 0 to 10 bar absolute pressure
494 0 to 16 bar absolute pressure
495 0 to 25 bar absolute pressure
998 special measuring range for absolute pressure
999 special measuring range for relative pressure

(3) Electrical output

405 4 to 20 mA. two-wire

(4)* Process connection

502 G 1/4 according to DIN EN 837
504 G 1/2 according to DIN EN 837
511 1/4-18 NPT according to DIN EN 837
512 1/2-14 NPT according to DIN EN 837
521 G 1/4 according to DIN 3852-11
523 G 1/2 according to DIN 3852-11
563 7/16-20 UNF inside with vent core pusher
583 M20 x 1.5 with stud
999 according to customer specification

(5) Material of process connection

20 CrNi (stainless steel)

(6) Electrical connection

11 attached cable
24 loose stranded wires
36 round plug M12x1
61 cable socket DIN EN 175301-803 form A
99 special electrical connection

(7)* Additional options

000 without
462 inverted output signal
591 choking coil in pressure channel
624 free from oil and grease
630 widened pressure channel

*) The numerical type keys can be extended with values not named here in the sense of the basic test. These extensions have no effect on the explosion protection and general safety.





(16) **Specific conditions of use**

- For details concerning the admissible ambient temperatures and temperature classes please refer to the user's manual.
- The sensor with the connector cable socket (NTS 61) may only be used for gas applications.

(17) **Essential health and safety requirements**

In addition to the essential health and safety requirements (EHSRs) covered by the standards listed at item 9, the following are considered relevant to this product, and conformity is demonstrated in the report:

| Clause | Subject |
|--------|---------|
| None | |

(18) **Drawings and Documents**

See test report "Manufacturer's Documents"



8 Certificates

JUMO GmbH & Co. KG

Moritz-Juchheim-Straße 1
36039 Fulda, Germany

Tel.: +49 661 6003-0
Fax: +49 661 6003-500

E-Mail: mail@jumo.net
Internet: www.jumo.net



More than sensors + automation

UK Declaration of Conformity

Document No. UK 201
Manufacturer JUMO GmbH & Co. KG
Address Moritz-Juchheim-Straße 1, 36039 Fulda, Germany

Product
Name JUMO MIDAS S21 Ex
Type 404710
Data sheet no. 404710

Product description
Pressure transmitter for use in Ex areas.

We hereby declare in sole responsibility that the designated product fulfills the requirements of the statutory instruments.

1. Statutory instrument

Name Electromagnetic Compatibility Regulations 2016
No. 1091
Conformity assessment procedure Mod. A
Date of first application of the UKCA mark to the product 2023

Standards/Specifications applied

| Reference | Edition | Comment |
|--------------|---------|---------|
| EN 61326-1 | 2013 | |
| EN 61326-2-3 | 2013 | |

Valid for Type
404710/...

Document No. UK 201 UK Declaration of Conformity Seite: 1 von 3

JUMO GmbH & Co. KG

Moritz-Juchheim-Straße 1
36039 Fulda, Germany

Tel.: +49 661 6003-0
Fax: +49 661 6003-500

E-Mail: mail@jumo.net
Internet: www.jumo.net



More than **sensors + automation**

2. Statutory instrument

Name The Restriction of the Use of Certain Hazardous Substances in Electrical and Electronic Equipment Regulations 2012 No. 3032

Conformity assessment procedure Mod. A

Date of first application of the UKCA mark to the product 2023

Standards/Specifications applied

| Reference | Edition | Comment |
|---|---------|---------|
| [VDK] Umweltrelevante Aspekte V1 bei der Produktentwicklung und -gestaltung | | |

Valid for Type

404710/...

3. Statutory instrument

Name The Equipment and Protective Systems Intended for Use in Potentially Explosive Atmospheres Regulations 2016 No. 1107

Conformity assessment procedure Mod. B+D

Date of first application of the UKCA mark to the product 2023

Standards/Specifications applied

| Reference | Edition | Comment |
|-------------|---------|---------|
| EN 60079-0 | 2018 | |
| EN 60079-11 | 2012 | |

Valid for Type

404710/...

Document No.

UK 201

UK Declaration of Conformity

Seite: 2 von 3

8 Certificates

JUMO GmbH & Co. KG

Moritz-Juchheim-Straße 1
36039 Fulda, Germany

Tel.: +49 661 6003-0
Fax: +49 661 6003-500

E-Mail: mail@jumo.net
Internet: www.jumo.net



More than **sensors + automation**

3.1 Type examination certificate

Certificate number

EPS 22 UKEX 1 088 X

Designated body

Bureau Veritas Consumer Products Services
United Kingdom Limited, 31 Kingsland Grange,
Woolston, Warrington, Cheshire, WA1 4RW

Quality assurance of the production process**Certificate number**

Available on request.

Designated body

Bureau Veritas Consumer Products Services
United Kingdom Limited, 31 Kingsland Grange,
Woolston, Warrington, Cheshire, WA1 4RW

Identification no.

8507

Issued by

JUMO GmbH & Co. KG

Place, date

Fulda, 2023-08-07

Legally binding signatures

Director of Global Sales
Markus Belmer

Head of Quality Department

Harald Gienger



- (1) **UK - Type Examination Certificate**
- (2) Equipment and protective systems intended for use in potentially explosive atmospheres – **UKSI 2016:1107 (as amended)**
- (3) UK - Type Examination Certificate Number
EPS 22 UKEX 1 088 X **Revision 0**
- (4) Equipment: Pressure transducer JUMO MIDAS S21 Ex 404710 / 000 - *** - 405 - *** - 20 - **
- (5) Manufacturer: JUMO GmbH & Co. KG
- (6) Address: Moritz-Juchheim-Straße 1
 36039 Fulda
 Germany
- (7) This equipment and any acceptable variation thereto are specified in the annex to this certificate and the documentation therein referred to.
- (8) Bureau Veritas Consumer Products Services United Kingdom Limited, approved body No. 8507 in accordance with UKSI 2016:1107 (as amended) Part 4, certifies that this equipment has been found to comply with the essential health and safety requirements relating to the design and construction of equipment and protective systems intended for use in potentially explosive atmospheres, given in Schedule 1 of UKSI 2016:1107 (as amended). The examination and test results are recorded in the confidential documentation under the reference number 22TH0288.
- (9) Compliance with the essential health and safety requirements has been assured by compliance with:
EN IEC 60079-0:2018 **EN 60079-11:2012**
- (10) If the sign "X" is placed after the certificate number, it indicates that the equipment is subject to special conditions for safe use specified in the annex to this certificate.
- (11) This UK - Type Examination Certificate relates only to the design and construction of the specified equipment in accordance with UKSI 2016:1107 (as amended). Further requirements apply to the manufacture of this equipment and its placing on the market. Those requirements are not covered by this certificate.
- (12) The marking of the equipment shall include the following:

II 2G Ex ib IIC T4...T6 Gb
 II 2D Ex ib IIIC T70°C...T100°C Db



Certification department of explosion protection

Warrington, 31-07-2023

N. Wilkinson
 Natalie Wilkinson



Certificates without signature and seal are void. This certificate is allowed to be distributed only if not modified. Extracts or modifications must be authorized by Bureau Veritas Consumer Products Services United Kingdom Limited. EPS 22 UKEX 1 088 X, Revision 0.

Bureau Veritas Consumer Products Services United Kingdom Limited
<https://www.bureauveritas.co.uk/consumer-products-testing>
 +44 (0) 1925 854 360

Registered Office: 31 Kingsland Grange,
 Woolston, Warrington, Cheshire, WA1 4RW

Registered in England & Wales
 Company Number: 00852439

ZERT-0003-GBR-ZE-EX-V03 / TEMP-0005-GBR-ZE-EX-V01

1/4

8 Certificates



(13)

Annex

(14) **UK - Type Examination Certificate EPS 22 UKEX 1 088 X**

Revision 0

(15) Description of equipment:

The pressure transducer JUMO MIDAS S21 Ex type 404710 / 000 - *** - 405 - *** - 20 - ** serves for converting a physical measured quantity (pressure) into a standardized electrical signal (current signal 4 ... 20 mA). It is intended for use within potentially explosive areas.

The intrinsically safe circuit is connected with a non-detachable (cable length in plain text), circular connector M12x1 or a special electrical connection.

Measuring and supply circuit with the type of protection intrinsic safety

Ex ib IIC
Ex ib IIIC

Only for connection to a certified intrinsically safe circuit.

Rating:

Input and supply circuits:

With type of protection intrinsic safety Ex ib IIC

Only for connection to certified intrinsically safe circuit.

Maximum values for circular connector M12x1 and special electrical connection:

$U_i \leq 28 \text{ V}$
 $I_i \leq 100 \text{ mA}$
 $P_i \leq 750 \text{ mW}$
 $C_i \leq 10.4 \text{ nF}$ (effective internal capacitance)
 $L_i \approx 0 \text{ uH/m}$ (effective internal inductance)

Maximum values for electrical connection with non-detachable cable:

$U_i \leq 28 \text{ V}$
 $I_i \leq 100 \text{ mA}$
 $P_i \leq 750 \text{ mW}$
 $C_i \leq 10.4 \text{ nF} + 100 \text{ pF/m} \cdot \text{cable length}$
 $L_i \leq 1 \text{ uH/m} \cdot \text{cable length}$

Type designation:

Example of type designation 404710/000 - 459 - 405 - 504 - 20 - 11 / 000

(1) (2) (3) (4) (5) (6) (7)

(1) Basic type

404710/000 JUMO MIDAS S21 Ex – Pressure transducer for use in potentially explosive atmospheres

Certificates without signature and seal are void. This certificate is allowed to be distributed only if not modified. Extracts or modifications must be authorized by Bureau Veritas Consumer Products Services United Kingdom Limited. EPS 22 UKEX 1 088 X, Revision 0.

Bureau Veritas Consumer Products Services United Kingdom Limited
<https://www.bureauveritas.co.uk/consumer-products-testing>
+44 (0) 1925 854 360

Registered Office: 31 Kingsland Grange,
Woolston, Warrington, Cheshire, WA1 4RW

Registered in England & Wales
Company Number: 00852439

ZERT-0003-GBR-ZE-EX-V03 / TEMP-0005-GBR-ZE-EX-V01

2/4



UK - Type Examination Certificate EPS 22 UKEX 1 088 X

Revision 0

(2)* Pressure rated measuring range

- 432 0 to 30 bar relative pressure
- 451 0 to 0.25 bar relative pressure
- 452 0 to 0.4 bar relative pressure
- 453 0 to 0.6 bar relative pressure
- 454 0 to 1 bar relative pressure
- 455 0 to 1.6 bar relative pressure
- 456 0 to 2.5 bar relative pressure
- 457 0 to 4 bar relative pressure
- 458 0 to 6 bar relative pressure
- 459 0 to 10 bar relative pressure
- 460 0 to 16 bar relative pressure
- 461 0 to 25 bar relative pressure
- 462 0 to 40 bar relative pressure
- 463 0 to 60 bar relative pressure
- 464 0 to 100 bar relative pressure
- 475 -0.25 to 0 bar relative pressure
- 476 -0.4 to 0 bar relative pressure
- 477 -0.6 to 0 bar relative pressure
- 478 -1 to 0 bar relative pressure
- 479 -1 to +0.6 bar relative pressure
- 480 -1 to +1.5 bar relative pressure
- 481 -1 to +3 bar relative pressure
- 482 -1 to +5 bar relative pressure
- 483 -1 to +9 bar relative pressure
- 484 -1 to +15 bar relative pressure
- 485 -1 to +24 bar relative pressure
- 487 0 to 0.6 bar absolute pressure
- 488 0 to 1 bar absolute pressure
- 489 0 to 1.6 bar absolute pressure
- 490 0 to 2.5 bar absolute pressure
- 491 0 to 4 bar absolute pressure
- 492 0 to 6 bar absolute pressure
- 493 0 to 10 bar absolute pressure
- 494 0 to 16 bar absolute pressure
- 495 0 to 25 bar absolute pressure
- 998 special measuring range for absolute pressure
- 999 special measuring range for relative pressure

(3) Electrical output

- 405 4 to 20 mA, two-wire

(4)* Process connection

- 502 G 1/4 according to DIN EN 837
- 504 G 1/2 according to DIN EN 837
- 511 1/4-18 NPT according to DIN EN 837
- 512 1/2-14 NPT according to DIN EN 837
- 521 G 3/4 according to DIN 3852-11
- 523 G 1/2 according to DIN 3852-11
- 563 7/16-20 UNF inside with vent core pusher
- 583 M20 x 1.5 with stud
- 999 according to customer specification

(5) Material of process connection

- 20 CrNi (stainless steel)

Certificates without signature and seal are void. This certificate is allowed to be distributed only if not modified. Extracts or modifications must be authorized by Bureau Veritas Consumer Products Services United Kingdom Limited, EPS 22 UKEX 1 088 X, Revision 0.

Bureau Veritas Consumer Products Services United Kingdom Limited
<https://www.bureauveritas.co.uk/consumer-products-testing>
 +44 (0) 1925 854 360

Registered Office: 31 Kingsland Grange,
 Woolston, Warrington, Cheshire, WA1 4RW

Registered in England & Wales
 Company Number: 00852439

ZERT-0003-GBR-ZE-EX-V03 / TEMP-0005-GBR-ZE-EX-V01

3/4

8 Certificates



UK - Type Examination Certificate EPS 22 UKEX 1 088 X

Revision 0

(6) Electrical connection

- 11 attached cable
- 24 lose stranded wires
- 36 round plug M12×1
- 61 cable socket DIN EN 175301-803 form A
- 99 special electrical connection

(7)* Additional options

- 000 without
- 462 inverted output signal
- 591 choking coil in pressure channel
- 624 free from oil and grease
- 630 widened pressure channel

*) The numerical type keys can be extended with values not named here in the sense of the basic test. These extensions have no effect on the explosion protection and general safety.

(16) Reference number: 22TH0288

(17) Special conditions for safe use:

For details concerning the admissible ambient temperatures and temperature classes please refer to the user's manual.

The sensor with the connector cable socket (NTS 61) may only be used for gas applications.

(18) Essential health and safety requirements:

Met by compliance with standards.

Certification department of explosion protection

Warrington, 31-07-2023



Natalie Wilkinson

Certificates without signature and seal are void. This certificate is allowed to be distributed only if not modified. Extracts or modifications must be authorized by Bureau Veritas Consumer Products Services United Kingdom Limited, EPS 22 UKEX 1 088 X, Revision 0.

Bureau Veritas Consumer Products Services United Kingdom Limited
<https://www.bureauveritas.co.uk/consumer-products-testing>
+44 (0) 1925 854 360

Registered Office: 31 Kingsland Grange,
Woolston, Warrington, Cheshire, WA1 4RW

Registered in England & Wales
Company Number: 00852439

ZERT-0003-GBR-ZE-EX-V03 / TEMP-0005-GBR-ZE-EX-V01

4/4

|  产品组别 Product group: 404710 | | 产品中有害物质的名称及含量 China EEP Hazardous Substances Information | | | | | | |
|--|--|---|-----------|-----------|-----------------|---------------|-----------------|--|
| | | Component Name | | | | | | |
| 部件名称 Component Name | | 铅 (Pb) | 汞 (Hg) | 镉 (Cd) | 六价铬 (Cr(VI)) | 多溴联苯 (PBB) | 多溴二苯醚 (PBDE) | |
| 外壳 Housing (Gehäuse) | | ○ | ○ | ○ | ○ | ○ | ○ | |
| 过程连接 Process connection (Prozessanschluss) | | X | ○ | ○ | ○ | ○ | ○ | |
| 螺母 Nuts (Mutter) | | ○ | ○ | ○ | ○ | ○ | ○ | |
| 螺栓 Screw (Schraube) | | ○ | ○ | ○ | ○ | ○ | ○ | |

本表格依据SJ/T 11364的规定编制。
 This table is prepared in accordance with the provisions SJ/T 11364.
 ○：表示该有害物质在该部件所有均质材料中的含量均在GB/T 26572规定的限量要求以下。
 Indicate the hazardous substances in all homogeneous materials' for the part is below the limit of the GB/T 26572.
 x：表示该有害物质至少在该部件的某一均质材料中的含量超出GB/T 26572规定的限量要求。
 Indicate the hazardous substances in at least one homogeneous materials' of the part is exceeded the limit of the GB/T 26572.

8 Certificates



JUMO GmbH & Co. KG

Street address:
Moritz-Juchheim-Straße 1
36039 Fulda, Germany

Delivery address:
Mackenrodtstraße 14
36039 Fulda, Germany

Postal address:
36035 Fulda, Germany

Phone: +49 661 6003-0
Fax: +49 661 6003-607
Email: mail@jumo.net
Internet: www.jumo.net

JUMO UKL TD

JUMO House
Temple Bank, Riverway
Harlow, Essex, CM20 2DY, UK

Phone: +44 1279 63 55 33
Fax: +44 1279 62 50 29
Email: sales@jumo.co.uk
Internet: www.jumo.co.uk

JUMO Process Control, Inc.

6724 Joy Road
East Syracuse, NY 13057, USA

Phone: +1 315 437 5866
Fax: +1 315 437 5860
Email: info.us@jumo.net
Internet: www.jumousa.com



JUMO MIDAS S21 Ex

Convertisseur de pression pour utilisation en zone Ex



Notice de mise en service



40471000T90Z000K000

FR/2024-05-15

Informations complémentaires et téléchargements



qr-404710-fr.jumo.info

| | | |
|----------|--|-----------|
| 1 | Instructions relatives à la sécurité | 4 |
| 1.1 | Symboles d'avertissement | 4 |
| 1.2 | Symboles indiquant une remarque | 4 |
| 1.3 | Mélanges hybrides | 4 |
| 2 | Introduction | 5 |
| 3 | Identification de l'exécution de l'appareil | 7 |
| 3.1 | Plaque signalétique | 7 |
| 3.2 | Références de commande | 7 |
| 3.3 | Matériel livré | 9 |
| 3.4 | Accessoires | 9 |
| 4 | Caractéristiques techniques | 10 |
| 4.1 | Généralités | 10 |
| 4.2 | Entrée | 10 |
| 4.2.1 | Etendue de mesure et précision | 10 |
| 4.3 | Sortie | 11 |
| 4.4 | Caractéristiques mécaniques | 11 |
| 4.5 | Influences de l'environnement | 11 |
| 4.6 | Caractéristiques électriques | 12 |
| 4.7 | Homologations et marques de contrôle | 13 |
| 5 | Montage | 14 |
| 5.1 | Généralités | 14 |
| 5.2 | Raccord de pression | 15 |
| 5.3 | Dimensions | 16 |
| 5.3.1 | Raccordement électrique | 16 |
| 5.3.2 | Raccords de process | 18 |
| 6 | Installation | 20 |
| 6.1 | Raccordement électrique | 20 |
| 6.2 | Schéma de raccordement | 21 |
| 6.3 | Exemple de raccordement | 21 |
| 7 | Entretien, nettoyage, retour, mise, rebut | 22 |
| 7.1 | Maintenance | 22 |
| 7.2 | Nettoyage | 22 |
| 7.3 | Retour | 22 |
| 7.4 | Traitement des déchets | 22 |
| 8 | Certificats | 23 |

1 Instructions relatives à la sécurité

1.1 Symboles d'avertissement



DANGER!

Ce pictogramme signale que la non-observation des mesures de précaution peut provoquer des **dommages corporels par électrocution**.



AVERTISSEMENT!

Ce pictogramme est utilisé lorsque la non-observation ou l'observation imprécise des instructions peut provoquer des **dommages corporels ou un décès par électrocution**.



ATTENTION!

Ce pictogramme associé à un mot clé signale que si l'on ne prend pas des mesures adéquates, cela provoque des **dégâts matériels ou des pertes de données**.



ATTENTION!

Ce pictogramme signale que si l'on ne prend pas des mesures adéquates des **composants peuvent être détruits** par décharge électrostatique (ESD = Electro Static Discharge).

Si vous retournez des châssis, des modules ou des composants, n'utilisez que les emballages ESD prévus à cet effet.



LISEZ LA DOCUMENTATION !

Ce pictogramme – posé sur l'appareil – signale que la **documentation appareil** doit être **respectée**. Ceci est nécessaire, pour reconnaître la nature des risques potentiels et les mesures à prendre pour les éviter.

1.2 Symboles indiquant une remarque



REMARQUE !

Ce pictogramme renvoie à une **information importante** sur le produit, sur son maniement ou ses applications annexes.



Renvoi !

Ce pictogramme renvoie à des **informations supplémentaires** dans d'autres sections, chapitres ou notices.

1.3 Mélanges hybrides

Les mélanges hybrides sont des mélanges explosibles composés de gaz combustibles, de vapeurs ou brouillards avec poussières combustibles. Le matériel destiné à des atmosphères explosives, en présence de mélanges hybrides, doit être particulièrement contrôlé pour cette application. Il incombe à l'exploitant de vérifier que le matériel est adapté à de telles applications.



DANGER!

Veillez tenir compte de la Déclaration CE de conformité, de l'Attestation d'examen CE de type (à la fin de cette notice de mise en service) ainsi que des instructions relatives aux capteurs en atmosphères explosibles !

Selon l'exécution, les capteurs ne peuvent être utilisés que dans des circuits à sécurité intrinsèque.

- ▶ Les valeurs admissibles sont énumérées dans l'attestation.
-

Généralités

Le convertisseur de pression mesure la pression de gaz, de vapeurs et de liquides. Il fonctionne suivant le principe de mesure piézorésistif. Le signal de sortie est un courant continu contraint, proportionnel (de façon linéaire) à la pression d'entrée.

Le convertisseur de pression, type 404710 satisfait les exigences

- du groupe d'explosion II dans les atmosphères explosibles des zones 1 et 2
- du groupe d'explosion III dans les atmosphères explosibles des zones 21 et 22

Le certificat d'examen de type CE du convertisseur de pression est :

SEV 09 ATEX 0101 X



ATTENTION!

La membrane du convertisseur de pression ne doit pas être endommagée !

Les mesures suivantes doivent être respectées :

- Ne pas introduire d'objet dans le perçage du raccord de pression !
- Ne pas diriger de jet de pression sur la membrane !
- La membrane ne doit pas être déformée. Toucher la membrane avec les doigts suffit pour l'endommager.
- La pression à mesurer ne doit pas dépasser, même en cas de pointes de pression, la surpression autorisée. Des pointes de pression élevées (coup de bélier) peuvent détruire le convertisseur de pression. Dans ces conditions, il faut prendre toutes les mesures préventives nécessaires (par ex. monter un élément amortisseur).

2 Introduction

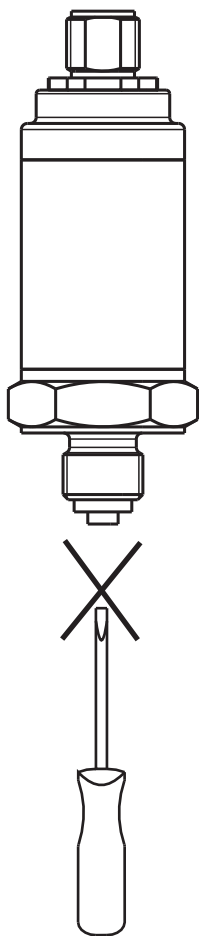

ATTENTION!

Pour éviter des détériorations sur le convertisseur de pression et sécuriser vos process, le montage, l'installation et la mise en service ne doivent être effectués que par du personnel qualifié. Ce personnel doit connaître les règlements locaux ainsi que les normes et directives applicables pour éviter les dommages corporels et les dégâts matériels.

- ▶ Le personnel spécialisé doit lire la notice de mise en service ainsi que la plaque signalétique et les avoir comprises de telle sorte qu'il peut suivre les instructions. Les modifications et les réparations ne peuvent être effectuées que si elles sont autorisées dans la notice de mise de service. Conservez cette notice de mise en service dans un endroit accessible à tout moment à tous les utilisateurs.

3 Identification de l'exécution de l'appareil

3.1 Plaque signalétique

Exemple :

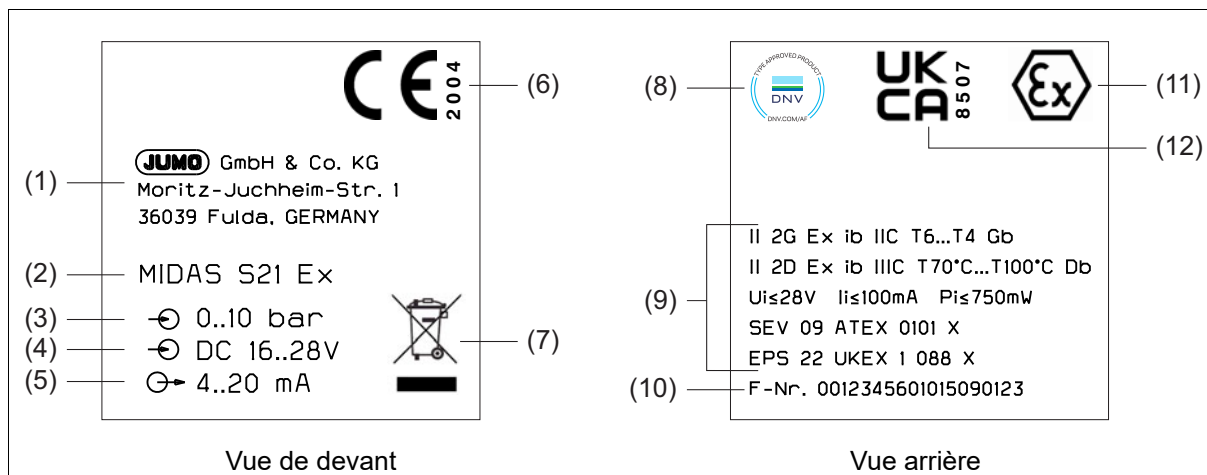

- | | | | |
|---|---------------------------|----|------------------------|
| 1 | Fabricant et adresse | 7 | Traitement des déchets |
| 2 | Désignation de l'appareil | 8 | Marquage DNV |
| 3 | Etendue de mesure | 9 | Indications Ex |
| 4 | Alimentation | 10 | Numéro de série |
| 5 | Sortie | 11 | Marquage Ex |
| 6 | Marquage CE | 12 | Marquage UKCA |

3.2 Références de commande

| (1) Type de base | |
|---------------------------------------|---|
| 404710/000 | JUMO MIDAS S21 Ex – Convertisseur de pression pour utilisation en zone Ex |
| (2) Entrée Etendue de mesure nominale | |
| 451 | 0 à 0,25 bar pression relative |
| 452 | 0 à 0,4 bar pression relative |
| 453 | 0 à 0,6 bar pression relative |
| 454 | 0 à 1 bar pression relative |
| 455 | 0 à 1,6 bar pression relative |
| 456 | 0 à 2,5 bar pression relative |
| 457 | 0 à 4 bar pression relative |
| 458 | 0 à 6 bar pression relative |
| 459 | 0 à 10 bar pression relative |
| 460 | 0 à 16 bar pression relative |
| 461 | 0 à 25 bar pression relative |
| 432 | 0 à 30 bar pression relative |
| 462 | 0 à 40 bar pression relative |
| 463 | 0 à 60 bar pression relative |
| 464 | 0 à 100 bar pression relative |
| 475 | -0,25 à 0 bar pression relative |
| 476 | -0,4 à 0 bar pression relative |
| 477 | -0,6 à 0 bar pression relative |
| 478 | -1 à 0 bar pression relative |

3 Identification de l'exécution de l'appareil

| | |
|---|---|
| 479 | -1 à +0,6 bar pression relative |
| 480 | -1 à +1,5 bar pression relative |
| 481 | -1 à +3 bar pression relative |
| 482 | -1 à +5 bar pression relative |
| 483 | -1 à +9 bar pression relative |
| 484 | -1 à +15 bar pression relative |
| 485 | -1 à +24 bar pression relative |
| 487 | 0 à 0,6 bar pression absolue |
| 488 | 0 à 1 bar pression absolue |
| 489 | 0 à 1,6 bar pression absolue |
| 490 | 0 à 2,5 bar pression absolue |
| 491 | 0 à 4 bar pression absolue |
| 492 | 0 à 6 bar pression absolue |
| 493 | 0 à 10 bar pression absolue |
| 494 | 0 à 16 bar pression absolue |
| 495 | 0 à 25 bar pression absolue |
| 998 | Etendue de mesure spéciale, pression absolue |
| 999 | Etendue de mesure spéciale, pression relative |
| (3) Sortie | |
| 405 | 4 à 20 mA, 2 fils |
| (4) Raccordement au process | |
| 502 | G 1/4 DIN EN 837 |
| 503 | G 3/8 DIN EN 837 |
| 504 | G 1/2 DIN EN 837 (Standard) |
| 511 | 1/4-18 NPT DIN EN 837 |
| 512 | 1/2-14 NPT DIN EN 837 |
| 521 | G 1/4 DIN 3852-11 |
| 523 | G 1/2 DIN 3852-11 |
| 563 | 7/16-20 UNF femelle avec actionneur de valve |
| 583 | M20 × 1,5 avec tenon |
| 999 | Suivant indications client |
| (5) Matériau du raccord de process | |
| 20 | CrNi (acier inoxydable) |
| (6) Raccordement électrique | |
| 11 | Câble de raccordement |
| 24 | Torons mobiles |
| 36 | Connecteur enfichable M12 |
| 61 | Connecteur DIN EN 175301-803 Forme A ^a |
| 99 | Raccordement électrique spécial |
| (7) Options | |
| 085 | Homologation UKEX |
| 240 | Homologation EAC Ex |
| 462 | Signal de sortie inversé |
| 591 | Etranglement dans canal de pression |
| 624 | Exempt de trace d'huile et de graisse |
| 630 | Canal de pression agrandi |

3 Identification de l'exécution de l'appareil

| | |
|-----|-------------------------------|
| 880 | Homologation DNV ^b |
|-----|-------------------------------|

^a Uniquement certifié pour les applications gazières.

^b Disponible uniquement en combinaison avec un connecteur enfichable M12 et un connecteur.

| | | | | | | | |
|----------------------------|------------|-------|-------|-------|------|------|-------|
| Code de commande | (1) | (2) | (3) | (4) | (5) | (6) | (7) |
| Exemple de commande | 404710/000 | - 459 | - 405 | - 504 | - 20 | - 11 | / 000 |

3.3 Matériel livré

| |
|-------------------------------------|
| Appareil dans l'exécution commandée |
| Notice de mise en service |

3.4 Accessoires

Les accessoires ne sont pas testés suivant les requêtes de la DNV.

| Désignation | Description | Référence article |
|--|--|-------------------|
| Amplificateur séparateur d'entrée et alimentation à séparation galvanique Ex-i  | L'ampli-séparateur d'alimentation Ex "i" et l'ampli-séparateur d'entrée sont conçus pour utilisation de convertisseurs de pression à sécurité intrinsèque (Ex-i) et sources de courant mA en zone Ex. Les convertisseurs de mesure en technique 2 fils sont alimentés et les valeurs mesurées 0/4 à 20 mA sont transmises de la zone Ex vers la zone non Ex. La sortie du module peut être active ou passive. Vous trouverez les caractéristiques techniques ainsi que les prescriptions de sécurité correspondantes dans la notice de mise en service B 70753.0. | 00577948 |
| Connecteur, droit  | Le câble de raccordement en PVC a une longueur de 2 m et dispose d'un connecteur droit M12 × 1 à 4 pôles et contacts dorés du côté de l'appareil. | 00404585 |
| Connecteur, coudé  | Le câble de raccordement en PVC de 2 m de long dispose d'un connecteur M12 × 1 coudé à 4 pôles et contacts dorés du côté de l'appareil. | 00409334 |

4 Caractéristiques techniques

4.1 Généralités

| | |
|-----------------------------------|---|
| Normes de référence | suivant EN 60770-1 et IEC 61298-1 |
| Capteur | |
| Matériau | Capteur en silicium avec membrane en acier inoxydable |
| Agent de transmission de pression | Huile synthétique |
| Cycles d'effort admissibles | > 10 millions |
| Position de montage | Quelconque |
| Position de calibrage | Appareil à la verticale, raccord de process vers le bas |

4.2 Entrée

4.2.1 Etendue de mesure et précision

| Etendue de mesure bar | Linéarité ^a | Précision pour | | Stabilité à long terme ^b % MSP par an | Capacité de surcharge ^c bar | Pression d'éclatement bar |
|---------------------------------------|------------------------|-----------------------------|------------------------------------|--|--|---------------------------------|
| | % MSP ^f | 20 °C ^d % MSP | -20 à +85 °C ^e % MSP | | | |
| 0 à 0,6 bar pression relative/absolue | 0,3 | 0,5 | 1,2 | < 0,2 | 2,4 | 6 |
| 0 à 1 bar pression relative/absolue | 0,3 | 0,5 | 1,2 | | 4 | 10 |
| 0 à 1,6 bar pression relative/absolue | 0,3 | 0,4 | 1,0 | | 6,4 | 16 |
| 0 à 2,5 bar pression relative/absolue | 0,3 | 0,4 | 1,0 | | 10 | 25 |
| 0 à 4 bar pression relative/absolue | 0,3 | 0,4 | 1,0 | | 16 | 40 |
| 0 à 6 bar pression relative/absolue | 0,3 | 0,4 | 1,0 | | 24 | 60 |
| 0 à 10 bar pression relative/absolue | 0,3 | 0,4 | 1,0 | | 40 | 100 |
| 0 à 16 bar pression relative/absolue | 0,3 | 0,4 | 1,0 | | 64 | 160 |
| 0 à 25 bar pression relative/absolue | 0,3 | 0,4 | 1,0 | | 100 | 250 |
| 0 à 30 bar pression relative/absolue | 0,3 | 0,4 | 1,0 | | 100 | 250 |
| 0 à 0,25 bar pression relative | 0,3 | 0,5 | 1,2 | | 1 | 2,5 |
| 0 à 0,4 bar pression relative | 0,3 | 0,5 | 1,2 | | 1,6 | 4 |
| 0 à 40 bar pression relative | 0,3 | 0,4 | 1,0 | | 300 | 400 |
| 0 à 60 bar pression relative | 0,3 | 0,4 | 1,0 | | 300 | 400 |
| 0 à 100 bar pression relative | 0,3 | 0,4 | 1,0 | | 300 | 400 |
| -0,25 à 0 bar pression relative | 0,3 | 0,5 | 1,2 | | 1 | 2,5 |
| -0,4 à 0 bar pression relative | 0,3 | 0,5 | 1,2 | | 1,6 | 4 |
| -0,6 à 0 bar pression relative | 0,3 | 0,5 | 1,2 | | 2,4 | 6 |
| -1 à 0 bar pression relative | 0,3 | 0,5 | 1,2 | | 4 | 10 |
| -1 à +0,6 bar pression relative | 0,3 | 0,4 | 1,0 | | 6,4 | 16 |
| -1 à +1,5 bar pression relative | 0,3 | 0,4 | 1,0 | | 10 | 25 |
| -1 à +3 bar pression relative | 0,3 | 0,4 | 1,0 | | 16 | 40 |
| -1 à +5 bar pression relative | 0,3 | 0,4 | 1,0 | | 24 | 60 |
| -1 à +9 bar pression relative | 0,3 | 0,4 | 1,0 | | 40 | 100 |
| -1 à +15 bar pression relative | 0,3 | 0,4 | 1,0 | | 64 | 160 |
| -1 à +24 bar pression relative | 0,3 | 0,4 | 1,0 | | 100 | 250 |

^a Linéarité suivant réglage du point de coupure

^b Normes de référence EN 61298-1

4 Caractéristiques techniques

- ^c Tous les convertisseurs de pression tiennent au vide.
- ^d Comprend : linéarité, hystérésis, reproductibilité, écart entre la valeur de début d'étendue (offset) et de fin d'étendue de mesure
- ^e Comporte : linéarité, hystérésis, reproductibilité, écart des valeurs de début (offset) et de fin d'étendue de mesure, influence thermique sur le début de l'étendue de mesure (offset) et l'intervalle de mesure
- ^f MSP = l'intervalle de mesure

4.3 Sortie

| | |
|---|---|
| Signal de sortie Courant | 4 à 20 mA, 2 fils |
| Réponse à un échelon T ₉₀ | ≤ 2 ms |
| Charge 4 à 20 mA, 2 fils Influence de la charge | $R_B \leq (U_B - 16 \text{ V}) \div 0,022 \text{ A } (\Omega)$ ≤ 0,004 % par 100 Ω |

4.4 Caractéristiques mécaniques

| | |
|------------------------------------|-------------------------------------|
| Matériau | |
| Raccord de process | 316 Ti |
| Selon les spécifications du client | 316 L |
| Membrane | 316 L |
| Boîtier | 304 |
| Câble de raccordement | Silicone |
| Torons mobiles | Silicone |
| Connecteur coaxial M12 × 1 | PA, fonte d'alu zinc nickelé |
| Connecteur | |
| Sans homologation DNV | PA 66 GF, PA6-GF30, EPDM |
| Avec homologation DNV | PBT-GF30, PA, EPDM |
| Raccordement électrique | |
| Exécution spéciale | PUR |
| Poids | 170 g avec raccord de process G 1/2 |

4 Caractéristiques techniques

4.5 Influences de l'environnement

| | |
|--------------------------------------|---|
| Température ambiante | Equipment Protection Level Gb Classe de température T4 : -40 à +85 °C T5 : -40 à +70 °C T6 : -40 à +55 °C Equipment Protection Level Db Température de surface max. T100 °C : -40 à +85 °C T85 °C : -40 à +70 °C T70 °C : -40 à +55 °C |
| Température du milieu | -40 à +85 °C |
| Température de stockage | -40 à +100 °C |
| Indice de protection ^a | IP65 ,suivant EN 60529 |
| Compatibilité électromagnétique (CE) | suivant EN 61326-2-3:2022 |
| Emission de parasites | Classe B ^b |
| Résistance aux parasites | Normes industrielles |
| Contrainte mécanique | |
| Résistance aux chocs | 100 g/1 ms, suivant DIN EN 60068-2-27 |
| Résistance aux vibrations | 20 g à 15 jusqu'à 2000 Hz, suivant DIN EN 60068-2-6 |

^a L'indice de protection est uniquement atteinte avec une contre-pièce adaptée. Le diamètre du câble de raccordement est au minimum de 4,5 mm, au maximum de 7 mm.

^b Le produit est adapté pour les applications industrielles ainsi que pour les ménages et les petites entreprises.

Pour les conditions particulières d'utilisation, se référer au certificat d'examen de type.

4.6 Caractéristiques électriques



| | |
|--|---|
| Alimentation U _B ^a | |
| Tension nominale | DC 24 V |
| 4 à 20 mA | |
| Sans homologation DNV | DC 16 à 28 V |
| Avec homologation DNV | DC 21 à 24 V |
| Puissance absorbée | ≤ 23 mA |
| Circuit électrique | à sécurité intrinsèque |
| Raccordement électrique | |
| Eléments de raccordement | Câble fixe, torons mobiles, connecteur coaxial M12 ^b , connecteur ^b |

^a Ondulation résiduelle : les pointes de tension ne doivent pas être supérieures ou inférieures aux valeurs indiquées pour l'alimentation !

^b Avec homologation DNV.

4 Caractéristiques techniques

4.7 Homologations et marques de contrôle

| | | |
|---|-------------------|--|
|  | Désignation | ATEX |
| | Organisme d'essai | Eurofins Electrosuisse Product Testing AG |
| | Certificate n° | SEV 09 ATEX 0101 X |
| | Base d'essai | EN 60079-0, EN 60079-11 |
| | S'applique à | Type 404710 |
| | Désignation | UKEX |
| | Organisme d'essai | Bureau Veritas |
| | Certificate n° | EPS 22 UKEX 1 088 X |
| | Base d'essai | EN IEC 60079-0, EN 60079-11 |
| | S'applique à | Type 404710/.../085 |
|  | Désignation | DNV |
| | Organisme d'essai | DNV |
| | Certificate n° | TAA0000211 |
| | Base d'essai | DNV-CG-0339 |
| | S'applique à | Type 404710/...-36/062, Type 404710/...-61/062 |
| | Désignation | EAC Ex |
|  | Organisme d'essai | ПрофиТест / ProfiTest |
| | Certificate n° | RU C-DE.HB07.B.00659/22 |
| | Base d'essai | TP TC 012/2011 |
| | S'applique à | Type 404710 |

5 Montage



DANGER!

Le convertisseur de pression n'est pas conforme aux exigences „Equipement avec fonction de sécurité“ suivant la directive relative aux équipements sous pression 2014/68/UE.

- ▶ En présence de matières dangereuses, par ex. oxygène, acétylène, matières combustibles et toxiques, ainsi que des installations frigorifiques, réservoirs sous pression etc. les prescriptions s'y rapportant doivent être respectées !
Les prescriptions de sécurité et les instructions pour la prévention des accidents nationales et internationales doivent être respectées !
Le non respect de ces instructions peut causer des dégâts corporels et matériels !
L'exploitant de l'installation est responsable du respect des dispositions légales !
Seules les personnes qualifiées peuvent intervenir sur cet appareil.
-

5.1 Généralités

Avant le montage



DANGER!

Avant le montage du convertisseur de pression, l'installation doit être placée hors tension !



ATTENTION!

**Le convertisseur de pression ne peut être utilisé que dans des milieux pour lesquels la membrane est suffisamment résistante chimiquement (corrosion).
Une liaison électrique entre convertisseur de pression et raccord process (installation) doit être assurée.**



REMARQUE !

Le lieu de montage doit être facilement accessible, aussi près que possible du point de mesure ; il ne doit pas être soumis à des vibrations. Il faut respecter la température ambiante admissible (attention aux éventuels rayonnements thermiques).

Le convertisseur de pression peut être monté au-dessus ou en-dessous du point de prise de pression. La position nominale du convertisseur de pression est la position verticale. Suivant la configuration du point de mesure, il est possible de monter le convertisseur de pression dans une autre position.



REMARQUE !

Pour les conditions particulières d'utilisation, le certificat d'examen de type CE doit être respecté, ⇒ chapitre 8 "Certificats", Page 23.

5.2 Raccord de pression

Joint



DANGER!

Pour le mode de protection à sécurité intrinsèque, il faut utiliser une garniture plate pour le raccord de process s'y rapportant, par ex. suivant EN 837 !

- ▶ Après la mise en place du raccordement au process, il faut vérifier son étanchéité !
Si le convertisseur de pression est vissé dans un orifice taraudé, il faut utiliser **la longueur totale** du filetage du convertisseur de pression !
-



REMARQUE !

Si le convertisseur de pression est vissé dans un orifice taraudé, il faut utiliser la longueur totale du filetage du convertisseur de pression.

5 Montage

5.3 Dimensions

5.3.1 Raccordement électrique

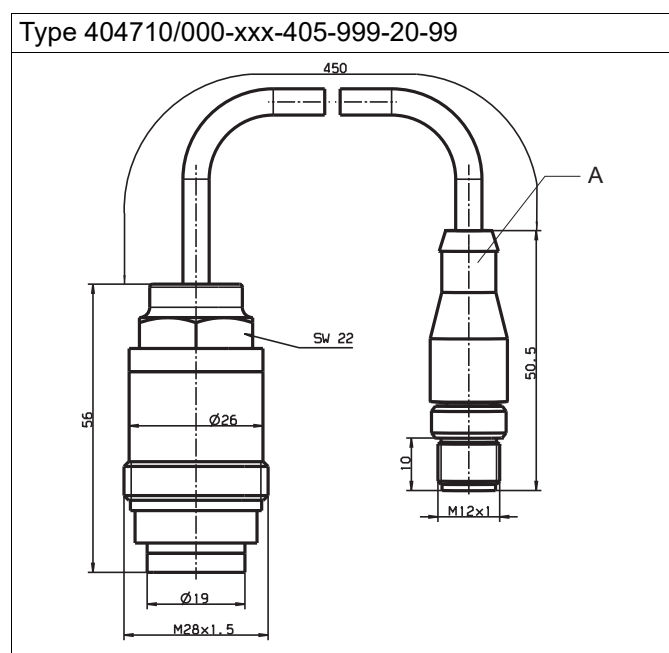
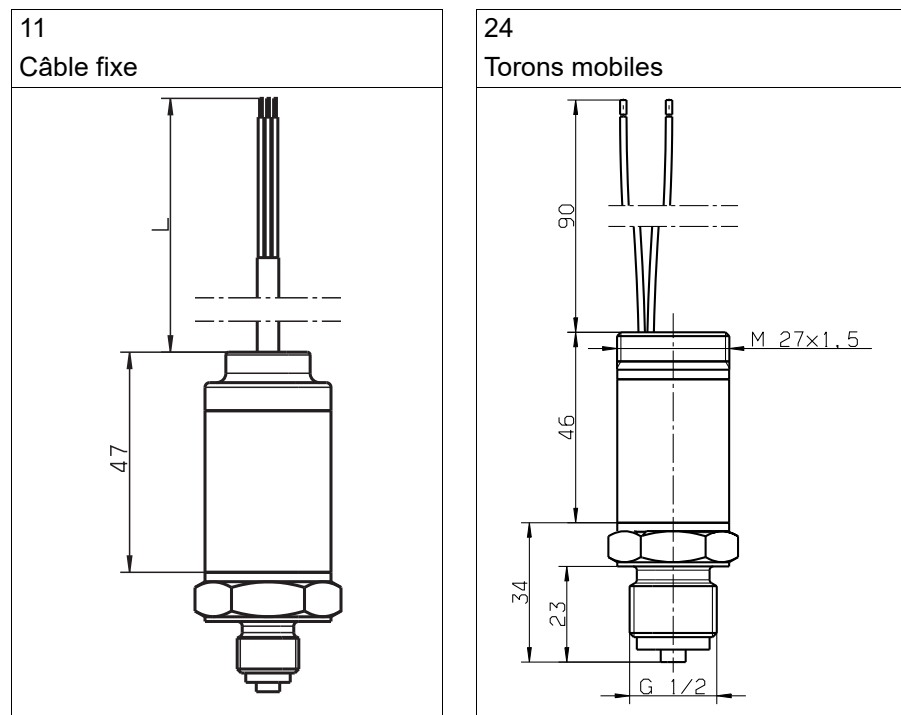

A Connecteur de câble 4 × 0,34, 4 pôle

Avec homologation DNV

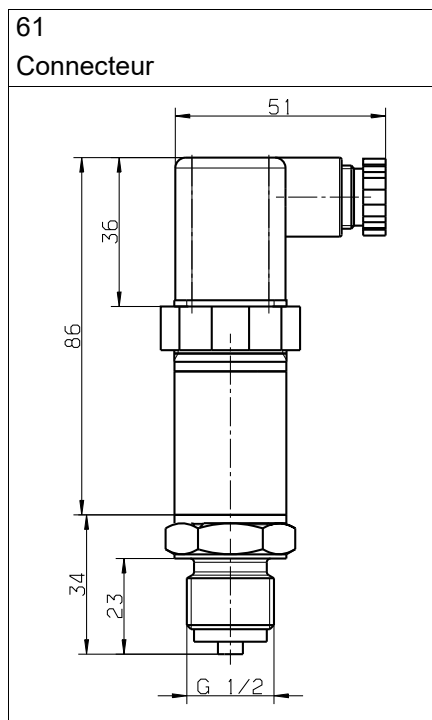
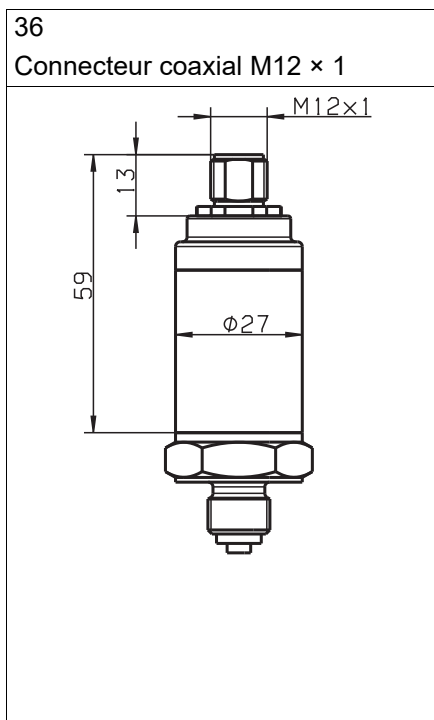

5 Montage

5.3.2 Raccords de process

Non affleurants

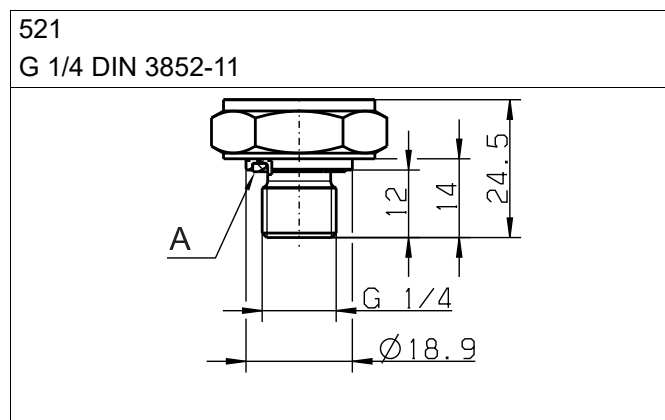
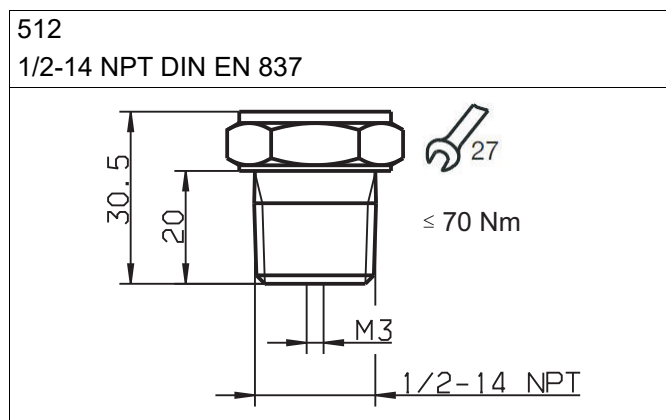
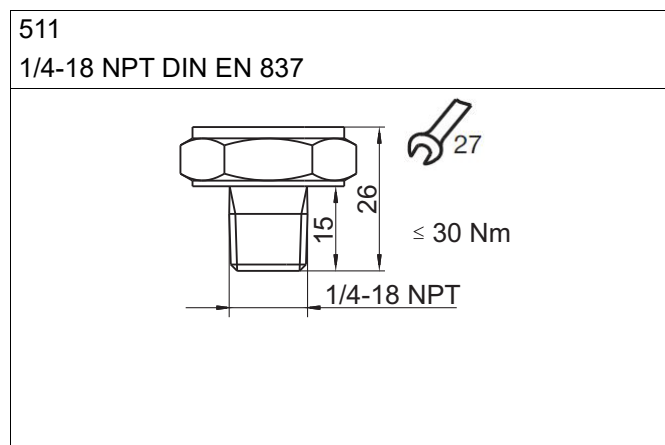
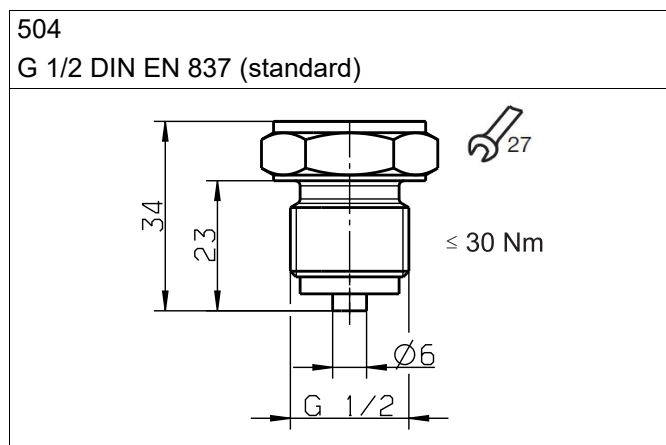
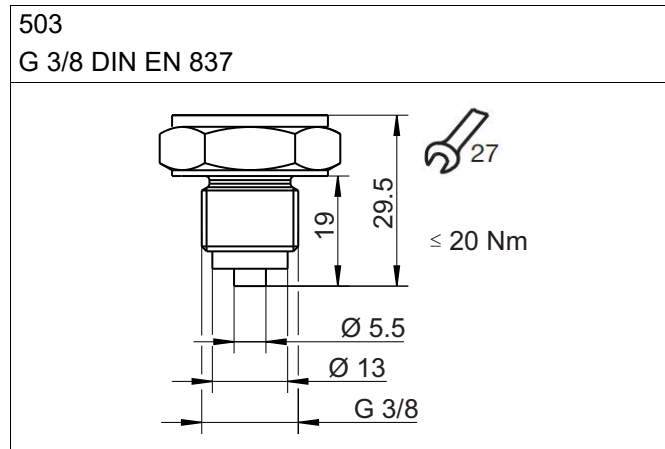
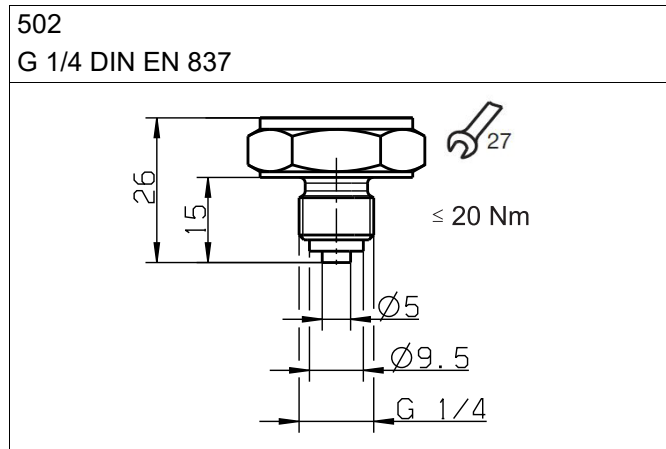

A Bague d'étanchéité profilée G 1/4

5 Montage

523
G 1/2 DIN 3852-11

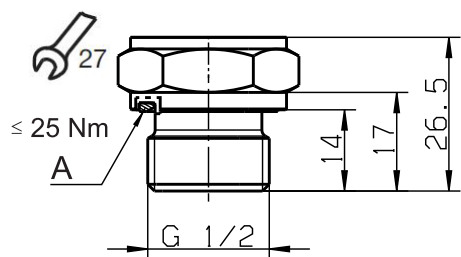

A Bague d'étanchéité profilée G 1/2

563
7/16-20 UNF femelle avec actionneur de valve

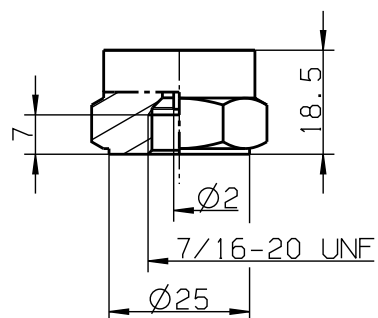

583
M20 × 1,5 avec tenon

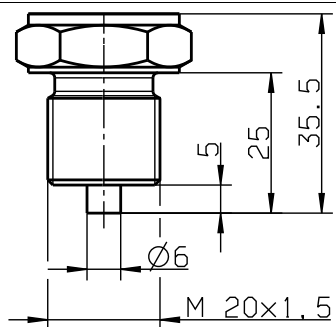

6 Installation

6.1 Raccordement électrique



DANGER!

Lors du raccordement électrique, les prescriptions s'y rapportant doivent être respectées :

- règlement pour équipements électriques en atmosphère explosive (Elex V)
- Prescription pour la construction d'installations électriques en atmosphères explosives
- Certificat d'examen de type CE

- ▶ Le raccordement électrique ne doit être effectué que par du personnel qualifié !
L'alimentation doit être à sécurité intrinsèque et ne doit pas dépasser les valeurs maximales suivantes :
U_i: DC 28 V
I_i: 100 mA
P_i: 750 mW
Inductance L interne effective : négligeable
Capacité C interne effective : ≤ 10,4 nF
Seuls les instruments de mesure à sécurité intrinsèque certifiés peuvent être utilisés dans des circuits à sécurité intrinsèque !

Pour le raccordement électrique 11 (câble fixe) les valeurs suivantes résultent en fonction de la longueur de câble L :

$$U_i \leq 28 \text{ V}$$

$$I_i \leq 100 \text{ mA}$$

$$P_i \leq 750 \text{ mW}$$

$$C_i \leq 10,4 \text{ nF} + 100 \frac{\text{pF}}{\text{m}} \times L$$

$$L_i \leq 1 \frac{\mu\text{H}}{\text{m}} \times L$$

Généralités

- Longueur du câble max. 50 m
- Rayon de courbure min. 120 mm (pour pose fixe)
- Empêcher la pénétration d'humidité dans l'extrémité du câble
- En cas de prolongation du câble, attention aux inductances et capacités qui dépendent de la longueur
- Les câbles de signal doivent cheminer séparément des câbles avec des tensions > 60 V
- Utiliser du câble blindé avec des conducteurs torsadés
- Éviter la proximité d'installations électriques puissantes



REMARQUE !



Le circuit électrique à sécurité intrinsèque doit être limité à la catégorie de surtension I, comme défini dans IEC 60664-1 et l'alimentation des circuits est réalisée exclusivement à partir d'une source d'alimentation de sécurité intrinsèque certifiée avec un niveau de protection „ib“.



REMARQUE !

Pour les conditions particulières d'utilisation, le certificat d'examen de type CE doit être respecté, ⇒ chapitre 8 "Certificats", Page 23.

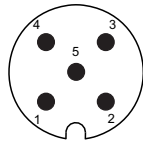
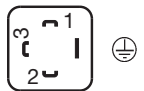
6.2 Schéma de raccordement

| Raccordement | | Brochage (Figure : raccordement au convertisseur de pression) | | | |
|---|---|---|---|---|------------------|
| | |  |  |  | |
| | | 11 Câble fixe | 24 Torons mo- biles | 36 Connecteur coaxial M12 x 1 | 61 Connecteur |
| 4 à 20 mA, 2 fils (sortie 405) | | | | | |
| Alimentation DC 16 à 28 V | $U_B/S+$ 0 V/S- | BU BK | BU BK | 1 BN 3 BU | 1 2 |
| Conducteur d'équipotentialité FB ^a |  | - | - | - | - |

^a Le convertisseur de pression doit être relié au système d'équipotentialité de l'installation via le raccord de process.

| Repérage des couleurs : câble de raccordement Connecteur coaxial M12 x 1 | 1 BN | Brun |
|---|------|-------|
| | 2 WH | Blanc |
| | 3 BU | Bleu |
| | 4 BK | Noir |

Le repérage des couleurs est **uniquement** valable pour le câble standard codé A !



ATTENTION!

Mettre le boîtier du convertisseur de pression à la terre via le raccord de process – pour la protection contre les champs électromagnétiques et les charges électromagnétiques – (mise à la terre pour des raisons fonctionnelles) !

6.3 Exemple de raccordement

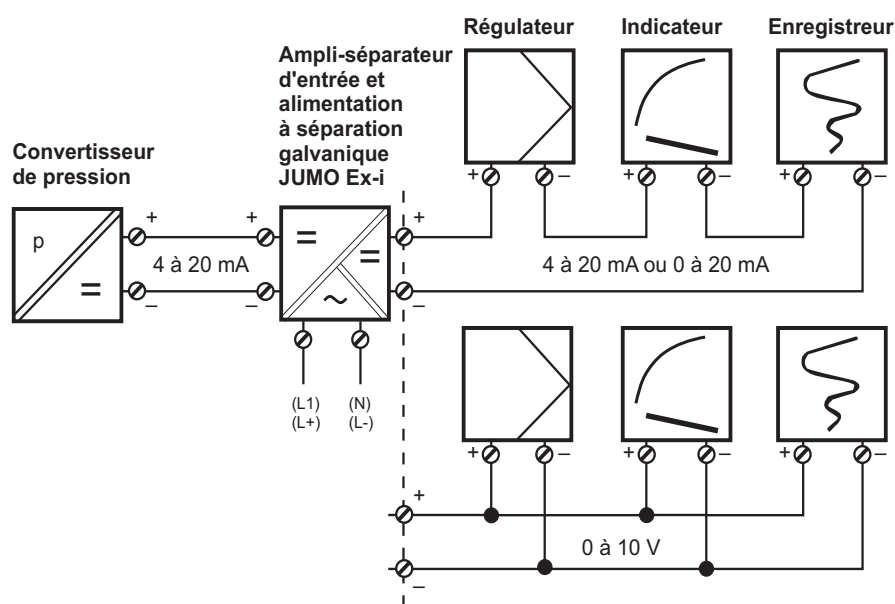

7 Entretien, nettoyage, retour, mise, rebut

7.1 Maintenance

Le convertisseur de pression ne nécessite aucun entretien.

7.2 Nettoyage



REMARQUE !

Évitez d'endommager l'appareil en raison d'un nettoyage inadéquat.

Ne pas endommager l'appareil, en particulier les parties en contact avec l'eau.
Le produit de nettoyage ne doit pas attaquer la surface et les joints.

7.3 Retour



AVERTISSEMENT!

Dommages corporels, dommages matériels, dommages environnementaux

Les résidus du milieu de mesure qui se trouvent sur l'appareil démonté peuvent provoquer des dommages corporels, nuire à l'environnement et endommager le matériel.

► Prendre des précautions suffisantes.



REMARQUE !

Toutes les informations nécessaires pour les retours se trouvent dans la [Supplementary sheet for product returns](#).



REMARQUE !

Le produit ne peut être démonté que par du personnel qualifié dans un environnement sûr, sans pression et sans tension de l'installation.

7.4 Traitement des déchets



- Cet appareil, ou les pièces remplacées, ne doit pas être jeté à la poubelle après utilisation.
- Effacer les programmes et les données enregistrés sur l'appareil.
- Retirer les piles, s'il y en a, sans endommager l'appareil dans la mesure du possible.
- Jeter l'appareil ainsi que les matériaux d'emballage conformément aux règlements et de façon non polluante.
- Respecter les lois et prescriptions de votre pays en matière d'évacuation et de traitement des déchets.

Conformément à la directive 2012/19/UE relative aux déchets d'équipements électriques et électroniques, les fabricants sont tenus d'offrir la possibilité de reprendre les appareils usagés. Demander la reprise au fabricant.

JUMO GmbH & Co. KGMoritz-Juchheim-Straße 1
36039 Fulda, GermanyTel.: +49 661 6003-0
Fax: +49 661 6003-500E-Mail: mail@jumo.net
Internet: www.jumo.netMore than **sensors + automation**

EU-Konformitätserklärung

EU declaration of conformity / Déclaration UE de conformité

Dokument-Nr.

CE 695

*Document No. / Document n°.***Hersteller**

JUMO GmbH & Co. KG

*Manufacturer / Etabli par***Anschrift**

Moritz-Juchheim-Straße 1, 36039 Fulda, Germany

*Address / Adresse***Produkt***Product / Produit***Name***Name / Nom***Typ***Type / Type***Typenblatt-Nr.***Data sheet no. / N°**Document**d'identification*

JUMO MIDAS S21 Ex

404710

404710

Produktbeschreibung*Product description / Description du produit*

Industrial pressure transmitter.

Wir erklären in alleiniger Verantwortung, dass das bezeichnete Produkt die Anforderungen der Europäischen Richtlinien erfüllt.

We hereby declare in sole responsibility that the designated product fulfills the requirements of the European Directives.

Nous déclarons sous notre seule responsabilité que le produit remplit les Directives Européennes.

Dokument-Nr.

Document No. / Document n°.

CE 695

EU-Konformitätserklärung

Seite: 1 von 5

8 Certificats

JUMO GmbH & Co. KG

Moritz-Juchheim-Straße 1
36039 Fulda, Germany

Tel.: +49 661 6003-0
Fax: +49 661 6003-500

E-Mail: mail@jumo.net
Internet: www.jumo.net



More than **sensors + automation**

1. Richtlinie

Directive / Directive

Name EMC 2014/30/EU

Name / Nom

Konformitätsbewertungsverfahren Mod. A

Conformity assessment procedure /

Procédure d'évaluation de la conformité

Datum der Erstanbringung des CE-Zeichens auf dem Produkt 2009

Date of first application of the CE mark to the product /

Date de 1ère application du sigle sur le produit

Angewendete Normen/Spezifikationen

Standards/Specifications applied / Normes/Spécifications appliquées

Referenz

Reference / Référence

Ausgabe

Edition / Édition

Bemerkung

Comment / Remarque

EN 61326-1

2013

EN 61326-2-3

2013

Gültig für Typ

Valid for Type / Valable pour le type

404710/...

2. Richtlinie

Directive / Directive

Name ATEX 2014/34/EU

Name / Nom

Konformitätsbewertungsverfahren Mod. B+D

Conformity assessment procedure /

Procédure d'évaluation de la conformité

Datum der Erstanbringung des CE-Zeichens auf dem Produkt 2009

Date of first application of the CE mark to the product /

Date de 1ère application du sigle sur le produit

Dokument-Nr.

Document No. / Document n°.

CE 695

EU-Konformitätserklärung

Seite: 2 von 5

JUMO GmbH & Co. KG

Moritz-Juchheim-Straße 1
36039 Fulda, Germany

Tel.: +49 661 6003-0
Fax: +49 661 6003-500

E-Mail: mail@jumo.net
Internet: www.jumo.net



More than **sensors + automation**

Angewendete Normen/Spezifikationen

Standards/Specifications applied / Normes/Spécifications appliquées

| Referenz <i>Reference / Référence</i> | Ausgabe <i>Edition / Édition</i> | Bemerkung <i>Comment / Remarque</i> |
|--|-------------------------------------|--|
| EN 60079-0 | 2018 | |
| EN 60079-11 | 2012 | |

Gültig für Typ

Valid for Type / Valable pour le type

404710/000-* -405-* -20-...

2.1 EU-Baumusterprüfbescheinigung

EU type examination certificate / Certificat d'examen de type UE

Zertifikatsnummer SEV 09 ATEX 0101 X Ausgabe 1
Certificate number / Numéro de certificat

Notifizierte Stelle Eurofins Electric & Electronic Product Testing
Notified Body / Organisme notifié AG, Luppmenstrasse 3, 8320 Fehraltdorf,
Switzerland

Angewendete Normen/Spezifikationen

Standards/Specifications applied / Normes/Spécifications appliquées

| Referenz <i>Reference / Référence</i> | Ausgabe <i>Edition / Édition</i> | Bemerkung <i>Comment / Remarque</i> |
|--|-------------------------------------|--|
| EN 60079-0 | 2018 | |
| EN 60079-11 | 2012 | |

Qualitätssicherung bezogen auf den Produktionsprozess

Quality assurance of the production process / L'assurance de la qualité de la production

Zertifikatsnummer Available on request
Certificate number / Numéro de certificat

Notifizierte Stelle BUREAU VERITAS Consumer Products
Notified Body / Organisme notifié Services Germany GmbH, Wilhelm-Hennemann-
Straße 8, 19061 Schwerin, Germany

Kennnummer 2004
Identification no. / N° d'identification

Dokument-Nr.
Document No. / Document n°.

CE 695

EU-Konformitätserklärung

Seite: 3 von 5

8 Certificats

JUMO GmbH & Co. KG

Moritz-Juchheim-Straße 1
36039 Fulda, Germany

Tel.: +49 661 6003-0
Fax: +49 661 6003-500

E-Mail: mail@jumo.net
Internet: www.jumo.net



More than sensors + automation

3. Richtlinie

Directive / Directive

Name

RoHS 2011/65/EU

Name / Nom

Konformitätsbewertungsverfahren

Mod. A

Conformity assessment procedure /

Procédure d'évaluation de la conformité

Datum der Erstanbringung des CE-Zeichens auf dem Produkt

2017

Date of first application of the CE mark to the product /

Date de 1ère application du sigle sur le produit

Angewendete Normen/Spezifikationen

Standards/Specifications applied / Normes/Spécifications appliquées

Referenz

Reference / Référence

Ausgabe

Edition / Édition

Bemerkung

Comment / Remarque

VDK Umweltrelevante Aspekte V1

bei der Produktentwicklung und
-gestaltung

Gültig für Typ

Valid for Type / Valable pour le type

404710/...

Dokument-Nr.

Document No. / Document n°.

CE 695

EU-Konformitätserklärung

Seite: 4 von 5

JUMO GmbH & Co. KG

Moritz-Juchheim-Straße 1
36039 Fulda, Germany

Tel.: +49 661 6003-0
Fax: +49 661 6003-500

E-Mail: mail@jumo.net
Internet: www.jumo.net



More than **sensors + automation**

Aussteller

Issued by / Etabli par

JUMO GmbH & Co. KG

Ort, Datum

Place, date / Lieu, date

Fulda, 2023-05-10

Rechtsverbindliche Unterschriften

Legally binding signatures /

Signatures juridiquement valable

Bereichsleitung Globaler Vertrieb

i. V. Markus Belmer

Qualitätsbeauftragter und Leiter Qualitätswesen

i. V. Harald Gienger



(1) **Attestation d'Examen UE de Type**

- (2) Appareils et systèmes de protection destinés à être utilisés en atmosphères explosibles - **Directive 2014/34/UE**
- (3) Numéro de l'attestation d'examen: **SEV 09 ATEX 0101 X**
- (4) Produit: Convertisseur de mesure de pression
Type JUMO MIDAS S21 Ex 404710 / 000 - *** - 405 - *** - 20 - **
- (5) Fabricant: JUMO GmbH & Co. KG
- (6) Adresse: Moritz-Juchheim-Strasse 1, 36039 Fulda, Germany
- (7) Le type de ce produit ainsi que toute autre variante acceptable de celui-ci sont spécifiés dans l'annexe de cette attestation d'examen.
- (8) Eurofins, comme organisme notifié n° 1258, conformément à l'article 17 de la Directive 2014/34/UE du Parlement des Communautés européennes et du Conseil du 26 février 2014, certifie que les Exigences Essentielles de Santé et de Sécurité relatives à la conception et à la construction de produits destinés à être utilisés en atmosphères explosibles, telles qu'énoncées à l'Annexe II de la directive, sont remplies.
Les résultats de l'examen sont consignés dans le rapport d'essai confidentiel. 19CH-01050.X02
- (9) Les Exigences Essentielles de Santé et de Sécurité sont remplies par la conformité à:
EN IEC 60079-0:2018
EN 60079-11:2012
- Les conditions spécifiées au point 18 constituent une exception.
- (10) Lorsque le numéro de l'attestation est suivi du signe « X », celui-ci renvoie aux conditions spéciales de sécurité d'utilisation du produit, telles que spécifiées dans l'annexe de cette attestation. Le signe « U » figurant après le numéro d'attestation indique qu'il ne faut pas considérer la présente attestation comme une attestation destinée à un appareil ou système de protection. Cette certification partielle peut servir de base à la certification d'un appareil ou d'un système de protection.
- (11) La présente attestation d'examen UE de type porte exclusivement sur la conception et la construction du produit spécifié. D'autres exigences de cette directive s'appliquent à la fabrication et à la mise sur le marché du produit, celles-ci ne font cependant pas l'objet de cette attestation.
- (12) Le produit portera un marquage incluant les éléments suivants:



Eurofins Electric & Electronic Product Testing AG
Notified Body ATEX

Martin Plüss
Certification de produit

www.eurofins.ch

Fehraltorf, 2021-04-20

Édition: 1

Page 1 of 4

T8a_V01



(13)

Annexe

(14)

Attestation d'Examen UE de Type no. SEV 09 ATEX 0101 X(15) **Description du produit**

Le convertisseur de mesure de pression JUMO MIDAS S21 Ex Type 404710 / 000 - *** - 405 - *** - 20- ** a pour fonction de convertir une grandeur de mesure physique (pression) en un signal uniforme électrique (courant de 4... 20 mA). Il est conçu pour être utilisé dans un environnement explosible. Le circuit électrique à protection propre est relié au moyen d'un câble fixe (longueur du câble en texte clair), connecteur rond M12 x 1 en exécution plastique ou au moyen d'un raccordement électrique spécial.

Designation de type

Convertisseur de mesure de pression JUMO MIDAS S21 Ex

Type 404710 / 000 - *** - 405 - *** - 20 - **

Les symboles " * " dans la désignation de type sont remplacés par les codes correspondant aux variantes, sans incidence sur la protection antideflagrante et sur la sécurité générale.

Circuit de mesure et d'alimentation en mode de protection à sécurité intrinsèque

Ex ib IIC

Ex ib IIIC

uniquement pour raccordement à un circuit électrique à protection propre certifiée.

Valeurs maximum pour connecteur rond et raccordement électrique spécial:

Ui s 28 V

Ii s 100 mA

Pis 0.75 W

Ci = 10.4 nF (Capacité interne effective)

Li "" 0 mH (Inductivité interne effective)

Valeurs maximum pour raccordement au moyen d'un câble spécial:

Ui s 28 V

Ii s 100 mA

Pis 0.75 W

Ci s 10.4 nF + 100 pF/m · encablure

Li s 1 µH/m · encablure

Classification de l'installation et utilisation:

stationary

Indice de protection:

IP65

Plage de température ambiante nominale:

Type de protection Gb

Température d'environnement:

T4: -40 °C to +85 °C

T5: -40 °C to +70 °C

T6: -40 °C to +55 °C

Equipment protection level Db

Température maximale des surfaces:

T100 °C: -40 °C to +85 °C

T85 °C: -40 °C to +70 °C

T70 °C: -40 °C to +55 °C



8 Certificats



Exemple de commande 404710/000 - 459 - 405 - 504 - 20 - 11 / 000
(1) (2) (3) (4) (5) (6) (7)

(1) Type de base

404710/000 JUMO MIDAS S21 Ex – Convertisseur de pression pour utilisation en zone Ex

(2)* Entrée Etendue de mesure nominale

432 0 à 30 bar pression relative
451 0 à 0.25 bar pression relative
452 0 à 0.4 bar pression relative
453 0 à 0.6 bar pression relative
454 0 à 1 bar pression relative
455 0 à 1.6 bar pression relative
456 0 à 2.5 bar pression relative
457 0 à 4 bar pression relative
458 0 à 6 bar pression relative
459 0 à 10 bar pression relative
460 0 à 16 bar pression relative
461 0 à 25 bar pression relative
462 0 à 40 bar pression relative
463 0 à 60 bar pression relative
464 0 à 100 bar pression relative
475 -0.25 à 0 bar pression relative
476 -0.4 à 0 bar pression relative
477 -0.6 à 0 bar pression relative
478 -1 à 0 bar pression relative
479 -1 à +0.6 bar pression relative
480 -1 à +1.5 bar pression relative
481 -1 à +3 bar pression relative
482 -1 à +5 bar pression relative
483 -1 à +9 bar pression relative
484 -1 à +15 bar pression relative
485 -1 à +24 bar pression relative
487 0 à 0.6 bar pression absolue
488 0 à 1 bar pression absolue
489 0 à 1.6 bar pression absolue
490 0 à 2.5 bar pression absolue
491 0 à 4 bar pression absolue
492 0 à 6 bar pression absolue
493 0 à 10 bar pression absolue
494 0 à 16 bar pression absolue
495 0 à 25 bar pression absolue
998 Etendue de mesure spéciale, pression absolue
999 Etendue de mesure spéciale, pression relative

(3) Sortie

405 4 à 20 mA, 2 fils

(4)* Raccordement au process

502 G 1/4 suivant DIN EN 837
504 G 1/2 suivant DIN EN 837
511 1/4-18 NPT suivant DIN EN 837
512 1/2-14 NPT suivant DIN EN 837
521 G 1/4 suivant DIN 3852-11
523 G 1/2 suivant DIN 3852-11
563 7/16-20 UNF femelle avec actionneur de valve
583 M20 x 1.5 avec tenon
999 suivant indications client

(5) Matériau du raccord de process

20 CrNi (acier inoxydable)

(6) Raccordement électrique

11 Câble fixe
24 Torons mobiles
36 Connecteur coaxial M12x1
61 Connecteur DIN EN 175301-803 Forme A
99 Raccordement électrique spécial

(7)* Code supplémentaire

000 Sans
462 Signal de sortie inversé
591 Etranglement dans canal de pression
624 Exempt de trace d'huile et de graisse
630 Canal de pression agrandi

*) Les références de commande numériques sont extensibles dans le sens de l'examen de base par des valeurs non mentionnées ici. Ces extensions n'ont pas d'influence sur la protection antidéflagrante et la sécurité générale.





(16) Conditions spéciales

- Les informations concernant les températures ambiantes admissibles ainsi que les classes de température, sont dans le mode d'emploi.
- Le capteur avec la douille du câble de connexion (NTS 61) ne peut être utilisé que pour les applications gaz.

(17) Exigences Essentielles de Santé et de Sécurité

Outre les Exigences Essentielles de Santé et de Sécurité remplies par les normes spécifiées au point 9, les conditions suivantes, prises en compte dans le rapport d'essai, sont également importantes:

| Paragraphe | Thème |
|------------|-------|
|------------|-------|

| | |
|--------|--|
| Aucune | |
|--------|--|

(18) Dessins et documents

Voir rapport d'essai « Documents du fabricant »



8 Certificats

JUMO GmbH & Co. KG

Moritz-Juchheim-Straße 1
36039 Fulda, Germany

Tel.: +49 661 6003-0
Fax: +49 661 6003-500

E-Mail: mail@jumo.net
Internet: www.jumo.net



More than sensors + automation

UK Declaration of Conformity

Document No. UK 201
Manufacturer JUMO GmbH & Co. KG
Address Moritz-Juchheim-Straße 1, 36039 Fulda, Germany

Product
Name JUMO MIDAS S21 Ex
Type 404710
Data sheet no. 404710

Product description
Pressure transmitter for use in Ex areas.

We hereby declare in sole responsibility that the designated product fulfills the requirements of the statutory instruments.

1. Statutory instrument

Name Electromagnetic Compatibility Regulations 2016
No. 1091
Conformity assessment procedure Mod. A
Date of first application of the UKCA mark to the product 2023

Standards/Specifications applied

| Reference | Edition | Comment |
|--------------|---------|---------|
| EN 61326-1 | 2013 | |
| EN 61326-2-3 | 2013 | |

Valid for Type
404710/...

Document No.

UK 201

UK Declaration of Conformity

Seite: 1 von 3

JUMO GmbH & Co. KG

Moritz-Juchheim-Straße 1
36039 Fulda, Germany

Tel.: +49 661 6003-0
Fax: +49 661 6003-500

E-Mail: mail@jumo.net
Internet: www.jumo.net



More than sensors + automation

2. Statutory instrument

Name The Restriction of the Use of Certain Hazardous Substances in Electrical and Electronic Equipment Regulations 2012 No. 3032

Conformity assessment procedure Mod. A

Date of first application of the UKCA mark to the product 2023

Standards/Specifications applied

| Reference | Edition | Comment |
|---|---------|---------|
| [VDK] Umweltrelevante Aspekte V1 bei der Produktentwicklung und -gestaltung | | |

Valid for Type

404710/...

3. Statutory instrument

Name The Equipment and Protective Systems Intended for Use in Potentially Explosive Atmospheres Regulations 2016 No. 1107

Conformity assessment procedure Mod. B+D

Date of first application of the UKCA mark to the product 2023

Standards/Specifications applied

| Reference | Edition | Comment |
|-------------|---------|---------|
| EN 60079-0 | 2018 | |
| EN 60079-11 | 2012 | |

Valid for Type

404710/...

Document No.

UK 201

UK Declaration of Conformity

Seite: 2 von 3

8 Certificats

JUMO GmbH & Co. KG

Moritz-Juchheim-Straße 1
36039 Fulda, Germany

Tel.: +49 661 6003-0
Fax: +49 661 6003-500

E-Mail: mail@jumo.net
Internet: www.jumo.net



More than **sensors + automation**

3.1 Type examination certificate

Certificate number

EPS 22 UKEX 1 088 X

Designated body

Bureau Veritas Consumer Products Services
United Kingdom Limited, 31 Kingsland Grange,
Woolston, Warrington, Cheshire, WA1 4RW

Quality assurance of the production process**Certificate number**

Available on request.

Designated body

Bureau Veritas Consumer Products Services
United Kingdom Limited, 31 Kingsland Grange,
Woolston, Warrington, Cheshire, WA1 4RW

Identification no.

8507

Issued by

JUMO GmbH & Co. KG

Place, date

Fulda, 2023-08-07

Legally binding signatures

Director of Global Sales
Markus Belmer

Head of Quality Department

Harald Gienger



- (1) **UK - Type Examination Certificate**
- (2) Equipment and protective systems intended for use in potentially explosive atmospheres – **UKSI 2016:1107 (as amended)**
- (3) UK - Type Examination Certificate Number
EPS 22 UKEX 1 088 X **Revision 0**
- (4) Equipment: Pressure transducer JUMO MIDAS S21 Ex 404710 / 000 - *** - 405 - *** - 20 - **
- (5) Manufacturer: JUMO GmbH & Co. KG
- (6) Address: Moritz-Juchheim-Straße 1
 36039 Fulda
 Germany
- (7) This equipment and any acceptable variation thereto are specified in the annex to this certificate and the documentation therein referred to.
- (8) Bureau Veritas Consumer Products Services United Kingdom Limited, approved body No. 8507 in accordance with UKSI 2016:1107 (as amended) Part 4, certifies that this equipment has been found to comply with the essential health and safety requirements relating to the design and construction of equipment and protective systems intended for use in potentially explosive atmospheres, given in Schedule 1 of UKSI 2016:1107 (as amended). The examination and test results are recorded in the confidential documentation under the reference number 22TH0288.
- (9) Compliance with the essential health and safety requirements has been assured by compliance with:
EN IEC 60079-0:2018 **EN 60079-11:2012**
- (10) If the sign "X" is placed after the certificate number, it indicates that the equipment is subject to special conditions for safe use specified in the annex to this certificate.
- (11) This UK - Type Examination Certificate relates only to the design and construction of the specified equipment in accordance with UKSI 2016:1107 (as amended). Further requirements apply to the manufacture of this equipment and its placing on the market. Those requirements are not covered by this certificate.
- (12) The marking of the equipment shall include the following:

II 2G Ex ib IIC T4...T6 Gb
 II 2D Ex ib IIIC T70°C...T100°C Db



Certification department of explosion protection

Warrington, 31-07-2023



Certificates without signature and seal are void. This certificate is allowed to be distributed only if not modified. Extracts or modifications must be authorized by Bureau Veritas Consumer Products Services United Kingdom Limited. EPS 22 UKEX 1 088 X, Revision 0.

Bureau Veritas Consumer Products Services United Kingdom Limited
<https://www.bureauveritas.co.uk/consumer-products-testing>
 +44 (0) 1925 854 360

Registered Office: 31 Kingsland Grange,
 Woolston, Warrington, Cheshire, WA1 4RW

Registered in England & Wales
 Company Number: 00852439

ZERT-0003-GBR-ZE-EX-V03 / TEMP-0005-GBR-ZE-EX-V01

1/4

8 Certificats



(13)

Annex

(14) **UK - Type Examination Certificate EPS 22 UKEX 1 088 X**

Revision 0

(15) Description of equipment:

The pressure transducer JUMO MIDAS S21 Ex type 404710 / 000 - *** - 405 - *** - 20 - ** serves for converting a physical measured quantity (pressure) into a standardized electrical signal (current signal 4 ... 20 mA). It is intended for use within potentially explosive areas.

The intrinsically safe circuit is connected with a non-detachable (cable length in plain text), circular connector M12x1 or a special electrical connection.

Measuring and supply circuit with the type of protection intrinsic safety

Ex ib IIC
Ex ib IIIC

Only for connection to a certified intrinsically safe circuit.

Rating:

Input and supply circuits:

With type of protection intrinsic safety Ex ib IIC

Only for connection to certified intrinsically safe circuit.

Maximum values for circular connector M12x1 and special electrical connection:

$U_i \leq 28 \text{ V}$
 $I_i \leq 100 \text{ mA}$
 $P_i \leq 750 \text{ mW}$
 $C_i \leq 10.4 \text{ nF}$ (effective internal capacitance)
 $L_i \approx 0 \text{ uH/m}$ (effective internal inductance)

Maximum values for electrical connection with non-detachable cable:

$U_i \leq 28 \text{ V}$
 $I_i \leq 100 \text{ mA}$
 $P_i \leq 750 \text{ mW}$
 $C_i \leq 10.4 \text{ nF} + 100 \text{ pF/m} \cdot \text{cable length}$
 $L_i \leq 1 \text{ uH/m} \cdot \text{cable length}$

Type designation:

Example of type designation 404710/000 - 459 - 405 - 504 - 20 - 11 / 000

(1) (2) (3) (4) (5) (6) (7)

(1) Basic type

404710/000 JUMO MIDAS S21 Ex – Pressure transducer for use in potentially explosive atmospheres

Certificates without signature and seal are void. This certificate is allowed to be distributed only if not modified. Extracts or modifications must be authorized by Bureau Veritas Consumer Products Services United Kingdom Limited. EPS 22 UKEX 1 088 X, Revision 0.

Bureau Veritas Consumer Products Services United Kingdom Limited
<https://www.bureauveritas.co.uk/consumer-products-testing>
+44 (0) 1925 854 360

Registered Office: 31 Kingsland Grange,
Woolston, Warrington, Cheshire, WA1 4RW

Registered in England & Wales
Company Number: 00852439

ZERT-0003-GBR-ZE-EX-V03 / TEMP-0005-GBR-ZE-EX-V01

2/4



UK - Type Examination Certificate EPS 22 UKEX 1 088 X

Revision 0

(2)* Pressure rated measuring range

- 432 0 to 30 bar relative pressure
- 451 0 to 0.25 bar relative pressure
- 452 0 to 0.4 bar relative pressure
- 453 0 to 0.6 bar relative pressure
- 454 0 to 1 bar relative pressure
- 455 0 to 1.6 bar relative pressure
- 456 0 to 2.5 bar relative pressure
- 457 0 to 4 bar relative pressure
- 458 0 to 6 bar relative pressure
- 459 0 to 10 bar relative pressure
- 460 0 to 16 bar relative pressure
- 461 0 to 25 bar relative pressure
- 462 0 to 40 bar relative pressure
- 463 0 to 60 bar relative pressure
- 464 0 to 100 bar relative pressure
- 475 -0.25 to 0 bar relative pressure
- 476 -0.4 to 0 bar relative pressure
- 477 -0.6 to 0 bar relative pressure
- 478 -1 to 0 bar relative pressure
- 479 -1 to +0.6 bar relative pressure
- 480 -1 to +1.5 bar relative pressure
- 481 -1 to +3 bar relative pressure
- 482 -1 to +5 bar relative pressure
- 483 -1 to +9 bar relative pressure
- 484 -1 to +15 bar relative pressure
- 485 -1 to +24 bar relative pressure
- 487 0 to 0.6 bar absolute pressure
- 488 0 to 1 bar absolute pressure
- 489 0 to 1.6 bar absolute pressure
- 490 0 to 2.5 bar absolute pressure
- 491 0 to 4 bar absolute pressure
- 492 0 to 6 bar absolute pressure
- 493 0 to 10 bar absolute pressure
- 494 0 to 16 bar absolute pressure
- 495 0 to 25 bar absolute pressure
- 998 special measuring range for absolute pressure
- 999 special measuring range for relative pressure

(3) Electrical output

- 405 4 to 20 mA, two-wire

(4)* Process connection

- 502 G 1/4 according to DIN EN 837
- 504 G 1/2 according to DIN EN 837
- 511 1/4-18 NPT according to DIN EN 837
- 512 1/2-14 NPT according to DIN EN 837
- 521 G 3/4 according to DIN 3852-11
- 523 G 1/2 according to DIN 3852-11
- 563 7/16-20 UNF inside with vent core pusher
- 583 M20 x 1.5 with stud
- 999 according to customer specification

(5) Material of process connection

- 20 CrNi (stainless steel)

Certificates without signature and seal are void. This certificate is allowed to be distributed only if not modified. Extracts or modifications must be authorized by Bureau Veritas Consumer Products Services United Kingdom Limited, EPS 22 UKEX 1 088 X, Revision 0.

Bureau Veritas Consumer Products Services United Kingdom Limited
<https://www.bureauveritas.co.uk/consumer-products-testing>
 +44 (0) 1925 854 360

Registered Office: 31 Kingsland Grange,
 Woolston, Warrington, Cheshire, WA1 4RW

Registered in England & Wales
 Company Number: 00852439

ZERT-0003-GBR-ZE-EX-V03 / TEMP-0005-GBR-ZE-EX-V01

3/4

8 Certificats



UK - Type Examination Certificate EPS 22 UKEX 1 088 X

Revision 0

(6) Electrical connection

- 11 attached cable
- 24 lose stranded wires
- 36 round plug M12×1
- 61 cable socket DIN EN 175301-803 form A
- 99 special electrical connection

(7)* Additional options

- 000 without
- 462 inverted output signal
- 591 choking coil in pressure channel
- 624 free from oil and grease
- 630 widened pressure channel

*) The numerical type keys can be extended with values not named here in the sense of the basic test. These extensions have no effect on the explosion protection and general safety.

(16) Reference number: 22TH0288

(17) Special conditions for safe use:

For details concerning the admissible ambient temperatures and temperature classes please refer to the user's manual.

The sensor with the connector cable socket (NTS 61) may only be used for gas applications.

(18) Essential health and safety requirements:

Met by compliance with standards.

Certification department of explosion protection

Warrington, 31-07-2023



Natalie Wilkinson

Certificates without signature and seal are void. This certificate is allowed to be distributed only if not modified. Extracts or modifications must be authorized by Bureau Veritas Consumer Products Services United Kingdom Limited, EPS 22 UKEX 1 088 X, Revision 0.

Bureau Veritas Consumer Products Services United Kingdom Limited
<https://www.bureauveritas.co.uk/consumer-products-testing>
+44 (0) 1925 854 360

Registered Office: 31 Kingsland Grange,
Woolston, Warrington, Cheshire, WA1 4RW

Registered in England & Wales
Company Number: 00852439

ZERT-0003-GBR-ZE-EX-V03 / TEMP-0005-GBR-ZE-EX-V01

4/4

|  产品组别 Product group: 404710 | | 产品中有害物质的名称及含量 China EEP Hazardous Substances Information | | | | | | |
|--|--|---|-----------|-----------|-----------------|---------------|-----------------|--|
| | | Component Name | | | | | | |
| 部件名称 Component Name | | 铅 (Pb) | 汞 (Hg) | 镉 (Cd) | 六价铬 (Cr(VI)) | 多溴联苯 (PBB) | 多溴二苯醚 (PBDE) | |
| 外壳 Housing (Gehäuse) | | ○ | ○ | ○ | ○ | ○ | ○ | |
| 过程连接 Process connection (Prozessanschluss) | | X | ○ | ○ | ○ | ○ | ○ | |
| 螺母 Nuts (Mutter) | | ○ | ○ | ○ | ○ | ○ | ○ | |
| 螺钉 Screw (Schraube) | | ○ | ○ | ○ | ○ | ○ | ○ | |

本表格依据SJ/T 11364的规定编制。
 This table is prepared in accordance with the provisions SJ/T 11364.
 ○：表示该有害物质在该部件所有均质材料中的含量均在GB/T 26572规定的限量要求以下。
 Indicate the hazardous substances in all homogeneous materials' for the part is below the limit of the GB/T 26572.
 x：表示该有害物质至少在该部件的某一均质材料中的含量超出GB/T 26572规定的限量要求。
 Indicate the hazardous substances in at least one homogeneous materials' of the part is exceeded the limit of the GB/T 26572.

8 Certificats



JUMO GmbH & Co. KG

Adresse :

Moritz-Juchheim-Straße 1
36039 Fulda, Allemagne

Adresse de livraison :

Mackenrodtstraße 14
36039 Fulda, Allemagne

Adresse postale :

36035 Fulda, Allemagne

Téléphone : +49 661 6003-0

Télécopieur : +49 661 6003-607

E-Mail: mail@jumo.net

Internet: www.jumo.net

JUMO-REGULATION SAS

7 rue des Drapiers

B.P. 45200

57075 Metz Cedex 3, France

Téléphone : +33 3 87 37 53 00

E-Mail: info.fr@jumo.net

Internet: www.jumo.fr

Service de soutien à la vente :

0892 700 733 (0,80 € TTC/minute)

JUMO Automation

S.P.R.L. / P.G.M.B.H. / B.V.B.A.

Industriestraße 18

4700 Eupen, Belgique

Téléphone : +32 87 59 53 00

Télécopieur : +32 87 74 02 03

E-Mail: info@jumo.be

Internet: www.jumo.be

JUMO Mess- und Regeltechnik AG

Laubisrütistrasse 70

8712 Stäfa, Suisse

Téléphone : +41 44 928 24 44

Télécopieur : +41 44 928 24 48

E-Mail: info@jumo.ch

Internet: www.jumo.ch



JUMO