

# JUMO dTRANS p20 DELTA Ex d

Differential pressure transmitter

With flameproof enclosure



Operating Manual



40302300T90Z001K000

V8.00/EN/00556414/2022-10-31



<b>1</b>	<b>Safety information</b>	<b>5</b>
1.1	Hazardous materials	5
<b>2</b>	<b>General information</b>	<b>7</b>
2.1	Areas of application	7
2.2	Scope of delivery	7
<b>3</b>	<b>Identifying the device version</b>	<b>11</b>
3.1	Nameplate	11
3.2	Order details	12
3.3	Accessories	13
3.4	Software	13
3.5	Dimensions	14
<b>4</b>	<b>Technical data</b>	<b>15</b>
4.1	General Information	15
4.2	Input	16
4.3	Output	16
4.4	Voltage supply	16
4.5	Mechanical features	17
4.6	Environmental influences	18
4.7	Accuracy	19
4.8	Approvals and approval marks	20
<b>5</b>	<b>Mounting</b>	<b>21</b>
5.1	Before mounting	21
5.2	Unscrew the front ring or case lid	21
5.3	Rotating the LCD (display)	22
5.4	Rotating the housing	23
5.5	Pressure connection	24
5.6	Bracket for wall and pipe mounting	25
5.7	Level measurement with a diaphragm seal	26
5.7.1	General information	26
5.7.2	Measuring arrangement in open or closed containers with $\pm$ measuring ranges	27
5.7.3	Measuring arrangement in open and closed containers with a measuring range of 0 to 1 bar	28
5.8	Level measurement without a diaphragm seal	29
5.8.1	Measuring arrangement in open or closed containers with $\pm$ and 0 to 1 bar measuring ranges	29
5.8.2	Measuring arrangement for steam layering and $\pm$ measuring ranges	31
5.8.3	Measuring arrangement for steam layering and a measuring range of 0 to 1 bar	32
5.9	Assembly in the explosion area	33

---

# Contents

---

<b>6</b>	<b>Installation</b> .....	<b>35</b>
6.1	Installation notes .....	35
6.1.1	Connection diagram "Ex" .....	37
6.2	Device with cable gland .....	38
<b>7</b>	<b>Operation</b> .....	<b>41</b>
7.1	Display .....	41
7.2	Operation with rotary knob or with setup programm .....	42
7.3	The level concept .....	43
7.3.1	The display level .....	44
7.3.2	The parameter level .....	45
<b>8</b>	<b>Configuration</b> .....	<b>49</b>
8.1	Data flow diagram .....	49
8.2	Description of the possible configurations .....	50
8.3	Level measurement configuration with a pressure specification - recommended (tank empty, tank full) .....	54
8.4	Level measurement configuration without a pressure specification .....	55
8.4.1	With a diaphragm seal in closed containers with a measuring range of 0 to 1 bar .....	55
8.4.2	With a diaphragm seal in closed containers with $\pm$ measuring ranges .....	57
8.4.3	Without a diaphragm seal in closed containers with $\pm$ measuring ranges or 0 to 1 bar .....	59
8.4.4	For steam layering with $\pm$ measuring ranges .....	61
8.4.5	For steam layering with a measuring range of 0 to 1 bar .....	64
<b>9</b>	<b>Maintenance</b> .....	<b>67</b>
9.1	Overcoming errors and malfunctions .....	67
<b>10</b>	<b>HART® 7 specification</b> .....	<b>69</b>
10.1	Device identification .....	69
10.2	Variable codes .....	69
10.3	HART® commands .....	70
10.4	Burst mode commands .....	73
10.5	Performance data .....	74
<b>11</b>	<b>Declaration of conformity</b> .....	<b>75</b>
<b>12</b>	<b>Examination certificate</b> .....	<b>79</b>
<b>13</b>	<b>China RoHS</b> .....	<b>83</b>

---

# 1 Safety information

---

## General

This manual contains information that must be observed in the interest of your own safety and to avoid material damage. This information is supported by symbols which are used in this manual as indicated.

Please read this manual before starting up the device. Store this manual in a place that is accessible to all users at all times.

If difficulties occur during startup, please do not intervene in any way that could jeopardize your warranty rights!

## Warning symbols



### DANGER!

This symbol indicates that **personal injury from electrocution** may occur if the appropriate precautionary measures are not taken.

---



### CAUTION!

This symbol in connection with the signal word indicates that **material damage or data loss** will occur if the respective precautionary measures are not taken.

---

## Note symbols



### NOTE!

This symbol refers to **important information** about the product, its handling, or additional benefits.

---

## 1.1 Hazardous materials

Using hazardous materials as a medium may result in abrasive and corrosive damage to components of the product that come into contact with the medium. The medium may leak and present a fire hazard and a risk to health.

Carry out a risk assessment taking into consideration the safety data sheet for the relevant hazardous substance for mounting, operation, maintenance, cleaning, and disposal:

- Comparison and systematic checking of the durability of the components of the product that come into contact with the medium and the admissible environmental influences.
- Assessment of the risk to people and the environment.
- Assessment of the fire hazard due to the product materials, the admissible environmental influences, and the voltage supply.

# 1 Safety information

---



### **DANGER!**

The device is suitable for measuring pressure in gases and liquids without solids content. In the SIL version (functional safety), this device is used in safety-related systems for minimum, maximum and area monitoring that fulfil the requirements of the series of standards IEC 61508:2010.

A failure of the device or other devices connected to it, e.g. due to an operating error, can lead to dangerous malfunctions of the whole plant.

- ▶ Therefore please also observe the corresponding safety manual from the device series.
- 



### **NOTE!**

Read this operating manual before putting the device into service. Keep the operating manual in a place that is accessible to all users at all times.

All necessary settings are described in this operating manual. Nevertheless, should problems be encountered during startup please do not make any unauthorized manipulations. This could endanger your rights under the warranty!

Please contact the nearest branch office or the head office.

---

## 2.1 Areas of application

### General information

The JUMO dTRANS p20 DELTA Ex d differential pressure transmitter combines maximum precision with simple operation. It is used to measure the differential pressure of gases, vapors, and liquids. The integrated LCD display shows measured values and device data.

The differential pressure transmitter with flameproof enclosure can be installed in zone 0.

The housing and sensors are manufactured from high-grade stainless steel. Diaphragm seals can also be connected for specific process technology applications (see data sheets 409772 to 409784).

The differential pressure transmitter is programmable and therefore readily adaptable to a variety of different measurement tasks. An easy-to-use setup program is available as an accessory to enable operation via the interfaces. A rotary knob makes manual operation on-site very convenient and quick.

The pressure transmitter with 4 to 20 mA and HART® protocol was evaluated with regard to functional safety and is certified by exida according to IEC 61508/-1/-2/-3. These measuring devices are suitable for monitoring process level and process pressure up to SIL2. Further details can be found in the Safety Manual.

### Use in hazardous „Ex“ areas

The pressure transmitter is approved for use in hazardous "Ex" areas. The device is explosion-proof and can be mounted in Zone 1.

### Functional safety use

In the SIL version, the device is permitted for use according to IEC 61508 if it has a corresponding identification marking on the nameplate.

## 2.2 Scope of delivery

### Operating Manual

The operating manual describe the mounting, the electrical connection, the startup and operation of the device.

## 2 General information

---

### Safety manual (option)

The safety manual describes the safe application with the installation according to IEC 61508.

### Calibration certificate

The device is supplied with a calibration certificate and a setup print-out.

These documents contain information about the set parameters and/or the measured parameters for the respective device.

If the calibration certificate is lost or if you need another copy, the calibration certificate can be requested from the manufacturer by specifying the device's F number (see nameplate). You will find the supplier's address on the back cover of the manual.

### Setup program (option)

The setup program is available as an option: part no. 00537577

All the device's parameters can be conveniently checked and adjusted using the setup program - there are also additional functions, e.g.:

- Recording the measured values
- Graphical view of temperature and pressure
- Detailed diagnostic messages
- Display of the complete order code and the device configuration (for follow-up orders)

The setup program accesses the device via

- the JUMO interface (standard) or
- the HART® interface (optional)



### **DANGER!**

**The JUMO interface must not be used in the Ex-area!**

**The device may only be operated using the rotary knob or the HART® interface!**

---

### PC interface cable (option)

Available as an accessory: PC interface cable with USB/TTL converter and two adapters (USB transmitter cable), part no. 00456352.

The device can be connected to a PC's USB port via the JUMO interface with the PC interface cable.

### HART® modem (option)

Available as an accessory: HART® modem for USB, part no. 00443447.

The device can be connected to a PC's USB® port via the HART® interface with the HART® modem.

### Input isolating amplifier (option)

Available as an accessory: Input isolating amplifier for Ex-applications, HART®-capable, part no. 00577948.

Devices with explosion protection ATEX Ex ia must be connected via an input isolating amplifier for use in the Ex-area!

### Diaphragm seal (option)

Available as an accessory: see data sheets 409770 to 409786.

Diaphragm seals are used for adjusting to particular applications if conventional pressure connections cannot be used.



## 2 General information

---



### CAUTION!

Diaphragm seals are installed by default and must not be removed from the device!

---

## 2 General information

---

## 3 Identifying the device version

### 3.1 Nameplate

#### Housing

Sample identification marking on the device housing

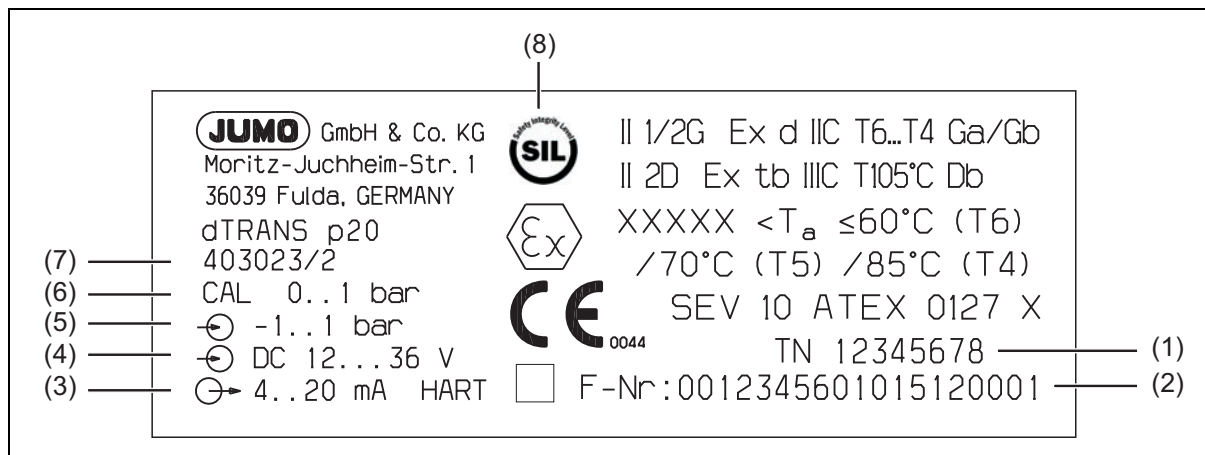

- |                             |                             |
|-----------------------------|-----------------------------|
| (1) Part number             | (2) Fabrication number      |
| (3) Output signal           | (4) Voltage supply          |
| (5) Nominal measuring range | (6) Default measuring range |
| (7) Type                    | (8) SIL version             |

#### Date of manufacture

The date of manufacture (year and calendar week) of the device is encoded in the manufacturing number. The numbers 12 to 15 identify the year of manufacture and the calendar week.

## 3 Identifying the device version

### 3.2 Order details

	<b>(1) Basic type</b>
403023	JUMO dTRANS p20 DELTA Ex d – differential pressure transmitter with flameproof enclosure
	<b>(2) Basic type extension</b>
0	None
2	SIL <sup>a</sup>
9	Special version
	<b>(3) Display</b>
0	None
1	With display
	<b>(4) Operation</b>
0	None
1	With control knob
	<b>(5) Input – nominal measuring range</b>
532	0 to 1 bar DP
530	-10 to +10 mbar DP <sup>b</sup>
531	-1 to +1 bar DP
533	-1 to +6 bar DP
534	-1 to +100 bar DP
	<b>(6) Output</b>
410	4 to 20 mA, two-wire with HART® protocol
	<b>(7) Process connection</b>
511	1/4-18 NPT according to DIN EN 837
998	Suitable for connection to membrane diaphragm seal
	<b>(8) Process connection material</b>
20	CrNi (stainless steel)
80	Tantalum
82	NiMo
	<b>(9) Measuring system, filling medium</b>
01	Silicon oil
02	Halogenized oil for oxygen application
	<b>(10) Extra codes</b>
000	None
100	Default customer-specific setting <sup>c</sup>
226	GOST/EAC approval <sup>d</sup>
624	Oil and grease free
633	Mounting brackets for 2" tube
634	TAG number
681	Expanded admissible ambient temperature <sup>e</sup>
694	Increased nominal pressure PN 420 bar

<sup>a</sup> Only available with output 410 and display 1. Not available with input 530 and extra code 681.

<sup>b</sup> Only available with process connection material 20.

<sup>c</sup> Please specify the setting you want in plain text. For default setting see "Accuracy" section in the data sheet.

<sup>d</sup> Available upon request.

<sup>e</sup> Not available with input 530, 531.

## 3 Identifying the device version

	(1)	(2)	(3)	(4)	(5)	(6)	(7)	(8)	(9)	(10)											
Order code	<input type="text"/>	/	<input type="text"/>	-	<input type="text"/>	-	<input type="text"/>	-	<input type="text"/>	-	<input type="text"/>	-	<input type="text"/>	-	<input type="text"/>	-	<input type="text"/>	-	<input type="text"/>	/	<input type="text"/>
Order example	403023	/	0	-	1	-	1	-	532	-	410	-	511	-	20	-	01	-	000	/	000

### 3.3 Accessories

Article	Part no.
PC interface with USB/TTL converter <sup>a</sup>	00456352
HART® modem USB <sup>b</sup>	00443447
Mounting kit, set includes 7/16-20UNF screws	00543777

Article	Data sheet
Manifolds	409706
Pressure separator with dairy pipe fitting DIN 11851	409772
Pressure separator with clamp connection	409774
Pressure separator with DRD flange or Varivent connection	409776
Pressure separator with ISS connection or SMS connection or RJT connection and slotted ring nut	409778
Diaphragm chemical seals 4MDV-10	409780
Pressure separator with male thread ISO 228/1 or ANSI B1.201	409782
Pressure separator with flange connection EN 1092-1 with sealing lip Form B1	409784
Pressure separator with flange connection to ANSI B 16.5 with sealing lip Form RF	409786
Ex-i Power supply/inut isolating amplifier	707530

<sup>a</sup> The PC interface cable is the connection between the JUMO interface of the differential pressure transmitter and the USB interface of a PC.

<sup>b</sup> The HART® modem is the connection between the HART® interface of the differential pressure transmitter and the USB interface of a PC.

### 3.4 Software

Description	Part no.
JUMO setup dTRANS p20 series	00537577
Device Type Manager (DTM), JUMO dTRANS p20	00738288

# 3 Identifying the device version

## 3.5 Dimensions

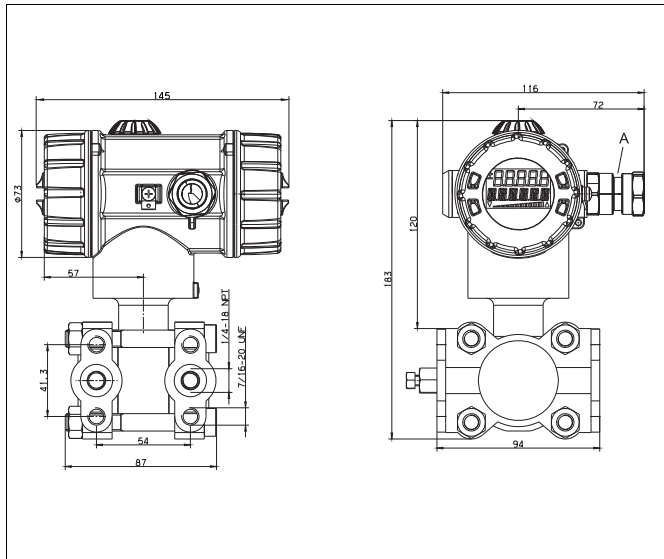

A M20 × 1.5 cable fitting

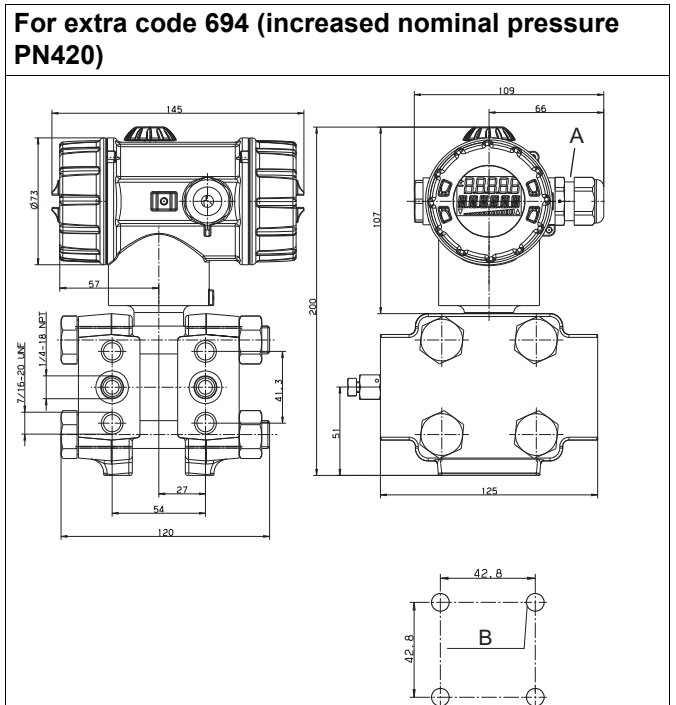

A M20 × 1.5 cable fitting  
B M8 for installation

**For nominal measuring range -10 to +10 mbar, nominal pressure PN2 (bar)**

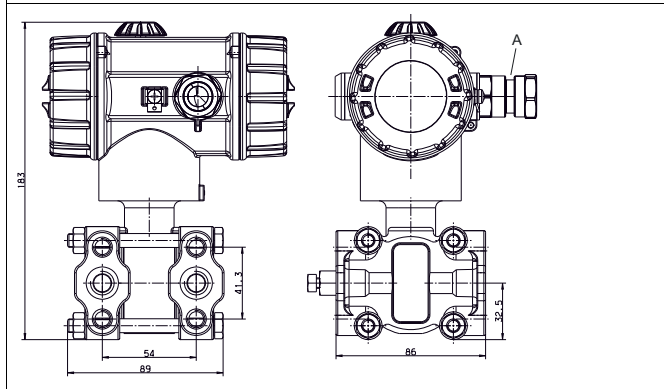

A M20 × 1.5 cable fitting

## 4.1 General Information

Reference conditions	DIN EN 60770 and DIN EN 61298
Ambient temperature	22 °C ±5 K
Air pressure	1000 hPa (±25 hPa)
Voltage supply	DC 24 V
Burden	50 Ω
Sensor system	Silicon sensor with stainless steel separating diaphragm
Pressure transfer medium	
For measuring system filling medium 1	Silicon oil
For measuring system filling medium 2	Halogenized filling oil
Admissible load changes	> 10 million
Position	
Mounting position	Any
Calibration position	Device upright, process connection at the bottom
Zero offset depending on position	≤ 1 mbar A zero offset is possible on-site or via setup
Display <sup>a</sup>	LCD, two-line with bar graph
Alignment	Display unit rotatable in 90° steps Housing rotatable ±160°
Size	Display 22 × 35 mm, font size 7 mm/5-digits
Color	Black
Portrayable measuring units	
Input pressure	inH <sub>2</sub> O, inHg, ftH <sub>2</sub> O, mmH <sub>2</sub> O, mmHg, psi, bar, mbar, kg/cm <sup>2</sup> , kPa, torr, MPa, mH <sub>2</sub> O
Measured value	% or scaled with freely adjustable measuring unit
Output current	mA
Sensor temperature	°C, °F
Additional display data	Minimum pressure, maximum pressure, error, overrange, underrange, operating hours
Operation	
On-site	With rotary knob and LCD
Setup program	Via interface
Interface	
Standard	JUMO interface <sup>b</sup>
For output 410 (4 to 20 mA with HART®)	JUMO interface <sup>b</sup> and HART® interface

<sup>a</sup> optional; SIL version only available with display

<sup>b</sup> The JUMO interface may not be used in a potentially explosive area! In such a case the device can be operated via the rotary knob or the HART® interface.



### NOTE!

For special conditions see chapter 4.6 "Environmental influences", Page 18.

## 4 Technical data

---

### 4.2 Input

Nominal pressure					
Nominal measuring range	-10 to +10 mbar DP <sup>a</sup>	-1 to +1 bar DP	0 to 1 bar DP	-1 to +6 bar DP	-1 to +100 bar DP
Nominal pressure (bar)	PN2	PN210	PN210, optionally PN420		

<sup>a</sup> Without SIL

### 4.3 Output

Analog output For output 410 (4 to 20 mA with HART®) Jump response time T60 Attenuation	4 to 20 mA, two-wire with HART® version 7  ≤ 190 ms without attenuation Adjustable 0 to 100 s
Burden For output 410 (4 to 20 mA with HART®)	Burden ≤ (U <sub>B</sub> -12 V) ÷ 0.022 A; additional: min. 250 Ω, max. 1100 Ω

### 4.4 Voltage supply

Voltage supply	DC 12 to 36 V
----------------	---------------



### 4.5 Mechanical features

Process connection Materials Membranes For process connection 20 (stainless steel) For process connection 82 (HASTELLOY®) For process connection 80 (tantalum) Flange Seal	Stainless steel 316 L  HASTELLOY® C276, material-no. 2.4819  Tantalum  Stainless steel 316 PTFE
Housing Housing material Cover material Control knob material For operation 0 (without control knob) For operation 1 (with control knob)	Precision casting 1.4408 Precision casting 1.4408, seal FPM  - PA
Explosion protection	EC-type examination certificate SEV 10 ATEX 127 X  II 1/2G Ex d IIC T6 ... T4 Ga/Gb II 2D Ex tb IIIC T105 °C Db
Weight For extra code 694 (increased nominal pressure)	Approximately 4.0 kg The weight of the device increases by approximately 3.8 kg.

## 4 Technical data

### 4.6 Environmental influences

Admissible temperatures Operation	Version	Temperature class	Maximum medium temperature	Ambient temperature <sup>a</sup>	Expanded ambient temperature (extra code 681) <sup>a, b, c</sup>
	II 1/2G Ex d	T6	70 °C	-40 to +60 °C	-50 to +60 °C
		T5	85 °C	-40 to +70 °C	-50 to +70 °C
		T4	110 °C	-40 to +85 °C	-50 to +85 °C
	II 2D Ex tb	T105 °C	100 °C	-40 to +85 °C	-50 to +85 °C
Storage	-40 to +85 °C				
Admissible humidity Operation Storage	100 % including condensation on the device outer case 90 % without condensation				
Admissible mechanical load Vibration strength Shock resistance	2 g, 10 to 500 Hz according to DIN EN 60770-3 15 g for 6 ms according to IEC 60068-2-29				
Electromagnetic compatibility Interference emission Interference immunity	According to EN 61326 Class B <sup>d</sup> Industry				
Protection type	IP66 according to DIN 60529				

<sup>a</sup> Under -20 °C limited function: stationary use, increased danger of cable break, display without function; under -30 °C operation of the device not possible.

<sup>b</sup> In the range from -40 to -50 °C the device must be permanently in operation. Furthermore, the lid with the device inspection glass must additionally be protected against mechanical impact and shock effects. Please contact JUMO for further details.

<sup>c</sup> Without SIL

<sup>d</sup> The product is suitable for industrial use as well as for households and small businesses.

## 4.7 Accuracy

Including non-linearity, hysteresis, non-repeatability, zero point and final value deviation (corresponds to measurement deviations according to IEC 61298-2), calibrated at vertical installation position with the process connection at the bottom

Differential pressure					
Nominal measuring range	-10 to +10 mbar DP <sup>a</sup>	-1 to +1 bar DP	0 to 1 bar DP	-1 to +6 bar DP	-1 to +100 bar DP
Default measuring range	0 to 10 mbar	0 to 1 bar		0 to 6 bar	0 to 100 bar
Smallest MSP <sup>b</sup>	1 mbar <sup>c</sup>	5 mbar <sup>c</sup>		0.350 bar	2.5 bar
Turndown ratio (r) <sup>d</sup>	r ≤ 20	r ≤ 400	r ≤ 200	r ≤ 20	r ≤ 40
Non-linearity for reference conditions	0.1 % for r ≤ 2	0.07 % for r ≤ 10		0.07 % for r ≤ 5	
	r × 0.05 % for 2 ≤ r ≤ 20	r × 0.007 % for 10 ≤ r ≤ 400	r × 0.007 % for 10 ≤ r ≤ 200	r × 0.014 % for 5 ≤ r ≤ 20	r × 0.014 % for 5 ≤ r ≤ 40
Accuracy in % of the set MSP at 20 °C	0.2 % for r ≤ 2	0.1 % for r ≤ 10		0.1 % for r ≤ 5	
	r × 0.1 % for 2 ≤ r ≤ 20	r × 0.01 % for 10 ≤ r ≤ 400	r × 0.01 % for 10 ≤ r ≤ 200	r × 0.02 % for 5 ≤ r ≤ 20	r × 0.02 % for 5 ≤ r ≤ 40
Accuracy in % of the set MSP Range: 20 to 85 °C	0.5 % for r ≤ 2 (only to 60 °C)	0.2 % for r ≤ 10		0.2 % for r ≤ 5	
	r × 0.25 % for 2 ≤ r ≤ 20 (only to 60 °C)	r × 0.02 % for 10 ≤ r ≤ 400	r × 0.02 % for 10 ≤ r ≤ 200	r × 0.04 % for 5 ≤ r ≤ 20	r × 0.04 % for 5 ≤ r ≤ 40
Accuracy in % of the set MSP Range: -40 to +20 °C	1.0 % for r ≤ 2	0.6 % for r ≤ 10		0.6 % for r ≤ 5	
	r × 0.5 % for 2 ≤ r ≤ 20	r × 0.06 % for 10 ≤ r ≤ 400	r × 0.06 % for 10 ≤ r ≤ 200	r × 0.12 % for 5 ≤ r ≤ 20	r × 0.12 % for 5 ≤ r ≤ 40
Accuracy in % of the set MSP Range: 60 to 85 °C	2.0 % for r ≤ 2	2.0 % for r ≤ 2		2.0 % for r ≤ 2	
	r × 1.0 % for 2 ≤ r ≤ 20				
Influence of the static pressure P (bar) in % of the nominal measuring range	≤ 1 %	≤ P × 0.0005 %	≤ P × 0.0003 %	≤ P × 0.0025 %	≤ P × 0.001 %
Long-term stability in % of the nominal measuring range	≤ 0.6 %/year	≤ 0.1 %/year			≤ 0.2 %/year

<sup>a</sup> Without SIL

<sup>b</sup> MSP = measuring span

<sup>c</sup> For the calibration certificate from JUMO the smallest MSP is 10 mbar. MSPs smaller than 10 mbar can be adjusted by the user.

<sup>d</sup> r = span of the nominal measuring range ÷ adjusted measuring span

## 4 Technical data

---

### 4.8 Approvals and approval marks

Approval mark	Test facility	Certificates/ certification numbers	Inspection basis	Valid for
ATEX	Electrosuisse	SEV 10 ATEX 0127 X, issue 03 (2017-10-12)	EN 60079-0 EN 60079-1 EN 60079-26 EN 60079-31	403023/...
EAC TR ZU	RU	RU C-DE.HB07.B.00086/20	TR ZU 012/2011 (Ex)	Extra code 226
SIL	exida	JUMO 2203088 C001	IEC 61508:2010-1/-2/-3	Basic type extension 2

## 5.1 Before mounting



### DANGER!

Depressurize the plant before installing the device!

The device may only be opened in the potentially explosive area when disconnected from the power supply!



### NOTE!

Select a freely accessible and low-vibration installation location, preferably near the measuring point. Ensure that the admissible ambient temperature is adhered to (take possible heat radiation into account).

The device can be installed above or below the pressure sensing point.

## 5.2 Unscrew the front ring or case lid

The bezel and the rear case lid can be removed once the locking screws (1) have been loosened. A size 1.5 hex wrench is required to loosen the locking screws.

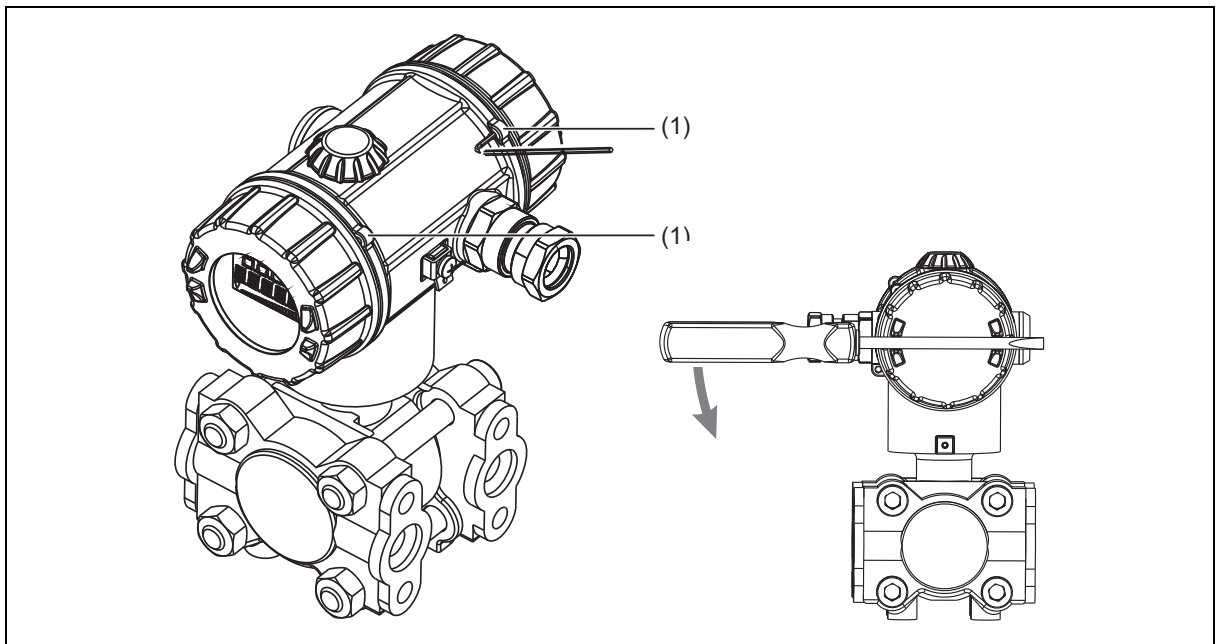

(1) Bezel



### NOTE!

Only tighten by hand!

# 5 Mounting

## 5.3 Rotating the LCD (display)

### Installation position

The rated position of the device is vertically upright.

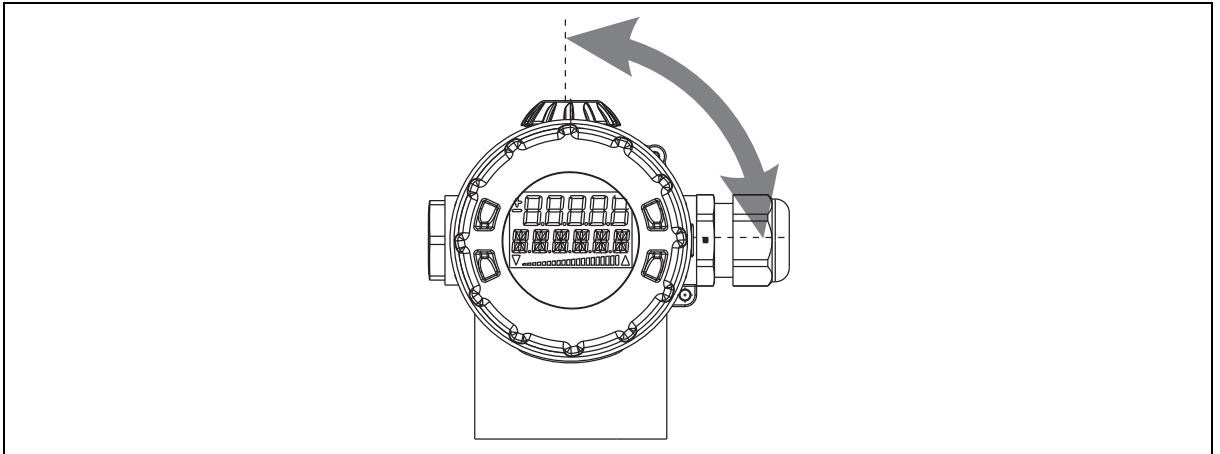

Depending on the conditions of the measuring point, the device can be installed in any other position. The LCD display can be rotated in 90° steps depending on the desired installation position.

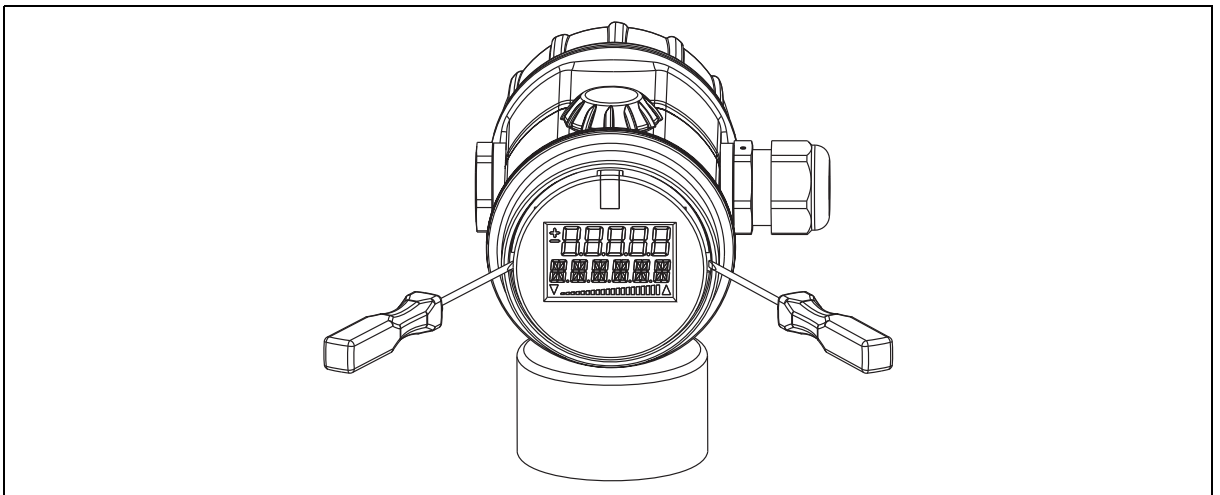

1. To unscrew the bezel, see chapter 5.2 "Unscrew the front ring or case lid", Page 21.
2. Lift out the electronics module using a narrow (small) screwdriver.
3. Rotate the electronics module into the desired position (90° steps) and insert again.
4. Screw on the bezel so that it is hand-tight.
5. Turn the locking screw until it is tight.

### 5.4 Rotating the housing

The housing can be rotated by  $\pm 160^\circ$ .

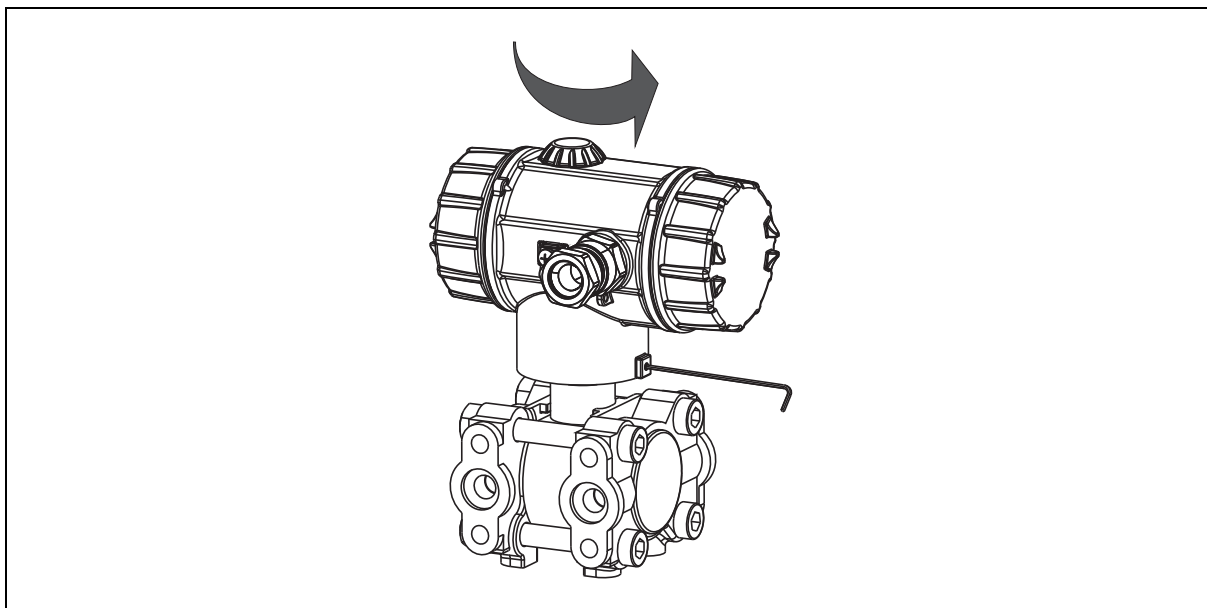

1. Loosen the threaded pin using a 1.5 mm hex wrench.
2. Rotate the housing to the desired position.
3. Screw on the threaded pin again until it is **tight**.

# 5 Mounting

---

## 5.5 Pressure connection

### Seals

Operating conditions (for example material compatibility) must be considered when selecting the seal.

### Checking for seal tightness

The pressure connection must be checked for seal tightness once established.



#### CAUTION!

If shut-off valves are used incorrectly, this can lead to personal injury or significant material damage!

Observe the correct order when opening or closing the valves!

- ▶ The device must not be vented when **used in toxic media!**
- 



#### NOTE!

Mount the device so that abrasion at the process connection is avoided.

---

### Differential pressure

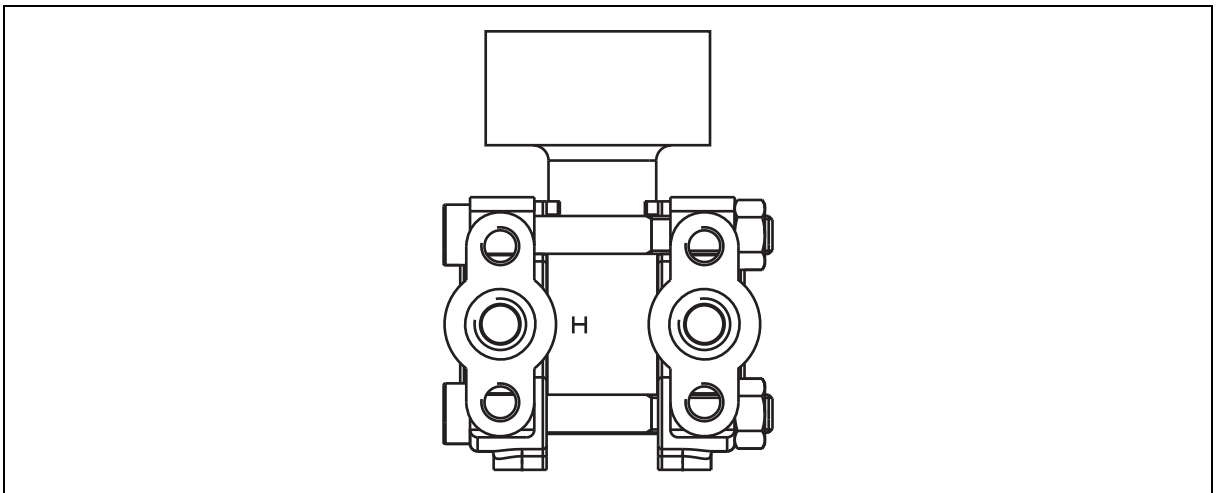

#### NOTE!

The connection for the higher pressure is labeled with "H".

---



### 5.6 Bracket for wall and pipe mounting

#### Mounting example

(Part no. 00543777)

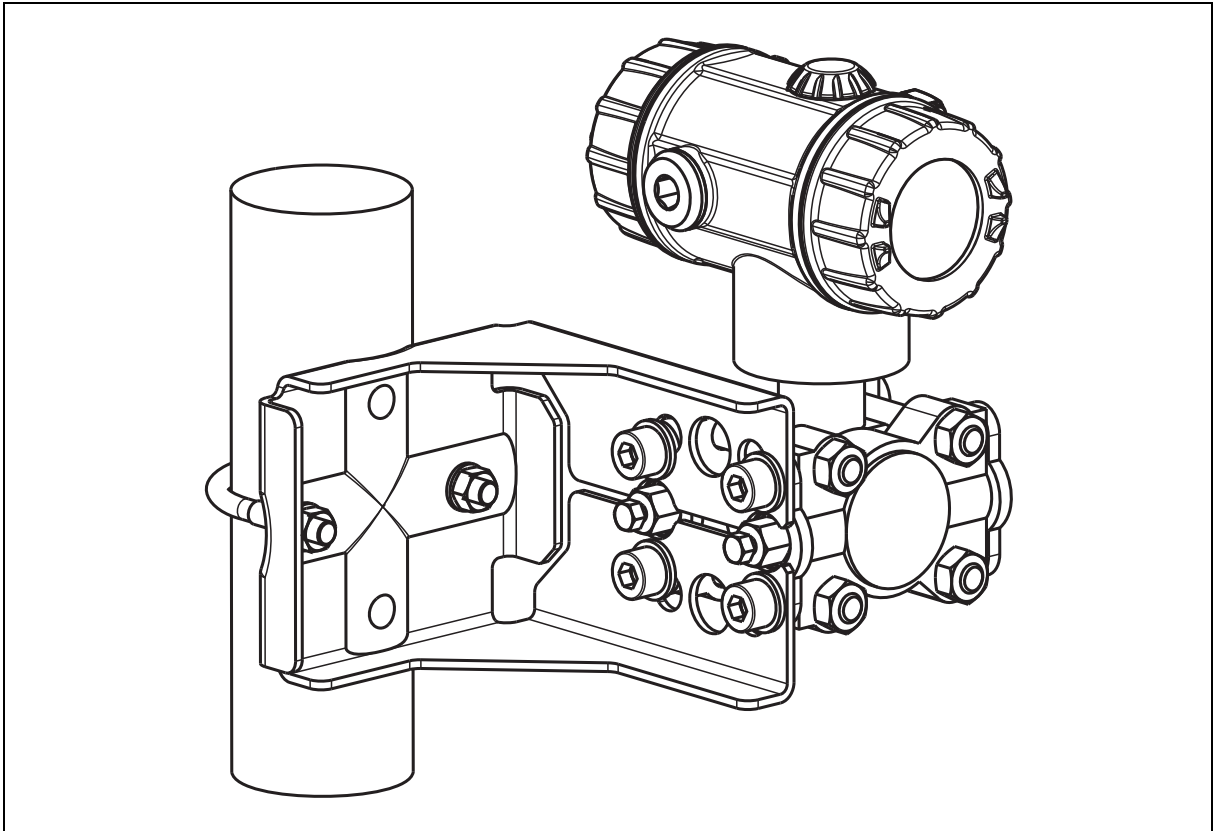

# 5 Mounting

---

## 5.7 Level measurement with a diaphragm seal

The device is ideally suited for level measurements in open and closed containers.

### 5.7.1 General information

A device with a capillary and diaphragm seals is a closed system that is filled with oil under vacuum.

- Remove membrane protection before installation
- Do not open closed system
- Do not touch or clean the diaphragm seal membranes with hard or sharp tools
- Bending radius of the capillaries:  $\geq 100$  mm
- Install capillaries such that they are free from vibration in order to avoid pressure fluctuations and device faults; avoid shaking during operation
- To ensure correct measuring results, do not install the capillaries in the vicinity of heating or cooling lines; capillaries should preferably have the same temperature on both sides during operation; isolate the capillary in case of large temperature differences
- The length of the capillaries and the diaphragm seal connections used (material, diameter) should be the same for the duplex diaphragm seal system



#### NOTE!

The filling oil influences the temperature application range and the response time of a diaphragm seal system. The medium and ambient temperature, as well as the process pressure are therefore decisive when selecting the filling oil.

Take note of the maximum possible temperature and pressures during commissioning/cleaning of the tank.

Pay attention to the tolerability of the filling oil with the requirements of the medium. For example, only filling oils that do not pose a health risk may be used in the food industry.

---



#### NOTE!

The level measurement is only ensured between the top edge of the lower diaphragm seal and the bottom edge of the upper one.

In vacuum applications it is recommended to install the device below the lower diaphragm seal. This prevents a vacuum load on the diaphragm seal caused by presence of the filling oil in the capillaries.

---

## 5.7.2 Measuring arrangement in open or closed containers with $\pm$ measuring ranges

The device must be installed according to the following diagram:

1. Always connect the minus side diaphragm seal via a capillary above the maximum filling level (MINUS input is at top).
2. Always connect the plus side diaphragm seal (marked "H") via a capillary at the bottom process connection (PLUS input is at bottom).
3. The level measurement is only ensured between the top edge of the lower diaphragm seal and the bottom edge of the upper one.
4. The device can be placed (in terms of height) anywhere between the lower and upper diaphragm seal.
5. In vacuum applications it is recommended to install the device below the lower diaphragm seal. This prevents a load on the diaphragm seal membrane caused by the filling oil in the capillaries.
6. For the device configuration, see chapter 8 "Configuration", Page 49.

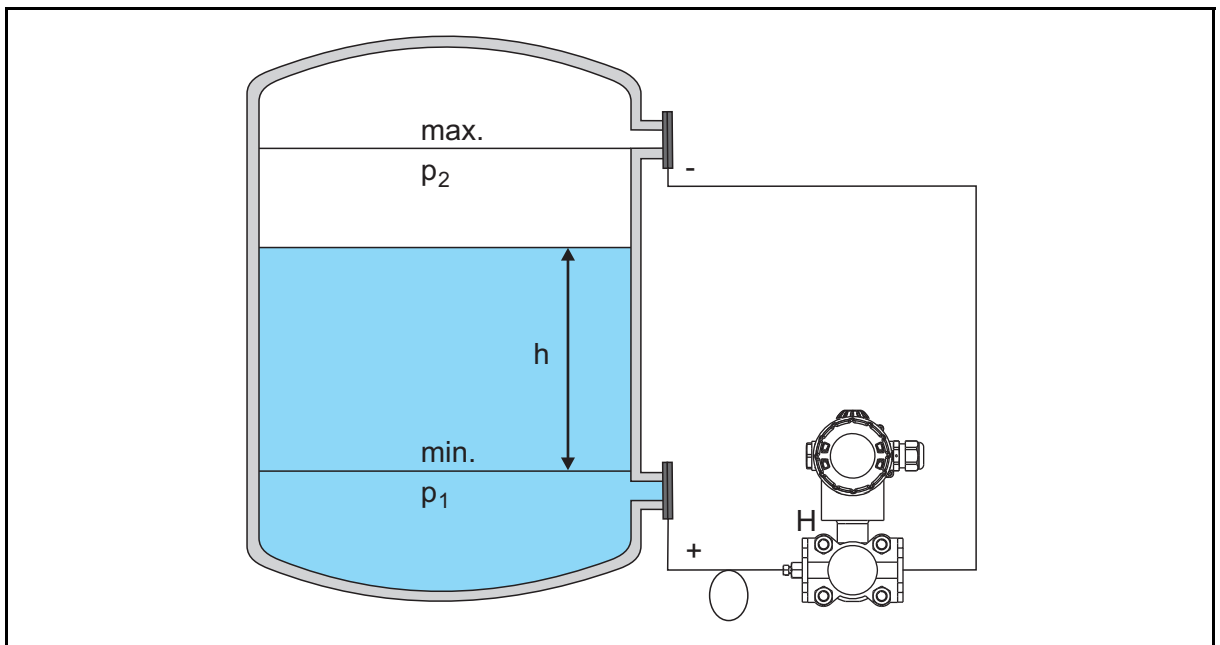

$h$  (filling level)      4 to 20 mA

# 5 Mounting

## 5.7.3 Measuring arrangement in open and closed containers with a measuring range of 0 to 1 bar

The device must be installed according to the following diagram:

1. Always connect the minus side diaphragm seal via a capillary at the bottom process connection (MINUS input is at bottom).
2. Always connect the plus side diaphragm seal (marked "H") via a capillary above the maximum filling level (PLUS input is at top).
3. The level measurement is only ensured between the top edge of the lower diaphragm seal and the bottom edge of the upper one.
4. The device can be placed (in terms of height) anywhere between the lower and upper diaphragm seal.
5. In vacuum applications it is recommended to install the device below the lower diaphragm seal. This prevents a load on the diaphragm seal membrane caused by the filling oil in the capillaries.
6. For the device configuration, see chapter 8 "Configuration", Page 49.

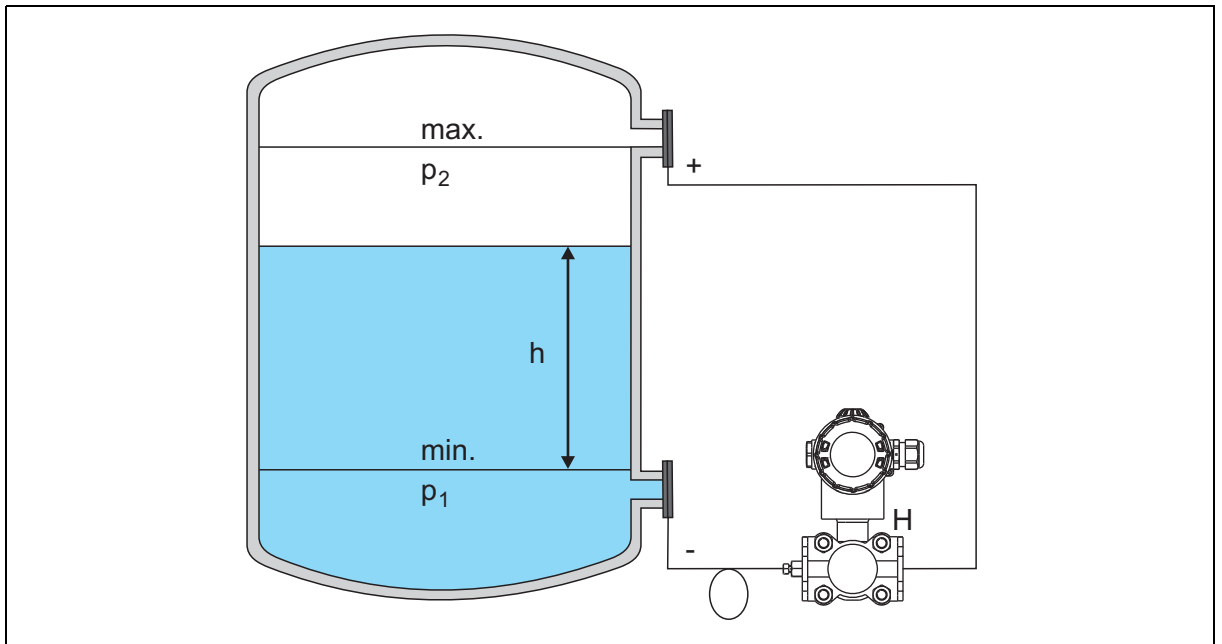

h (filling level)      4 to 20 mA



### NOTE!

There must be **no** zero point adjustment performed after the installation when the tank is empty.

## 5.8 Level measurement without a diaphragm seal

The device is ideally suited for level measurements in open and closed containers.

### 5.8.1 Measuring arrangement in open or closed containers with $\pm$ and 0 to 1 bar measuring ranges

The device must be installed according to the following diagram:

1. Always connect the minus side (zero) via a differential pressure pipe at the top process connection (MINUS input is at top).
2. Always connect the plus side (marked "H") via a differential pressure pipe below the maximum filling level (PLUS input is at bottom).
3. If possible, install the device below the lower measurement connection so that the lower differential pressure pipe is always filled with liquid.
4. It is a good idea to mount cutters and drain valves in order to catch and remove deposits, pollutants or liquid in the differential pressure pipes
5. For the device configuration, see chapter 8 "Configuration", Page 49.

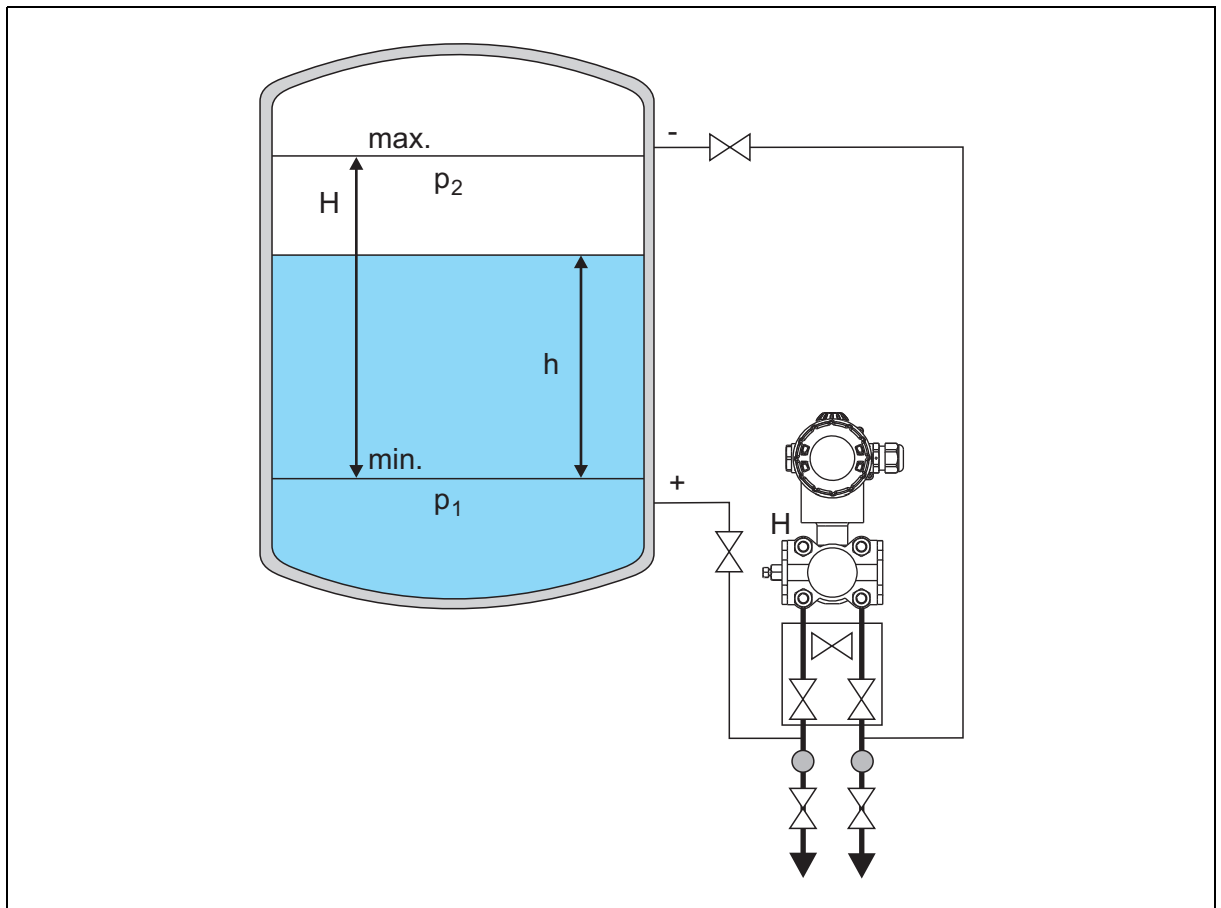

h (filling level)      4 to 20 mA



#### NOTE!

Applies for  $\pm$  measuring ranges or a measuring range from 0 to 1 bar.

It is recommended to install the device behind a shut-off valve in order to allow easy cleaning and functional testing.

## 5 Mounting

---

Do not install the device in the following positions:

- in the filling flow
- in the tank outlet
- at a position in the tank that could be affected by the mixer pressure pulses

With media that can harden upon cooling, the measuring device must be incorporated in the insulation.

## 5.8.2 Measuring arrangement for steam layering and $\pm$ measuring ranges

The device must be installed according to the following diagram:

1. Always connect the minus side (zero) via a differential pressure pipe at the top process connection (MINUS input is at top).
2. Always connect the plus side (marked "H") via a differential pressure pipe below the maximum filling level (PLUS input is at bottom).
3. If possible, install the device below the lower measurement connection so that the lower differential pressure pipe is always filled with liquid.
4. For level measurement in closed containers with steam layering, a condensing vessel ensures a filled differential pressure pipe and thus constant pressure on the minus side.
5. Fill up the differential pressure pipe in a cold state with water via the condensing vessel or via the valve block.
6. For the device configuration, see chapter 8 "Configuration", Page 49.

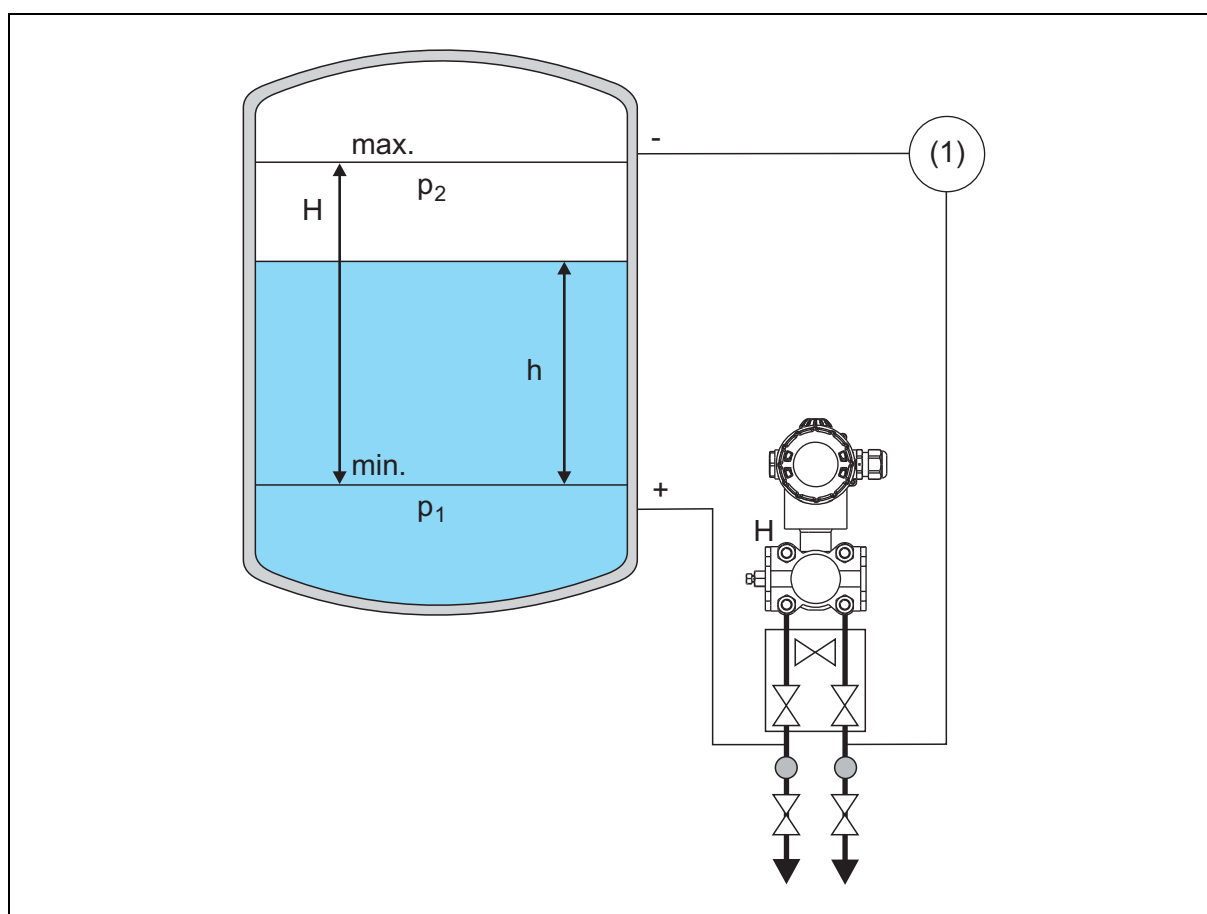

(1) Condensing vessel  
 h (filling level) 4 to 20 mA



### NOTE!

Install the condensing vessel at the same height as the extraction support and at the same distance to the measuring device.

# 5 Mounting

## 5.8.3 Measuring arrangement for steam layering and a measuring range of 0 to 1 bar

The device must be installed according to the following diagram:

1. Always connect the plus side (marked "H") via a differential pressure pipe on the upper process connection (PLUS input is at top).
2. Always connect the minus side (zero) via a differential pressure pipe below the maximum filling level (MINUS input is at bottom).
3. If possible, install the device below the lower measurement connection so that the lower differential pressure pipe is always filled with liquid.
4. For level measurement in closed containers with steam layering, a condensing vessel ensures a filled differential pressure pipe and thus constant pressure on the minus side.
5. Fill up the differential pressure pipe in a cold state with water via the condensing vessel or via the valve block.
6. For the device configuration, see chapter 8 "Configuration", Page 49.

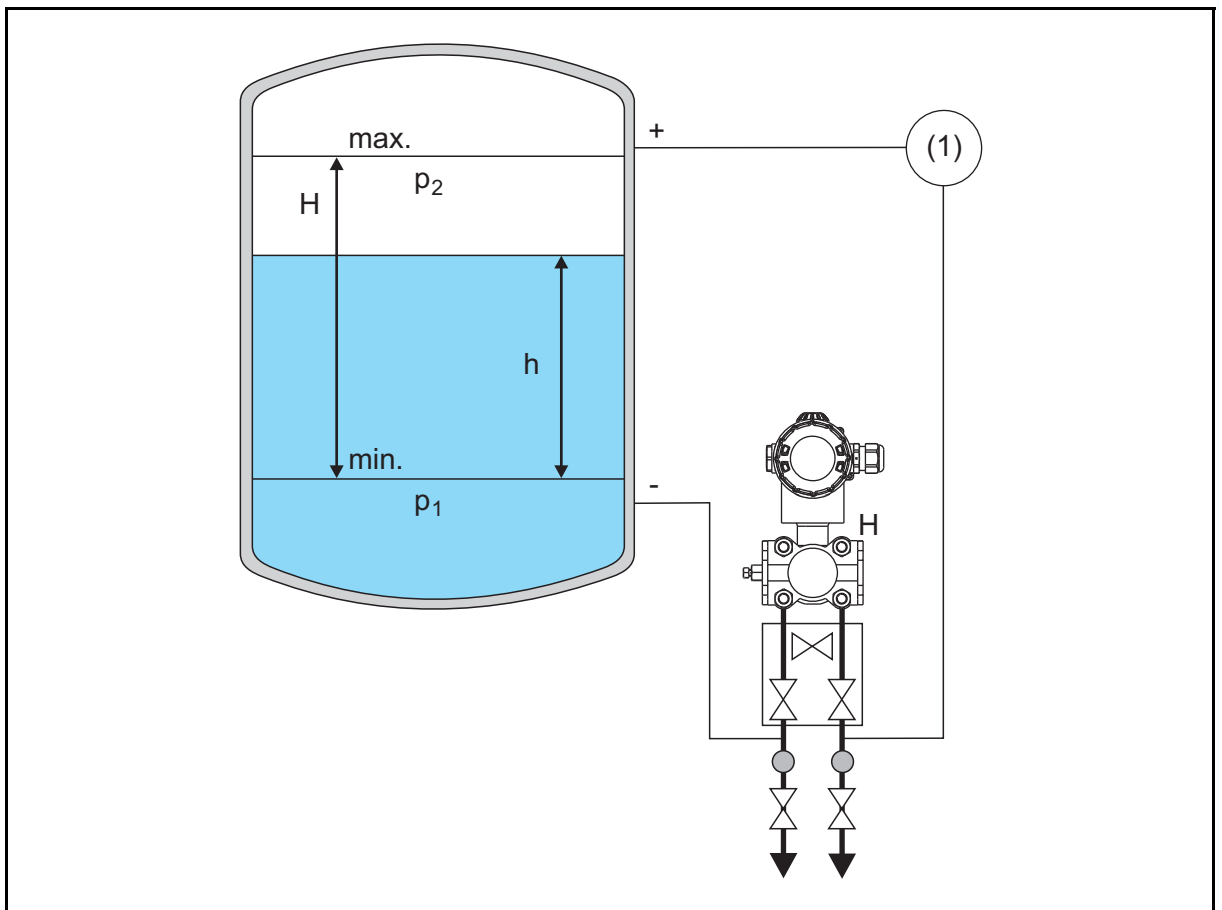

- (1) Condensing vessel  
h (filling level) 4 to 20 mA



### NOTE!

Install the condensing vessel at the same height as the extraction support.



## 5.9 Assembly in the explosion area

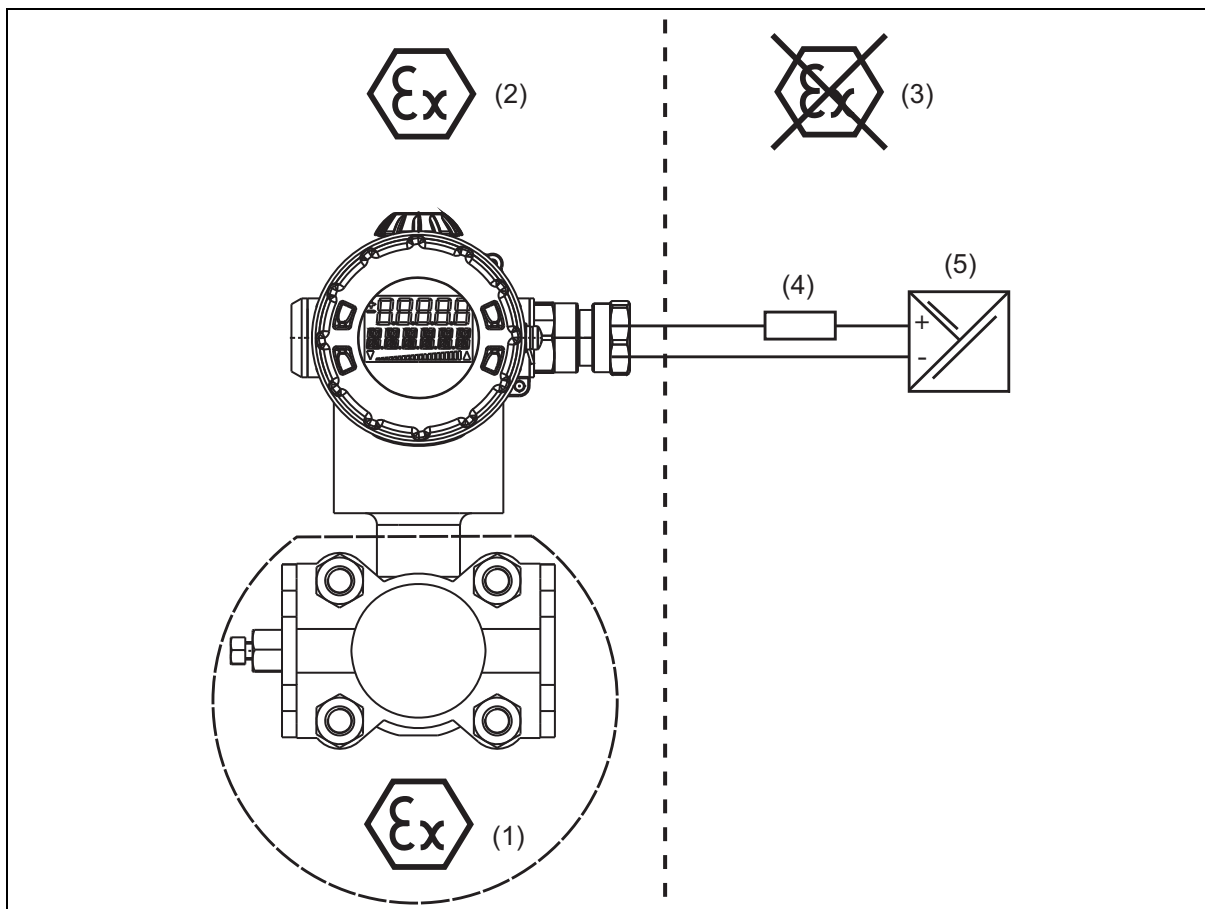

- (1) Potentially explosive area zone 0/20
- (2) Potentially explosive area zone 1/21
- (3) Non-potentially explosive area
- (4) Burden (optional for HART® interface)
- (5) Voltage supply

## 5 Mounting

---

## 6.1 Installation notes



### DANGER!

The electrical connection must only be implemented by suitably qualified personnel!  
 Ground the device!  
 Only use cable entries or glands, blanking plugs, etc., that are suitable for the "explosion-proof enclosure d" protection type!  
 The cables or leads must be suitable for the ambient conditions!  
 Connection openings on the device that are open must be closed with suitable blankingplugs!

Applicable requirements must be followed for the electrical connection, especially in a potentially explosive atmosphere:

Regulation concerning electrical systems in areas with an explosion hazard (Elex V).

Requirement for project planning, selecting and setting up electrical systems in areas with an explosion hazard (IEC 60079-14).

EC-type examination certificate

Electromagnetic compatibility meets the requirements of EN 61326.

The differential pressure transmitter is suitable for use in SELV or PELV current circuits according to protection rating 3.

Apart from faulty installation, incorrect settings on the device may also affect the proper functioning of the subsequent process or lead to damage. You should therefore always provide safety equipment that is independent of the device and it should only be possible for qualified personnel to make settings.

### Conductor cross-sections and ferrules

	Permissible cross-section
<b>Without ferrule</b> (for rigid cable only)	0.2 to 1.5 mm <sup>2</sup> AWG 24 to 16
<b>With ferrule</b> (for rigid or flexible cable)	0.25 to 0.75 mm <sup>2</sup>



### DANGER!

**The JUMO interface must not be used in the explosion-proof area!**

- ▶ The differential pressure transmitter's voltage supply may not exceed or fall below the following values:  
 DC 12 to 36 V

## 6 Installation

---

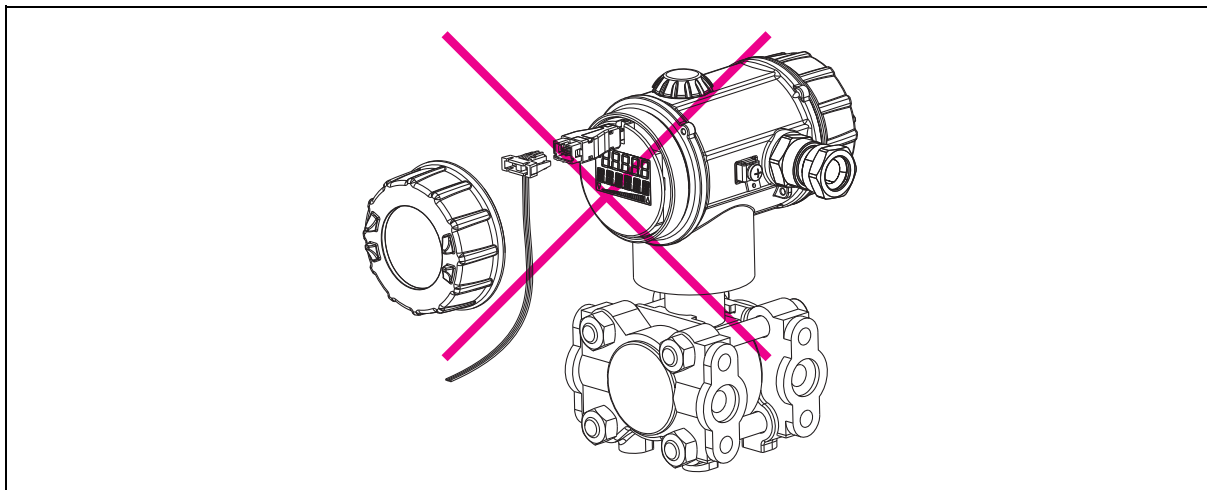

**NOTE!**

Connecting the HART® communicator or the HART® modem is optional. A minimum burden must be present on the signal circuit in order to facilitate error-free communication, see the following pages.

---

## 6.1.1 Connection diagram "Ex"

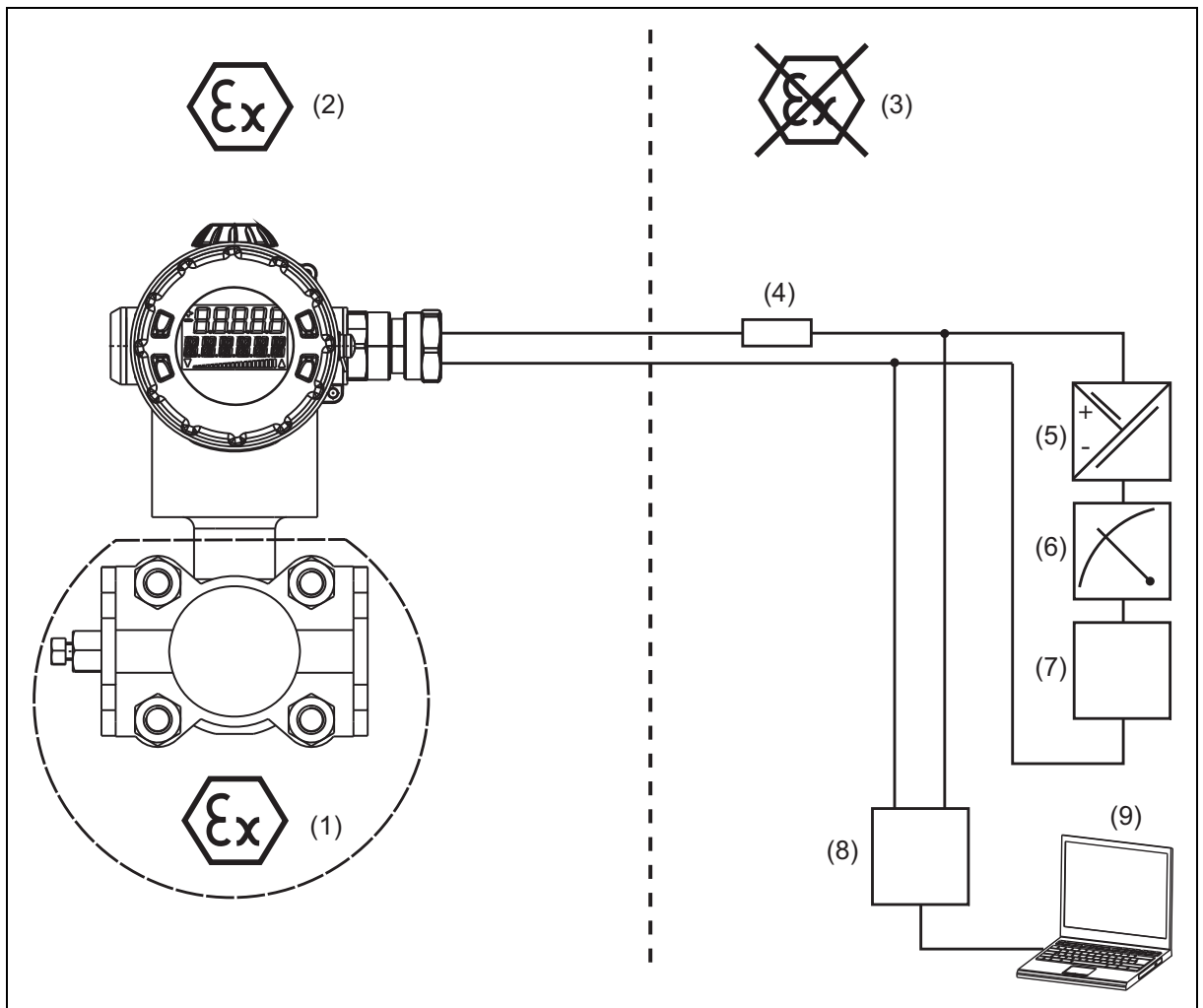

- (1) Potentially explosive area zone 0/21
- (2) Potentially explosive area zone 1/21
- (3) Non-potentially explosive area
- (4) Burden for HART®  $\leq (U_B - 12 \text{ V}) \div 0.022 \text{ A}$ ;  
additional: min. 250  $\Omega$ , max. 1100  $\Omega$
- (5) Voltage supply
- (6) Indicating device or recorder, controller, PLC, etc.
- (7) Further devices
- (8) HART® modem
- (9) PC or notebook

# 6 Installation

## 6.2 Device with cable gland

### General information

- Cables or lines must be suitable for the environmental influences
- Cable diameters of 7.5 to 11.9 mm are admissible
- Max. conductor cross section of 1.5 mm<sup>2</sup>
- Lay the signal lines isolated from cables with a voltage of > 60 V
- Use protected cables with twisted cores
- Keep away from large, electrical plants
- The full specification according to HART® can only be reached with a shielded cable.

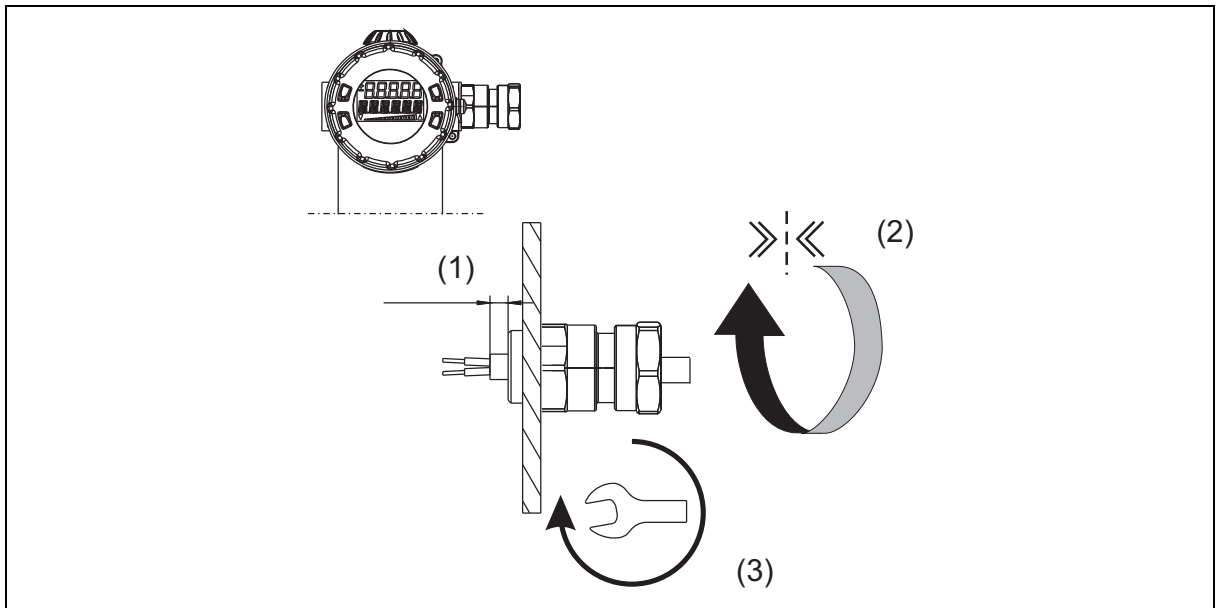

- (1) The connecting cable must reach at least 5 mm into the housing
- (2) Tighten the screw connection by hand until resistance is felt
- (3) Tighten the screw connection using a wrench (approx. 3/4 to 1 rotation)

## Connection

1. To unscrew the rear housing lid, see chapter 5.2 "Unscrew the front ring or case lid", Page 21
2. Ground the device.
3. For connecting the connecting cables, see the following figure:

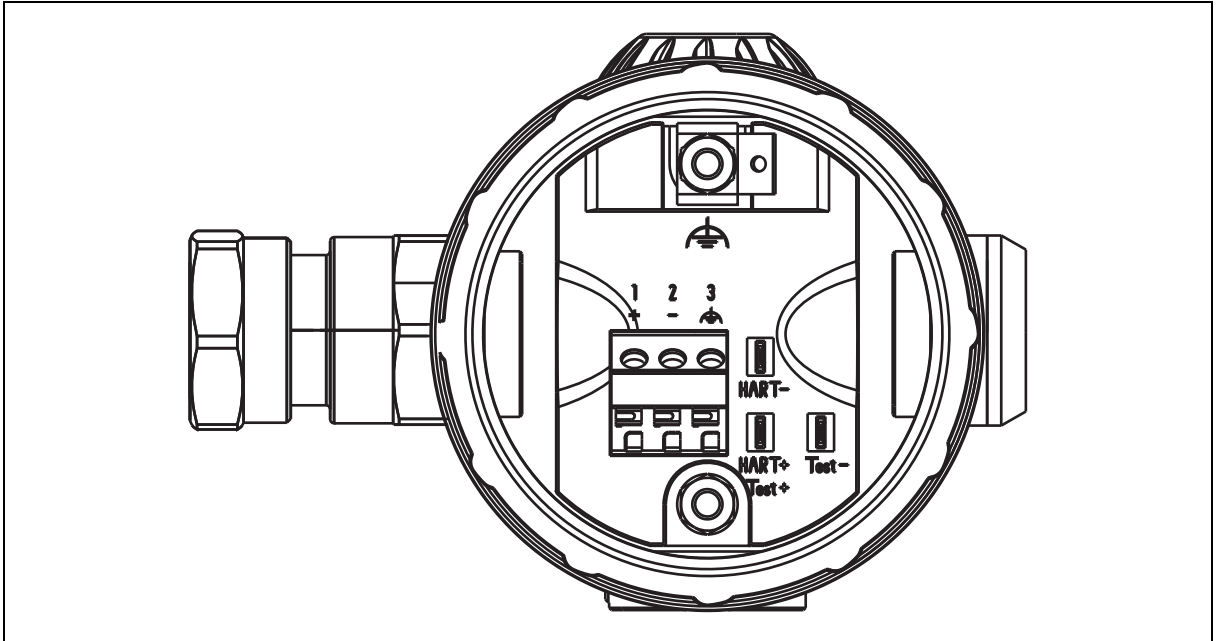

### CAUTION!

Once electrical connection is complete, re-tighten the locking screw of the housing cover!

Connection		Terminal assignment
Voltage supply	DC 12 to 36 V	1 L+ 2 L-
Output 4 to 20 mA, two-wire Load-independent current: 4 to 20 mA In voltage supply		1 L+ 2 L-
Test connection for current output Internal resistance of the ammeter $\leq 10 \Omega$		TEST + TEST -
Test connection for HART® The burden must be present!		HART + HART -
FE (functional grounding conductor)		3
Grounding or potential equalization		Outside of the housing

# 6 Installation

## Operation and testing

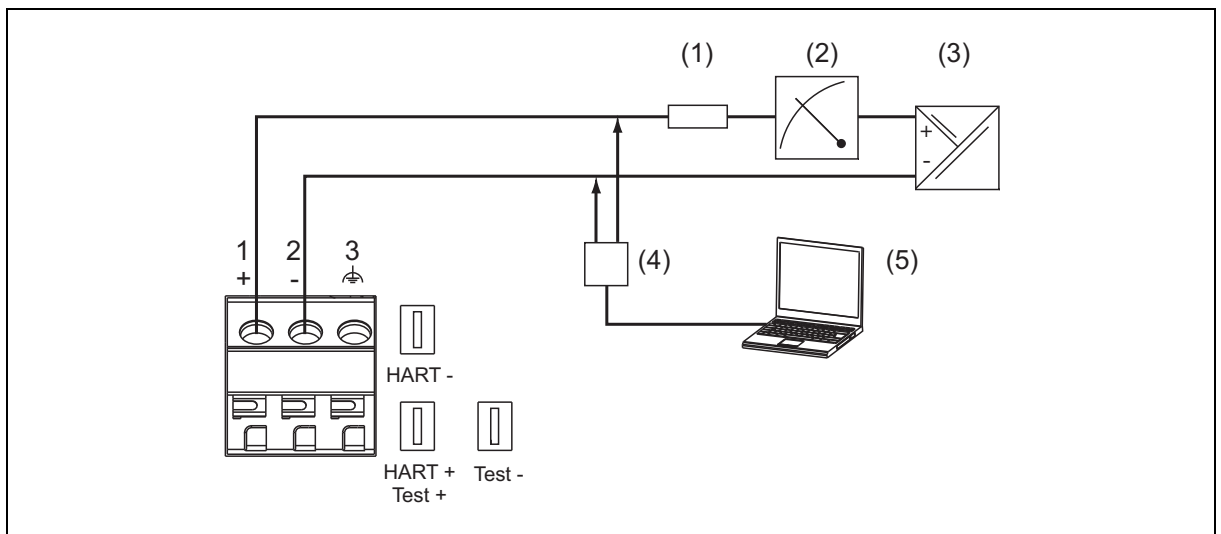

- (1) Total burden:  $Burden \leq (U_B - 12 \text{ V}) \div 0.022 \text{ A}$ ;  
for HART® additional: min. 250  $\Omega$ , max. 1100  $\Omega$
- (2) Indicating device or recorder, controller, PLC, etc.
- (3) Voltage supply DC 12 to 36 V
- (4) HART® modem
- (5) PC or notebook



## 7.1 Display

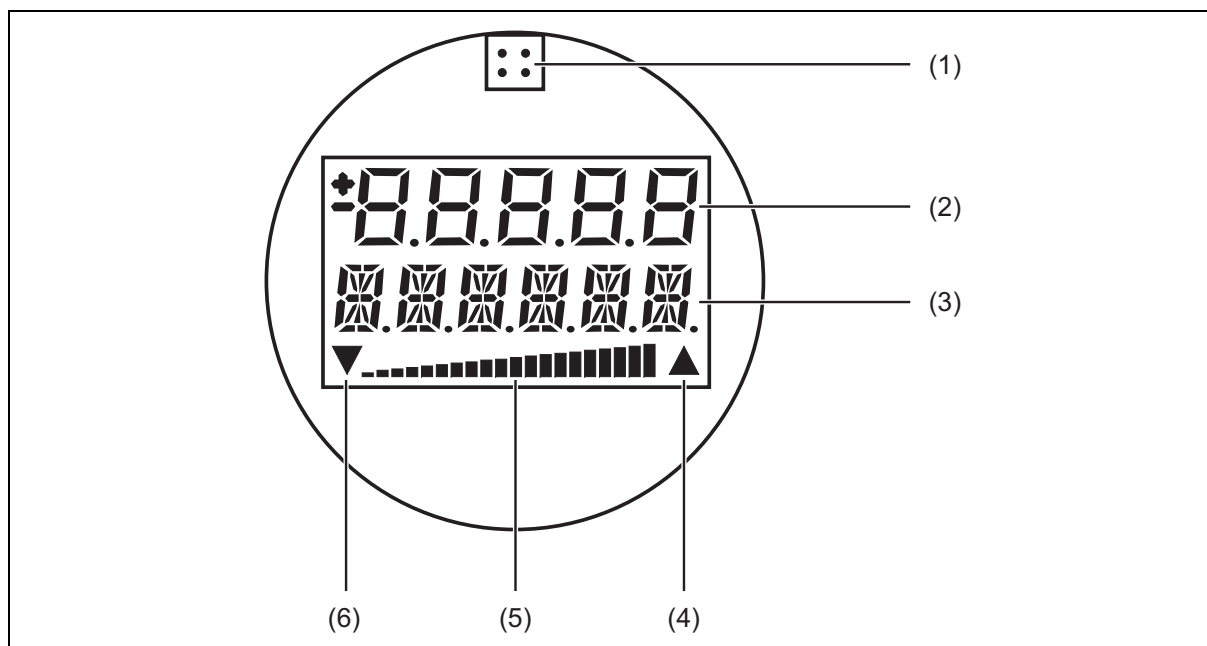

- (1) Socket for JUMO setup interface (behind a cover)
- (2) Measured value
- (3) Measuring unit
- (4) Overage
- (5) Percentage control of the measuring range
- (6) Underrange

# 7 Operation

## 7.2 Operation with rotary knob or with setup programm

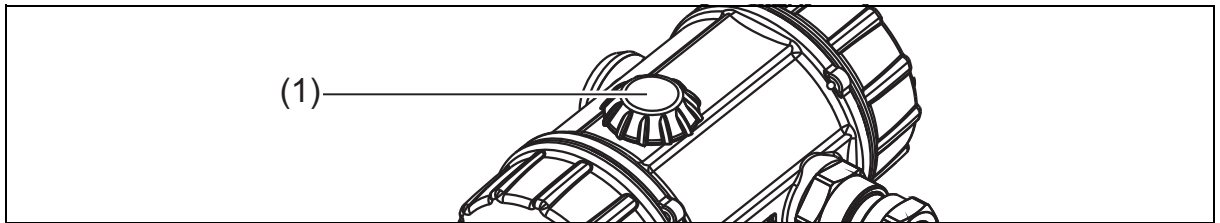

(1) Rotary knob

The device is operated either

- with the rotary knob (1) or
- via the optional setup program or
- via the HART® interface, e.g. with a handheld or PC program.



### NOTE!

Alternatively, for operation via a rotary knob, all actual values and parameters can very easily be displayed or adjusted by means of the setup program.

Furthermore, the setup program offers an array of useful additional functions, e.g.:

- Recording the measured values
- Graphical view of temperature and pressure
- Detailed diagnostic messages
- Display of the complete order code and the device configuration (can be printed out, e.g. for project documents or follow-up orders)

The setup program can address the device via the following interfaces:

- JUMO setup interface  
The PC interface cable with USB/TTL converter (USB transmitter cable) is required to connect the PC to the device, part no. 00456352
- HART® interface  
A HART® modem is required to connect the PC to the device, part no. 00443447

### Rotating and pressing

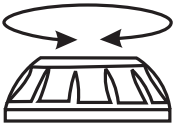
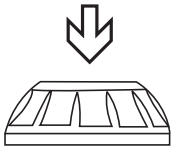
	Rotate Select parameter or set values
	Press Confirm parameter or values

### 7.3 The level concept

#### Two levels

Operation is on two levels:



#### NOTE!

After the device is turned on, it is on the display level. You can go to the parameter level through the following operation.

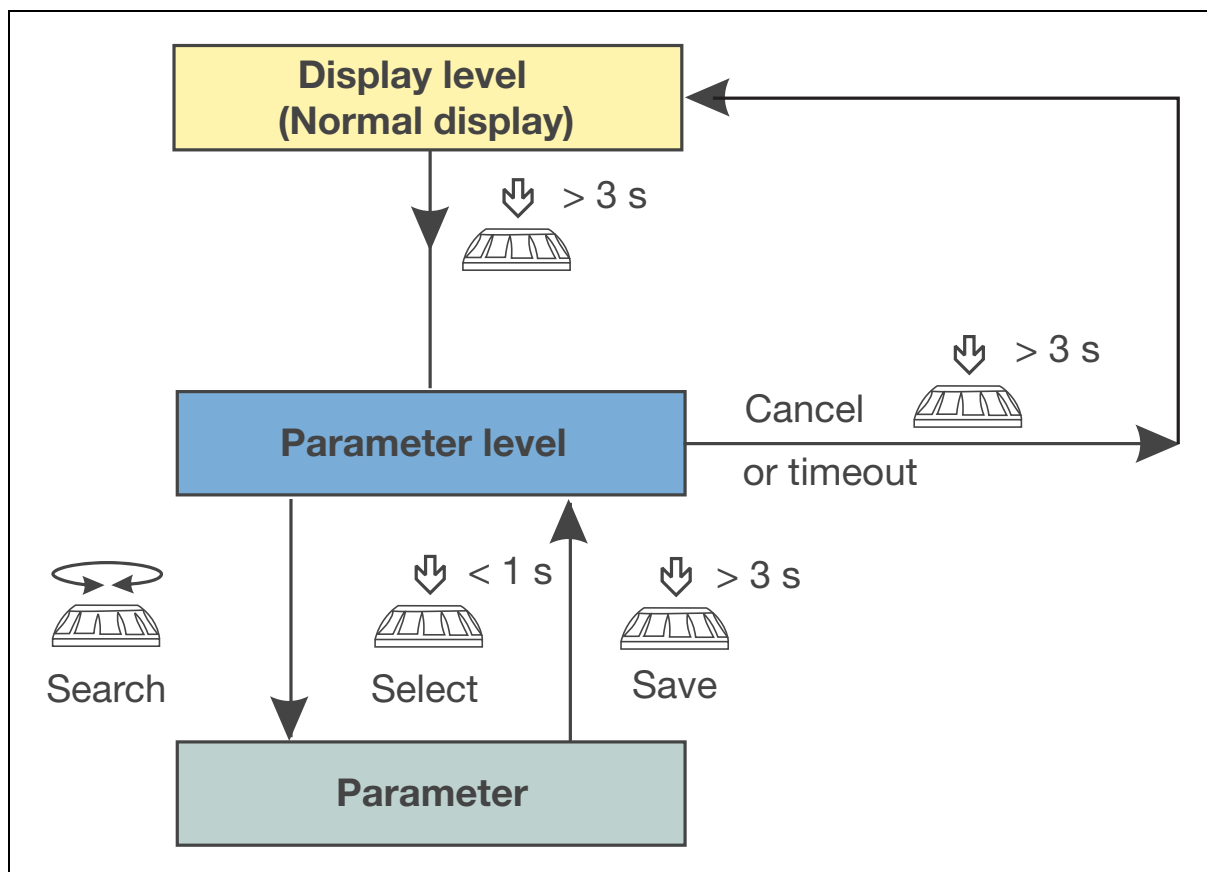





# 7 Operation

## 7.3.1 The display level

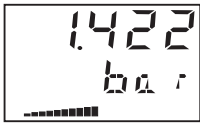
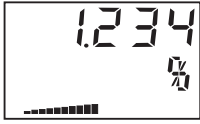
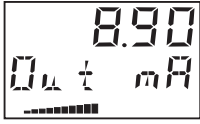











The measured pressure and other values are displayed at the display level. The output current is shown in % as a bar chart in the third line of the display.

It is not possible to change parameters at the display level!



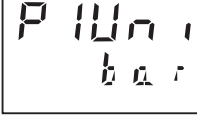





Action	Display (example)	Explanation
		Displays the pressure with measuring unit
		Displays the measured value in % or measured value scaled with a choice of measuring unit
		Displays the calculated output current in mA.
		Displays the sensor temperature in °C or °F.
		Displays the stored minimum pressure in the selected measuring unit
		Displays the stored maximum pressure
		Displays the pressure value and the sensor temperature in the selected measuring units

## 7.3.2 The parameter level

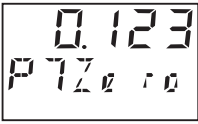



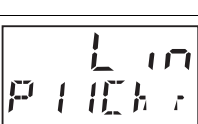
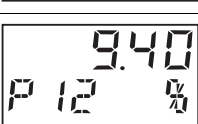

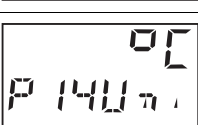
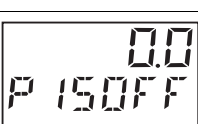
The device parameters can be displayed and changed at the parameter level.

Action	Display (example)	Explanation	Selection <sup>a</sup>
		<b>P min</b> Stored minimum pressure	Reset by  > 3 seconds 
		<b>P max</b> Stored maximum pressure	Reset by  > 3 seconds 
		<b>P0 Den</b> "Density" Density correction	0.01 to <b>1.00</b> to 99.99
		<b>P1 Uni</b> "Unit" Pressure measuring unit	inH2O inHG ftH2O mmH2O mmHG PSI <b>bar</b> mbar kg/cm2 kPa TORR MPa mH2O
		<b>P2 mA</b> Measuring range Lower range value	<b>4.00</b> to 20.00 mA
		<b>P3 mA</b> Measuring range Upper range value	4.00 to <b>20.00</b> mA
		<b>P4 sec</b> Attenuation	<b>0.00</b> to 100.0 s
		<b>P5 RS</b> "Range start" Measuring range Lower range value	Nominal measuring range

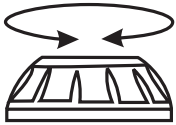
## 7 Operation

Action	Display (example)	Explanation	Selection <sup>a</sup>
		<b>P6 RE</b> "Range end" Measuring range Upper range value	Nominal measuring range
		<b>P7 Zero</b> Zero point adjustment	Current pressure
		<b>P8 mA</b> Current generator	3.60 to <b>4.00</b> to 21.60 mA
		<b>P9 Err</b> Current in case of malfunction	ErLo = 3.6 mA <b>ErHi = 21.6 mA</b> LAsT = last value
		<b>P10 Key</b> Key lock	<b>0</b> = no lock LA = all, interface released L0 = all, without measurement start LS = alle, ohne Messanfang und -ende LALL = alle, inkl. Schnittstelle
		<b>P11 Chr</b> Characteristic line "Characteristic"	<b>Lin = linear</b> SLin = linear bis Beginn Radizierung SoFF = off until start of square root extraction
		<b>P12 %</b> Insertion point of Radizierung	5.0 to <b>9.4</b> to 15.0 % vom Ausgangsstrom
		<b>P13 SWV</b> Software version	Editing not possible
		<b>P14 Uni</b> Temperature measuring unit	°C/°F
		<b>P15 OFF</b> Pressure value offset (zero offset)	Nominal measuring range

## 7 Operation

Action	Display (example)	Explanation	Selection <sup>a</sup>
		<b>P16 SCS</b> Scaling start „Scaling start“	-9999 to <b>0</b> to +9999
		<b>P17 SCE</b> Scaling end „Scaling end“	-9999 to <b>100</b> to +9999
		<b>P18 SCD</b> Decimal place scaling „Scaling decimal point“	<b>Auto = automatic</b> 0 = no decimal place 1 = 1 decimal place 2 = 2 decimal places 3 = 3 decimal places
		<b>P19 %</b> Scaling unit	<b>% (default setting)</b> kg/sec kg/min kg/h t/min t/h l/sec l/min l/h m3/sec m3/min m3/h L m3 UsrTEXT
		<b>P20 h</b> Operating hours	Editing not possible

<sup>a</sup> Default settings are shown in **bold**.

## 7 Operation

---



## 8.1 Data flow diagram

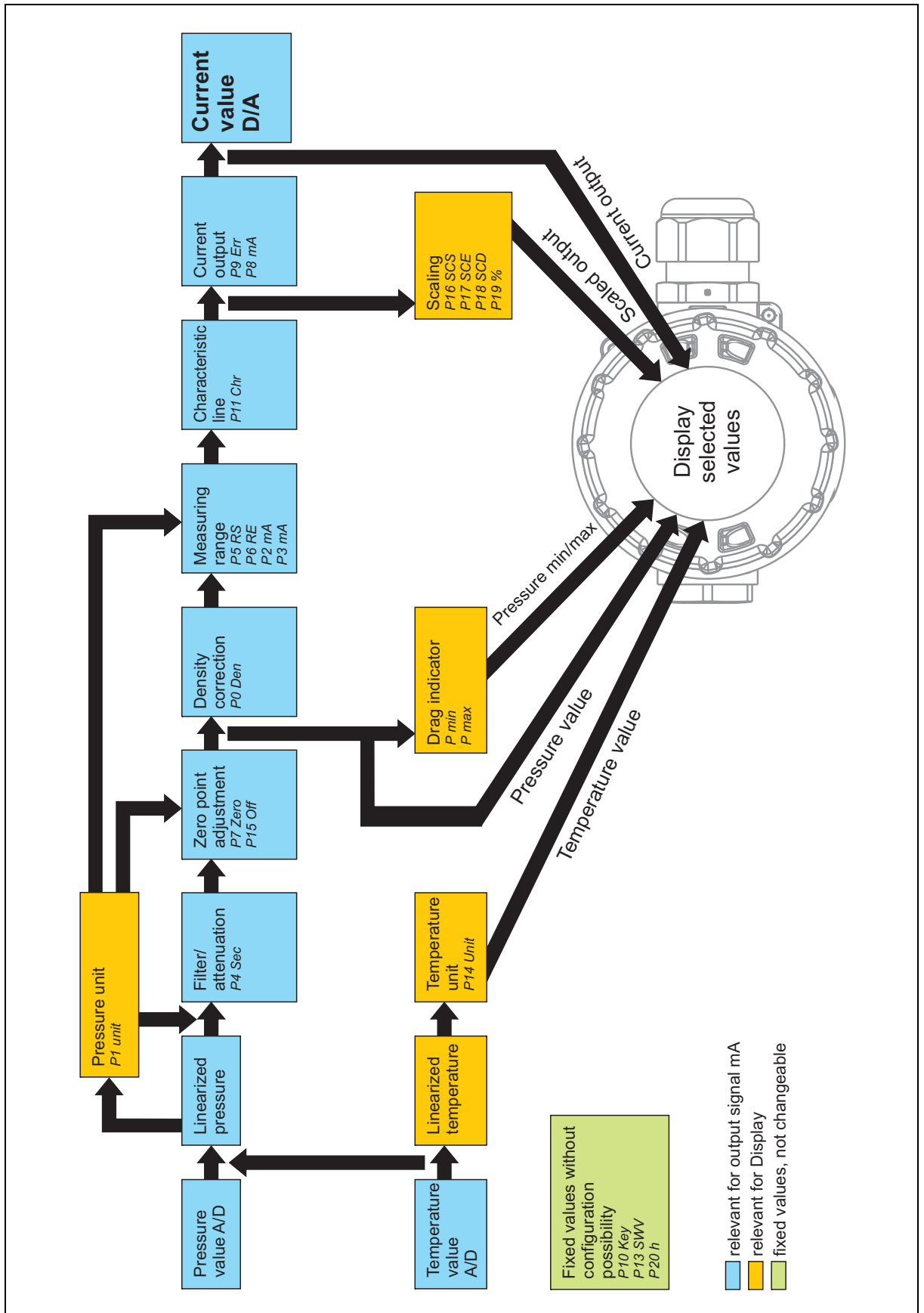

# 8 Configuration

---

## 8.2 Description of the possible configurations

**P0 Den      Density correction**

Configuration of the density of the medium to be measured

This may, for example, be relevant for the level measurement in order to display the correct filling height from the measured pressure.



**CAUTION!**

**The set value should remain at the value 1 and should be changed in exceptional cases.**

---

**P1 Uni      Pressure measuring unit**

The pressure value unit can be configured here. The pressure value unit is shown on the display and can be taken from the HART® protocol.

**P2 mA      Measuring range lower range value**

Configuration of the device (measuring range) with pressure specification

If the tank is empty, the start point (zero point) of the pressure/level measurement can be set here. The advantage of this procedure: The device is immediately configured for the application (e.g. tank).



**CAUTION!**

**No further density corrections may be configured. No other values may be entered under P5 RS.**

---

**P3 mA      Measuring range upper range value**

Configuration of the device (measuring range) with pressure specification

If the tank is full, the end point (full) of the pressure/level measurement can be set here. The advantage of this procedure: The device is immediately configured for the application (e.g. tank).



**CAUTION!**

**No further density corrections may be configured. No other values may be entered under P6 RE.**

---

**P4 Sec      Attenuation**

Time constant defined in seconds

Depending on the default setting, it is ensured that the measured value responds with a delay to short, fast pressure changes.

**P5 RS      Measuring range lower range value**

Configuration of the device (measuring range) without pressure specification

Any values can be entered here as the lower range value. It is important when, for example, a differential pressure measurement with a diaphragm seal is attached to an application (e.g. filling level) and no configuration with a pressure specification can be performed.

There is a calculation example available under chapter 8.4 "Level measurement configuration without a pressure specification", Page 55.



**CAUTION!**

**No further density corrections may be configured. No other values may be entered under P2 mA.**

---

**P6 RE      Measuring range upper range value**

Configuration of the device (measuring range) without pressure specification

Any values can be entered here as the upper range value. It is important when, for example, a differential pressure measurement with a diaphragm seal is attached to an application (e.g. filling level) and no configuration with a pressure specification can be performed. There is a calculation example available under chapter 8.4 "Level measurement configuration without a pressure specification", Page 55.



### CAUTION!

**No further density corrections may be configured. No other values may be entered under P3 mA.**

---

**P7 Zero**     **Zero point adjustment** (only for relative pressure)

The applied pressure is stored as a zero point.



### CAUTION!

**Only perform this configuration if it is certain that the zero point is actually present on the device (e.g. after installing or correcting the position of the device). Otherwise a zero offset can also be configured with this. The zero offset is stored as an offset (P15).**

**Zero point adjustment is not possible with absolute pressure sensors.**

---

**P8 mA**     **Current generator**

The device outputs a freely adjustable current value. The analog output has no reference to the pressure measurement. The actual pressure measurement continues to be performed in the background and can be queried via the interfaces. If the current generator was manually started via P8, this is represented by an icon next to P8 and can also be stopped again by exiting P8.

**P9 Err**     **Current in case of malfunction**

Option for setting which fault current the device should output in case of a malfunction. The default value is set to 21.6 mA according to NAMUR NE 43.

**P10 Key**     **Key lock**

This makes it possible to set a keypad lock in different stages. This is a safety feature to prevent accidental, but also intentional configuration changes to the device.



### NOTE!

To cancel a set lock (LA, L0, LS), the user must press the P-key for longer than 5 s in the "Current in case of malfunction" (P9 Err) display screen.

The "LALL" lock can only be set or canceled in the setup program.

---

# 8 Configuration

**P11 Chr Characteristic line**

This point is not relevant for relative/absolute pressure measurement and should therefore not be configured. It can be used with the differential pressure measurement to implement a flow measurement.

With P11, the characteristic line of the preset value  $Lin = \text{pressure proportional}$  can be re-configured to a square root extraction characteristic line  $SLin$  or  $SOff = \text{flow proportional}$ . For the flow measurement, parameter P12 = insertion point relevant, below the characteristic line for low flow suppression either linearly connected ( $SLin$ ) or completely disabled ( $SOff$ ).

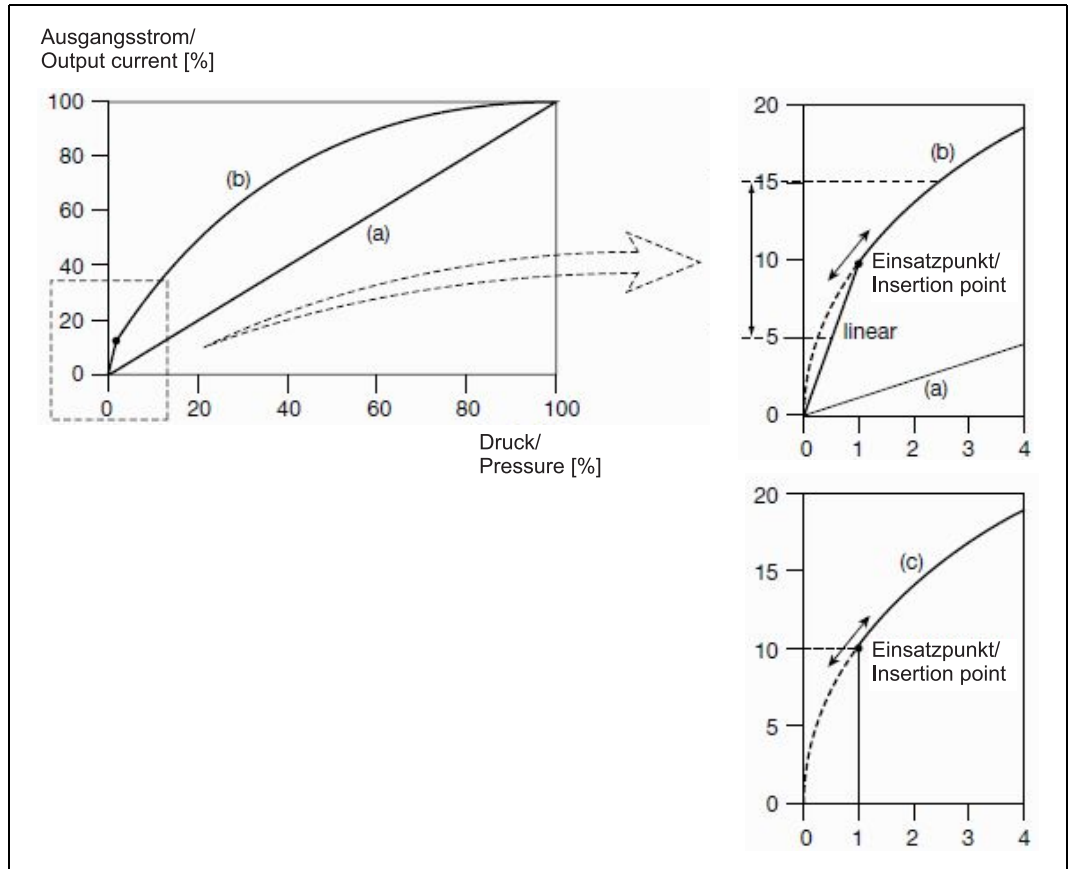

- (a) = Lin = linear
- (b) = SLin = square-root, linear up to insertion point
- (c) = SOFF = square-root, disconnected up to insertion point

**P12 % Insertion point of the square root extraction**

This point is not relevant for relative/absolute pressure measurement and should therefore not be configured. It can be used with the differential pressure measurement to implement a flow measurement. The insertion point of the square root extraction sets the start point for the flow measurement.

**P13 SWV Software version**

For information only  
 No configuration option

**P14 Uni Temperature measuring unit**

The temperature value can be read on the display or via the HART® signal. There is no option to transmit the temperature value via a 4 to 20 mA signal. The temperature unit can be configured here.

- P15 Off**     **Pressure value offset**  
The offset value of the pressure value (relative or absolute pressure) is shown in figures here (e.g. after the zero point adjustment). The values listed there should only be corrected in exceptional cases as it is possible to manually readjust an offset there. Please contact the manufacturer for this.
- P16 SCS**     **Scaling start**  
Configuration option to show the pressure value assignment on other physical values/units. For example, the pressure value applied on the device can be scaled to liters and other units (see P19). The scaling start is set here (e.g. 0).
- P17 SCE**     **Scaling end**  
Configuration option to show the pressure value assignment on other physical values/units. For example, the pressure value applied on the device can be scaled to liters and other units (see P19). The scaling end is set here (e.g. 100).
- P18 SCD**     **Decimal place scaling**  
Configuration option to show the pressure value assignment on other physical values/units. For example, the pressure value applied on the device can be scaled to liters and other units (see P19). The scaling decimal place is set here.
- P19 %**        **Scaling unit**  
Configuration option to show the pressure value assignment on other physical values/units. The scaling unit is set here.
- P20 h**         **Operating hours**  
For information only  
No configuration option

# 8 Configuration

## 8.3 Level measurement configuration with a pressure specification - recommended (tank empty, tank full)

The following description applies to level measurements of all measuring ranges with or without a diaphragm seal.

### With rotary knob operation (parameter level)

**Swap from display level to parameter level**, see chapter 7.3 "The level concept", Page 43

The following configuration steps should be taken:

- P1 Measuring unit, e.g. mbar
- P2 Measuring range lower range value: 4 mA (configuration with empty tank)
- P3 Measuring range upper range value: 20 mA (configuration with full tank)
- P4 Attenuation: 0
- P14 Temperature measuring unit (only for displaying or as HART® signal): °C
- P16 Scaling start: scaling on the tank, e.g. in liters: 0
- P17 Scaling end: scaling on the tank, e.g. in liters: 200
- P19 Scaling unit: L (liters)

**Swap from parameter level to display level**

### With JUMO setup program

**Extras**      **Extras: Online operation\_measuring start with pressure transmitter (zero)** – with empty tank  
Confirm transfer.

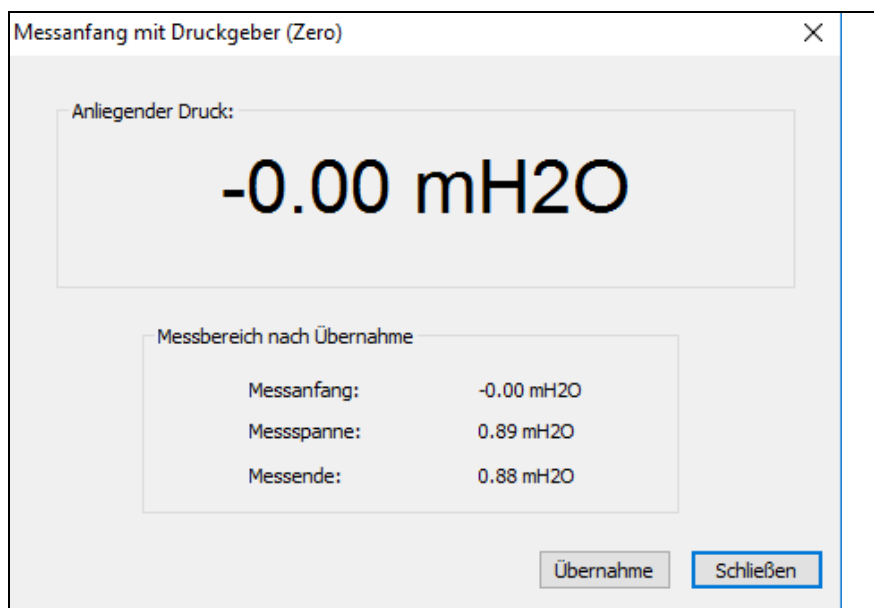

**Extras**      **Extras: Online operation\_measuring end with pressure transmitter (span)** – with full tank  
Confirm transfer.



### NOTE!

No zero point adjustment should be performed when configuring the level measurement with a pressure specification.

## 8.4 Level measurement configuration without a pressure specification

### 8.4.1 With a diaphragm seal in closed containers with a measuring range of 0 to 1 bar



**NOTE!**

The filling oil in the diaphragm seal used has an influence on the configuration of the device and therefore always needs to be considered in the calculation.

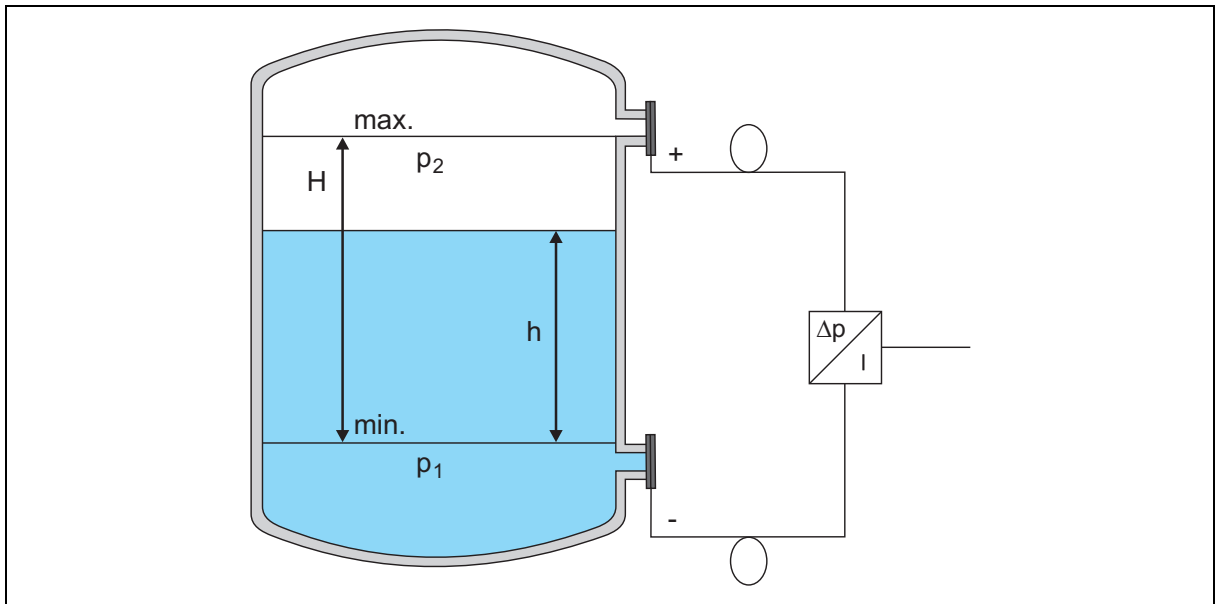

**Range start (4 mA):**

Measuring range lower range value P5 [mbar] =  $H \times \rho_{oil} \times g \times 0,01$

**Range end (20 mA):**

Measuring range upper range value P6 [mbar] =  $(H \times \rho_{oil} - h \times \rho_{liq}) \times g \times 0,01$

**Legend:**

H	[mm]	=	Vertical distance of the diaphragm seal
h	[mm]	=	Max. level of the measured liquid, $0 < h \leq H$
$\rho_{oil}$	[g/cm <sup>3</sup> ]	=	0.96, density of the oil in the capillary
$\rho_{liq}$	[g/cm <sup>3</sup> ]	=	Density of the measured liquid
g	[m/s <sup>2</sup> ]	=	9.81, gravitational acceleration

**Example:**

Tank height = 10 m

H [mm] = 9000

h [mm] = 8000

$\rho_{liq}$  [g/cm<sup>3</sup>] = 1.00, density of the water, 4 °C

Measuring range lower range value P5 [mbar] =  $9000 \times 0.96 \times 9.81 \times 0.01 = 847.6$

Measuring range upper range value P6 [mbar] =  $(9000 \times 0.96 - 8000 \times 1.00) \times 9.81 \times 0.01 = 62.8$

# 8 Configuration

## With rotary knob operation (parameter level)

**Swap from display level to parameter level**, see chapter 7.3 "The level concept", Page 43

The following configuration steps should be taken:

- P1 Unit, e. g. mbar
- P4 Attenuation: 0
- P5 Measuring range lower range value: 847.6, see example calculation
- P6 Measuring range upper range value: 62.8, see example calculation
- P14 Temperature measuring unit (only for displaying or as HART® signal): °C
- P16 Scaling start: scaling on the tank, e.g. in liters: 0
- P17 Scaling end: scaling on the tank, e.g. in liters: 200
- P19 Scaling unit: L (liters)

## Swap from parameter level to display level

## With JUMO setup program

### Data transfer from the device

Editing Maintenance

The following dialog window opens: "Maintenance":

**Instandhaltung**

**Messbereich**

Maßeinheit (P01): mH2O

Messanfang (P05): 0.000 mH2O

Messende (P06): 1.500 mH2O

Offset (P15): -0.210 mH2O

**Kennlinie**

Dämpfung (P04): 2.5 sec

Kennlinie (P11): Linear

Einsatzpunkt (P12): 9.4 %

**Skalierung**

Anfang (P16): 0.00

Ende (P17): 20.00

Maximale Nachkommastelle (P18): Automatik

Einheit (P19): l

Kundenspezifisch:

**Datum**

Messstellendatum: 01.01.2008 Heute

OK Abbrechen

- P01 Measuring unit, e.g. mbar
- P04 Attenuation: 2.5
- P05 Measuring range lower range value: 847.6, see example calculation
- P06 Measuring range upper range value: 62.8, see example calculation
- P11 Characteristic line: linear
- P14 Temperature measuring unit (only for displaying or as HART® signal): °C
- P16 Scaling start: scaling on the tank, e.g. in liters: 0
- P17 Scaling end: scaling on the tank, e.g. in liters: 200
- P18 Maximum decimal place: automatic
- P19 Scaling unit: L (liters)



After entering the desired values: Start data transfer to device.



## CAUTION!

A zero point adjustment should generally not be performed (e.g. when the tank is empty) in a measuring range of 0 to 1 bar.

### 8.4.2 With a diaphragm seal in closed containers with $\pm$ measuring ranges

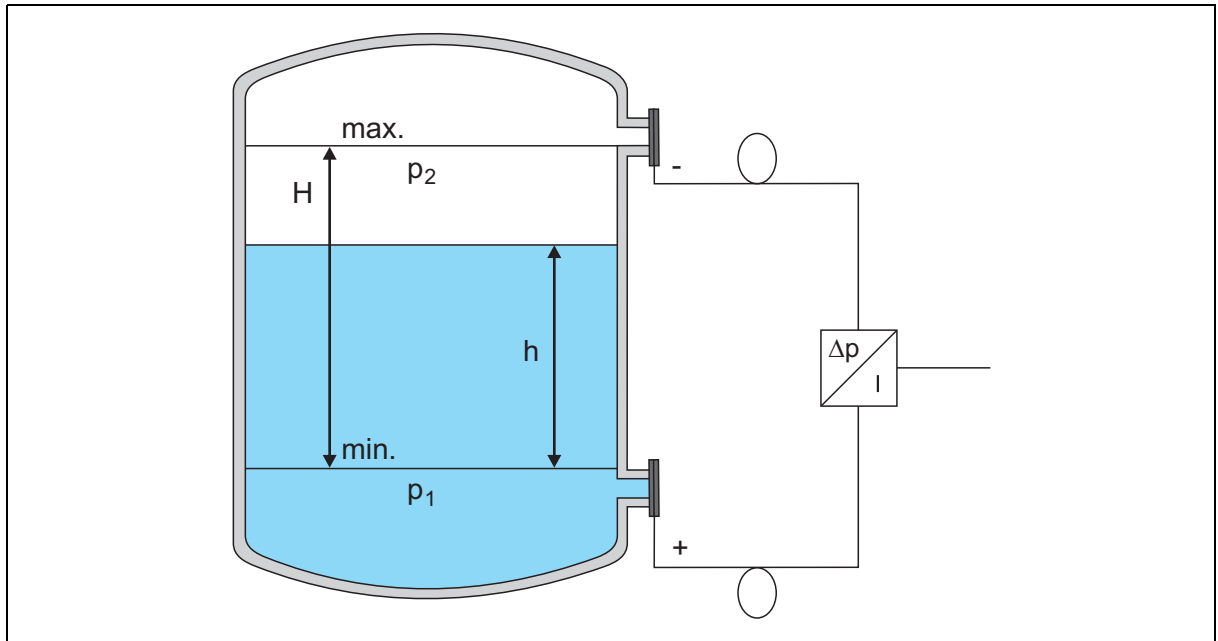

#### Range start (4 mA):

$$\text{Measuring range lower range value P5 [mbar]} = -(H \times \rho_{\text{oil}} \times g \times 0,01)$$

#### Range end (20 mA):

$$\text{Measuring range upper range value P6 [mbar]} = -(H \times \rho_{\text{oil}} - h \times \rho_{\text{liq}}) \times g \times 0,01$$

#### Legend:

H	[mm]	=	Vertical distance of the diaphragm seal
h	[mm]	=	Max. level of the measured liquid, $0 < h \leq H$
$\rho_{\text{oil}}$	[g/cm <sup>3</sup> ]	=	0.96, density of the oil in the capillary
$\rho_{\text{liq}}$	[g/cm <sup>3</sup> ]	=	Density of the measured liquid
g	[m/s <sup>2</sup> ]	=	9.81, gravitational acceleration

#### Example:

Tank height		=	10 m
H	[mm]	=	9000
h	[mm]	=	8000
$\rho_{\text{liq}}$	[g/cm <sup>3</sup> ]	=	1.00, density of the water, 4 °C
Measuring range lower range value P5	[mbar]	=	$-(9000 \times 0.96 \times 9.81 \times 0.01) = -847.6$
Measuring range upper range value P6	[mbar]	=	$-(9000 \times 0.96 - 8000 \times 1.00) \times 9.81 \times 0.01 = -62.8$

# 8 Configuration

## With rotary knob operation (parameter level)

**Swap from display level to parameter level**, see chapter 7.3 "The level concept", Page 43

The following configuration steps should be taken:

- P1 Unit, e. g. mbar
- P4 Attenuation: 0
- P5 Measuring range lower range value: 62.8, see example calculation
- P6 Measuring range upper range value: 847.6, see example calculation
- P14 Temperature measuring unit (only for displaying or as HART® signal): °C
- P16 Scaling start: scaling on the tank, e.g. in liters: 0
- P17 Scaling end: scaling on the tank, e.g. in liters: 200
- P19 Scaling unit: L (liters)

## Swap from parameter level to display level

## With JUMO setup program

### Data transfer from the device

Editing Maintenance

The following dialog window opens:

The screenshot shows a dialog window titled "Instandhaltung" with a close button (X) in the top right corner. The window is divided into four main sections: "Messbereich", "Kennlinie", "Skalierung", and "Datum".

- Messbereich:** Contains four input fields: "Maßeinheit (P01): mH2O" (dropdown), "Messanfang (P05): 0.000 mH2O", "Messende (P06): 1.500 mH2O", and "Offset (P15): -0.210 mH2O".
- Kennlinie:** Contains three input fields: "Dämpfung (P04): 2.5 sec", "Kennlinie (P11): Linear" (dropdown), and "Einsatzpunkt (P12): 9.4 %".
- Skalierung:** Contains four input fields: "Anfang (P16): 0.00", "Ende (P17): 20.00", "Maximale Nachkommastelle (P18): Automatik" (dropdown), and "Einheit (P19): l" (dropdown). There is also a "Kundenspezifisch:" label with an empty input field.
- Datum:** Contains a "Messstellendatum:" label, a date input field showing "01.01.2008" with up/down arrows, and a "Heute" button.

At the bottom right of the dialog, there are two buttons: "OK" and "Abbrechen".

- P01 Measuring unit, e.g. mbar
- P04 Attenuation: 2.5
- P05 Measuring range lower range value: 62.8, see example calculation
- P06 Measuring range upper range value: 847.6, see example calculation
- P11 Characteristic line: linear
- P14 Temperature measuring unit (only for displaying or as HART® signal): °C
- P16 Scaling start: scaling on the tank, e.g. in liters: 0
- P17 Scaling end: scaling on the tank, e.g. in liters: 200
- P18 Maximum decimal place: automatic
- P19 Scaling unit: L (liters)



### NOTE!

No zero point adjustment should be performed after configuring the level measurement without a pressure specification (for  $\pm$  measuring range).

---

### 8.4.3 Without a diaphragm seal in closed containers with $\pm$ measuring ranges or 0 to 1 bar

The device is ideally suited for level measurements in open and containers.

#### With rotary knob operation (parameter level)

**Swap from display level to parameter level**, see chapter 7.3 "The level concept", Page 43

The following configuration steps should be taken:

- P1 Unit, e. g. mbar
- P4 Attenuation: 0
- P5 Measuring range lower range value: 0
- P6 Measuring range upper range value: 2.00 (2 m water column in this example)
- P7 Zero point adjustment, set device to zero, e.g. if tank is empty
- P11 Characteristic line: linear
- P14 Temperature measuring unit (only for displaying or as HART® signal): °C
- P16 Scaling start: scaling on the tank, e.g. in liters: 0
- P17 Scaling end: scaling on the tank, e.g. in liters: 200
- P19 Scaling unit: L (liters)

**Swap from parameter level to display level**

# 8 Configuration

With JUMO setup program

## Data transfer from the device

Editing      Maintenance

The following dialog window opens:

The screenshot shows the 'Instandhaltung' dialog window with the following settings:

- Messbereich:**
  - Maßeinheit (P01): mH2O
  - Messanfang (P05): 0.000 mH2O
  - Messende (P06): 1.500 mH2O
  - Offset (P15): -0.210 mH2O
- Kennlinie:**
  - Dämpfung (P04): 2.5 sec
  - Kennlinie (P11): Linear
  - Einsatzpunkt (P12): 9.4 %
- Skalierung:**
  - Anfang (P16): 0.00
  - Ende (P17): 20.00
  - Maximale Nachkommastelle (P18): Automatik
  - Einheit (P19): l
  - Kundenspezifisch: (empty)
- Datum:**
  - Messstellendatum: 01.01.2008 (with 'Heute' button)

Buttons at the bottom: OK, Abbrechen

- P01      Measuring unit, e.g. mbar
- P04      Attenuation: 0
- P05      Measuring range lower range value: 0
- P06      Measuring range upper range value: 2.00 (2 m water column in this example)
- P11      Characteristic line: linear
- P14      Temperature measuring unit (only for displaying or as HART® signal): °C
- P16      Scaling start: scaling on the tank, e.g. in liters: 0
- P17      Scaling end: scaling on the tank, e.g. in liters: 200
- P18      Maximum decimal place: automatic
- P19      Scaling unit: L (liters)

After entering the desired values: Data transfer to device

**Zero point adjustment, set device to zero, e.g. if tank is empty**

**Extras      Extras: Online operation\_sensor zero point calibration**

## 8.4.4 For steam layering with $\pm$ measuring ranges

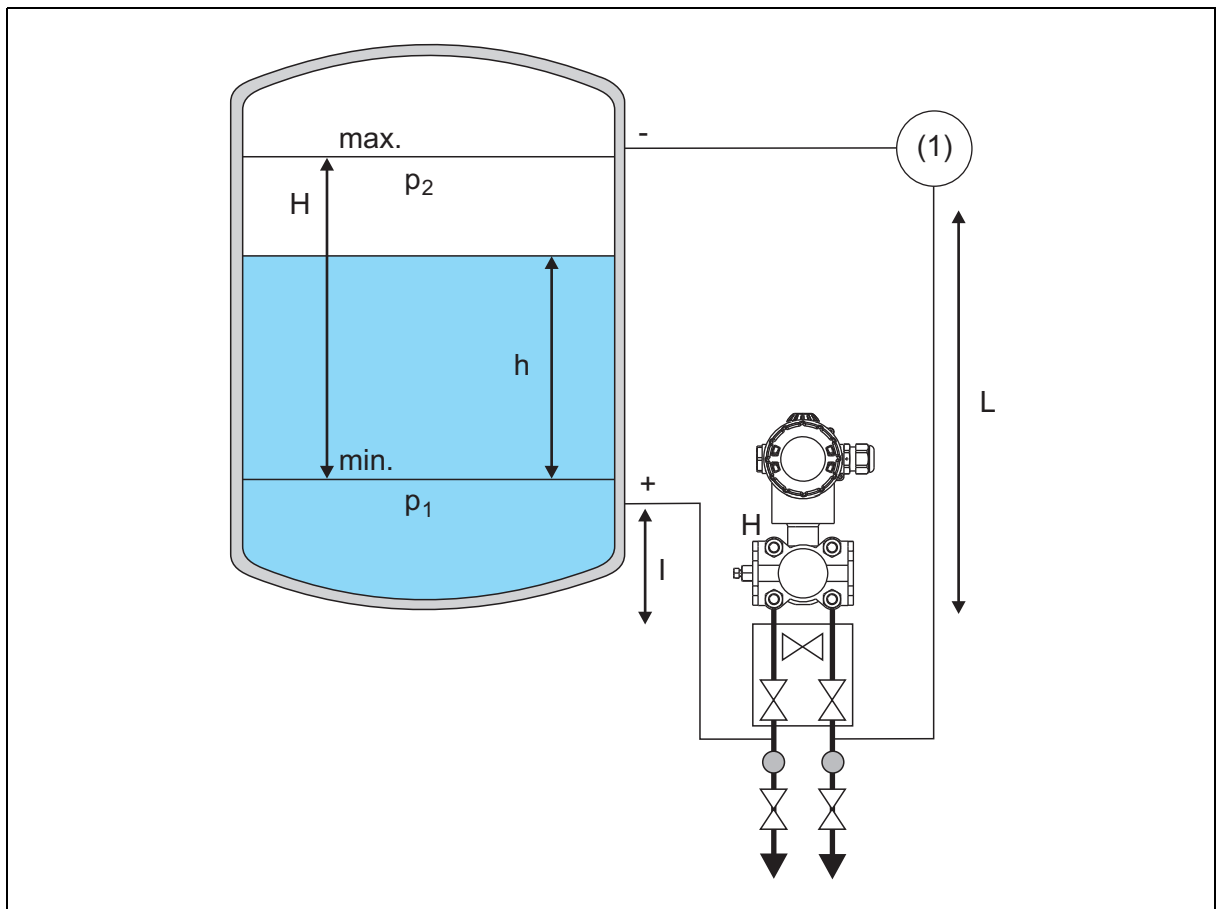

(1) Condensing vessel

I Vertical distance from tank to measuring device input

L Vertical distance from condensing vessel to measuring device input

### Range start (4 mA):

Measuring range lower range [mbar] =  $(L - I) \times \rho_{vap} \times g \times 0,01$   
value P5

### Range end (20 mA):

Measuring range upper range [mbar] =  $([L - I] + H) \times \rho_{vap} \times g \times 0,01$   
value P6

### Legend:

H	[mm]	=	Max. filling level height
h	[mm]	=	Max. level of the measured liquid, $0 < h \leq H$
L	[mm]	=	Vertical distance from tank to measuring device input (low pressure)
I	[mm]	=	Vertical distance from condensing vessel to measuring device input (high pressure)
$\rho_{vap}$	[g/cm <sup>3</sup> ]	=	1.00, density of the water, 4 °C
$\rho_{liq}$	[g/cm <sup>3</sup> ]	=	Density of the measured liquid
g	[m/s <sup>2</sup> ]	=	9.81, gravitational acceleration

## 8 Configuration

---

### Example:

Tank height		=	10 m
H	[mm]	=	7000
h	[mm]	=	6000
L	[mm]	=	8000
l	[mm]	=	100
Measuring range lower range value P5	[mbar]	=	$(8000 - 100) \times 1.00 \times 9.81 \times 0.01 = 77.50$
Measuring range upper range value P6	[mbar]	=	$[(8000 - 100) + 7000] \times 1.00 \times 9.81 \times 0.01 = 1461.69$

### With rotary knob operation (parameter level)

**Swap from display level to parameter level**, see chapter 7.3 "The level concept", Page 43

The following configuration steps should be taken:

P0	Density correction for $\rho_{\text{liq}}$ : Density of the liquid to be measured, water at 4 °C = density 1
P1	Unit, e. g. mbar
P4	Attenuation: 0
P5	Measuring range lower range value: 77.50, see example calculation
P6	Measuring range upper range value: 1461.69, see example calculation
P14	Temperature measuring unit (only for displaying or as HART® signal): °C
P16	Scaling start: scaling on the tank, e.g. in liters: 0
P17	Scaling end: scaling on the tank, e.g. in liters: 200
P19	Scaling unit: L (liters)

**Swap from parameter level to display level**



### CAUTION!

**No zero point adjustment may be performed for this configuration of the level measurement**

---

### With JUMO setup program

#### Data transfer from the device

Editing      Maintenance

The following dialog window opens:

# 8 Configuration

**Instandhaltung**

**Messbereich**

Maßeinheit (P01): mH2O

Messanfang (P05): 0.000 mH2O

Messende (P06): 1.500 mH2O

Offset (P15): -0.210 mH2O

**Kennlinie**

Dämpfung (P04): 2.5 sec

Kennlinie (P11): Linear

Einsatzpunkt (P12): 9.4 %

**Skalierung**

Anfang (P16): 0.00

Ende (P17): 20.00

Maximale Nachkommastelle (P18): Automatik

Einheit (P19): l

Kundenspezifisch:

**Datum**

Messstellendatum: 01.01.2008 Heute

OK Abbrechen

- P01 Measuring unit, e.g. mbar
- P04 Attenuation: 0
- P05 Measuring range lower range value: 77.50, see example calculation
- P06 Measuring range upper range value: 1461.69, see example calculation
- P11 Characteristic line: linear
- P14 Temperature measuring unit (only for displaying or as HART® signal): °C
- P16 Scaling start: scaling on the tank, e.g. in liters: 0
- P17 Scaling end: scaling on the tank, e.g. in liters: 200
- P18 Maximum decimal place: automatic
- P19 Scaling unit: L (liters)

After entering the desired values: Data transfer to device

**Zero point adjustment, set device to zero, e.g. if tank is empty**

**Extras Extras: Online operation\_sensor zero point calibration**

# 8 Configuration

## 8.4.5 For steam layering with a measuring range of 0 to 1 bar

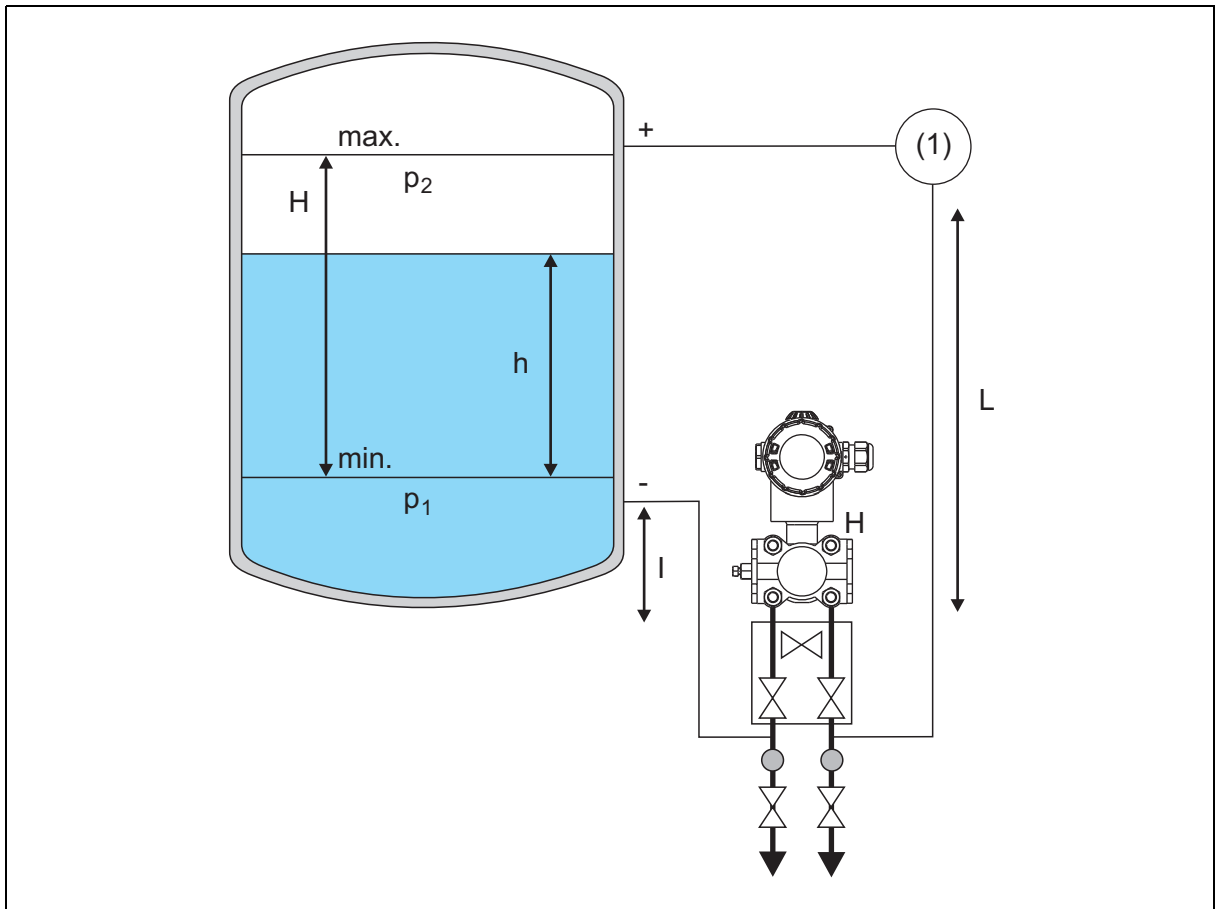

(1) Condensing vessel

l Vertical distance from tank to measuring device input

L Vertical distance from condensing vessel to measuring device input

### Range start (4 mA):

Measuring range lower range value P5 [mbar] =  $([L - l] + H) \times \rho_{vap} \times g \times 0,01$

### Range end (20 mA):

Measuring range upper range value P6 [mbar] =  $(L - l) \times \rho_{vap} \times g \times 0,01$

### Legend:

H	[mm]	=	Vertical distance of the diaphragm seal
h	[mm]	=	Max. level of the measured liquid, $0 < h \leq H$
L	[mm]	=	Vertical distance from tank to measuring device input (low pressure)
l	[mm]	=	Vertical distance from condensing vessel to measuring device input (high pressure)
$\rho_{vap}$	[g/cm <sup>3</sup> ]	=	1.00, density of the water, 4 °C
$\rho_{liq}$	[g/cm <sup>3</sup> ]	=	Density of the measured liquid
g	[m/s <sup>2</sup> ]	=	9.81, gravitational acceleration



**Example:**

Tank height		=	10 m
H	[mm]	=	7000
h	[mm]	=	6000
L	[mm]	=	8000
l	[mm]	=	100
Measuring range lower range value P5	[mbar]	=	$([8000 - 100] + 7000) \times 1.00 \times 9.81 \times 0.01 = 1461.69$
Measuring range upper range value P6	[mbar]	=	$(8000 - 100) \times 1.00 \times 9.81 \times 0.01 = 77.50$

**With rotary knob operation (parameter level)**

**Swap from display level to parameter level**, see chapter 7.3 "The level concept", Page 43

The following configuration steps should be taken:

P0	Density correction for $\rho_{\text{liq}}$ : Density of the liquid to be measured, water at 4 °C = density 1
P1	Unit, e. g. mbar
P4	Attenuation: 0
P5	Measuring range lower range value: 1461.69, see example calculation
P6	Measuring range upper range value: 77.50, see example calculation
P14	Temperature measuring unit (only for displaying or as HART® signal): °C
P16	Scaling start: scaling on the tank, e.g. in liters: 0
P17	Scaling end: scaling on the tank, e.g. in liters: 200
P19	Scaling unit: L (liters)

**Swap from parameter level to display level****With JUMO setup program****Data transfer from the device**

Editing Maintenance

The following dialog window opens:

# 8 Configuration

**Instandhaltung**

**Messbereich**

Maßeinheit (P01): mH2O

Messanfang (P05): 0.000 mH2O

Messende (P06): 1.500 mH2O

Offset (P15): -0.210 mH2O

**Kennlinie**

Dämpfung (P04): 2.5 sec

Kennlinie (P11): Linear

Einsatzpunkt (P12): 9.4 %

**Skalierung**

Anfang (P16): 0.00

Ende (P17): 20.00

Maximale Nachkommastelle (P18): Automatik

Einheit (P19): l

Kundenspezifisch:

**Datum**

Messstellendatum: 01.01.2008 Heute

OK Abbrechen

- P01 Measuring unit, e.g. mbar
- P04 Attenuation: 0
- P05 Measuring range lower range value: 1461.69, see example calculation
- P06 Measuring range upper range value: 77.50, see example calculation
- P11 Characteristic line: linear
- P14 Temperature measuring unit (only for displaying or as HART® signal): °C
- P16 Scaling start: scaling on the tank, e.g. in liters: 0
- P17 Scaling end: scaling on the tank, e.g. in liters: 200
- P18 Maximum decimal place: automatic
- P19 Scaling unit: L (liters)

After entering the desired values: Data transfer to device

**Zero point adjustment, set device to zero, e.g. if tank is empty**

**Extras Extras: Online operation\_sensor zero point calibration**



## CAUTION!









**No zero point adjustment may be performed for this configuration of the level measurement**

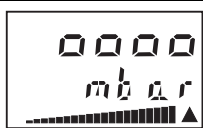

## NOTE!

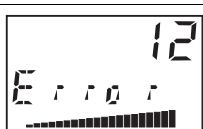
If you notice an external fault (including a mechanical one), the device must be sent to the manufacturer to be repaired.

## 9.1 Overcoming errors and malfunctions

Error/fault		Possible cause	Remedy
Display:	None	No voltage supply	Turn on the voltage supply
		Device faulty	Send the device to the supplier for repairs.
Display:		Overrange, overpressure	Bring the pressure back into the measuring range or adjust the measuring range.
Display:		Underrange, underpressure	
Display:		Pressure can no longer be displayed, overpressure	Adjust scaling or unit of measure
Display:		Pressure can no longer be displayed, underpressure	
Display:		The connection between sensor and electronic is broken.	a) Proof the plug connection at the back of the electronic module b) Send the device to the supplier for repairs.
Display:		An error was discovered in the electronics during the self test.	Send the device to the supplier for repairs.
Display:		Temperature sensor or pressure sensor faulty	Send the device to the supplier for repairs.
The rotary knob is not responding		Keyboard lock	Override keyboard lock
		Device faulty	Send the device to the supplier for repairs.

## 9 Maintenance

---

# 10 HART® 7 specification

The device is in the version with HART® protocol if it has a corresponding identification marking on the nameplate: 4 to 20 mA HART®

## 10.1 Device identification

Manufacturer	JUMO GmbH & Co. KG
Manufacturer ID	24716 (0x608C)
Device type	JUMO dTRANS p20
Device ID	58062 (0xE2CE)
HART® Protocol Version	7
Device version	1
Number of device variables	3
Physical layers supported	FSK
Device category	Transmitter, without galvanic isolation

## 10.2 Variable codes

The process pressure transmitter supports three device variables and two dynamic device variables as well as the fixed measurands percentage value and milliampere value.

The following table describes the variable numbering that is required for commands 9, 54, and 107.

Variable code	Designation	Class	Unit
0	Customer scaled value	Depending on the current P19 unit: 0 = not classified 66 = flow 68 = level	Depending on the current P19 unit: 57, 73, 74, 75, 77, 78, 24, 17, 138, 28, 131, 19, 41, 43, 253 = diverse flow and level units
1	Drag indicator minimum	65 = pressure	Depending on the current P1 unit: 1, 2, 3, 4, 5, 6, 7, 8, 10, 12, 13, 237, 240 = diverse pressure units
2	Drag indicator maximum	65 = pressure	Depending on the current P1 unit: 1, 2, 3, 4, 5, 6, 7, 8, 10, 12, 13, 237, 240 = diverse pressure units
244	Percent	0 = not classified	57 = percent
245	Current	84 = current	39 = mA
246	Primary variable	65 = pressure	Depending on the current P1 unit: 1, 2, 3, 4, 5, 6, 7, 8, 10, 12, 13, 237, 240 = diverse pressure units
247	Secondary variable	64 = temperature	Depending on the current P14 unit: 32 = level C 33 = level F

# 10 HART® 7 specification

## 10.3 HART® commands

Command	Designation	Request data	Response data (plus 2 status bytes)
<b>Universal commands (0 to 30 as well as 38 and 48)</b>			
0	Read unique identifier	None	22 bytes includes the long address
1	Read Primary Variable	None	1 byte unit code P 4 bytes pressure P as float
2	Read current and percent	None	4 bytes current as float 4 bytes percent as float
3	Read current and dynamic variables	None	4 bytes current as float 1 byte unit code P 4 bytes pressure P as float 1 byte unit code T 4 bytes temp T as float
6	Write polling address	1 byte short address 1 byte LoopCurr_active	As request
7	Read loop configuration	None	1 byte short address 1 byte LoopCurr_active
8	Read dynamic variable classifications	None	1 Byte Class PrimV 1 Byte Class SecV 1 Byte Class ThirdV 1 Byte Class QuadV
9	Read device variables with status	1 byte DevVarCode [1 byte DevVarCode] [1 byte DevVarCode] [1 byte DevVarCode]	1 byte ExtendedDevStatus 8 bytes info about DevVar [8 bytes info about DevVar] [8 bytes info about DevVar] [8 bytes info about DevVar] 4 bytes TimeStamp
11	Read unique identifier by TAG	6 bytes TAG no.	Same as command 0
12	Read message	None	24 bytes message
13	Read TAG + descriptor + date	None	6 bytes TAG no.  12 bytes description 3 bytes date
14	Read PV sensor info	None	3 bytes sensor man.no. 1 byte unit code sensor 4 bytes SensorMax as float 4 bytes SensorMin as float 4 bytes SensorSpan as float

# 10 HART® 7 specification

Command	Designation	Request data	Response data (plus 2 status bytes7)
15	Read device info	None	1 byte alarm code 1 byte "P11 Chr" 1 byte unit code sensor 4 bytes "P6 RE" (range end) 4 bytes "P5 RS" (range start) 4 bytes "P4 sec" 1 byte code write lock 1 byte manufacturer code 1 byte AnalogChannelFlag
16	Read final assembly number	None	3 bytes assembly number
17	Write message	24 bytes message	As request
18	Write TAG + descriptor + date	6 bytes TAG no.  12 bytes description 3 bytes calibration date	As request
19	Write final assembly number	3 bytes assembly number	As request
20	Read long TAG	None	32 bytes long TAG
21	Read unique identifier by Long TAG	32 bytes long TAG	Same as command 0
22	Write long TAG	32 bytes long TAG	As request
<b>Common Practice Commands (32 to 121, except 38 and 48)</b>			
34	Write damping value	4 bytes "P4 sec"	As request
35	Write range values	1 byte unit code 4 bytes "P6 RE" 4 bytes "P5 RS"	As request
36	Set upper range value	None	None
37	Set lower range value	None	None
38	Reset configuration changed flag	2 bytes ConfigChCnt	2 bytes ConfigChCnt
40	Fixed current mode	4 bytes "P8 mA" (0 = Current generator mode off)	As request
41	Perform self test	None	None
42	Perform device reset	None	None
43	Set PV zero ("P7 Zero") Absent with absolute pressure sensors!	None	None
44	Write PV units	1 byte "P1 Uni"	As request
45	Trim loop current zero	4 bytes measured mA as float	As request
46	Trim loop current gain	4 bytes measured mA as float	As request

# 10 HART® 7 specification

Command	Designation	Request data	Response data (plus 2 status bytes7)
48	Read additional device status	None	6 bytes dev specific status  1 byte extended dev status 1 byte dev operating mode 1 byte standardized status
54	Read device variable info	1 byte DevVarCode	27 bytes info about DevVar
59	Write number of response preambles	1 byte number of preambles	As request
103	Write burst period	1 byte BurstMsgNr 4 bytes BurstMinUpdTime 4 bytes BurstMaxUpdTime	As approved request; invalid values are automatically set to the nearest valid value
104	Write burst trigger	1 byte BurstMsgNr 1 byte BurstTrigMode 1 byte BurstTrigClass 1 byte BurstTrigUnits 4 bytes BurstTrigValue	As request
105	Read burst mode configuration	[1 byte BurstMsgNo]	1 byte BurstAktiv  1 byte BurstCmd 8 bytes BurstDevVarCode 1 byte BurstMsgNr 1 byte number BurstCfg 2 bytes BurstCmd16Bit 4 bytes BurstMinUpdTime 4 bytes BurstMaxUpdTime 1 byte BurstTrigMode 1 byte BurstTrigClass 1 byte BurstTrigUnits 4 bytes BurstTrigValue
107	Write burst device variables	1 byte DevVarCode  [1 byte DevVarCode] [1 byte DevVarCode] [1 byte DevVarCode] [1 byte DevVarCode] [1 byte DevVarCode] [1 byte DevVarCode] [1 byte DevVarCode] [1 byte BurstMsgNo]	8 bytes BurstDevVarCode  1 byte BurstMsgNr
108	Write burst mode command number	2 bytes BurstCmd16Bit 1 byte BurstMsgNr	As request
109	Burst Mode Control	1 byte Burst_Active [1 byte BurstMsgNo]	As request



Command	Designation	Request data	Response data (plus 2 status bytes7)
<b>Device-specific commands (128 to 253)</b>			
128	Write offset	1 byte unit code 4 bytes "P15 OFF"	As request
129	Read offset	None	1 byte "P1 Uni" 4 bytes "P15 OFF"
130	Reset min/max value	1 byte both/min/max	As request
131	Read min/max value	None	4 bytes DragIndicatorMax 4 bytes DragIndicatorMin In "P1 Uni"
132	Write output mode	1 byte "P11 Chr"	As request
133	Read output mode	None	1 byte "P11 Chr"
134	Write error mode	1 byte "P9 Err"	As request
135	Read error mode	None	1 byte "P9 Err"
136	Write keyboard mode	1 byte "P10 Key"	As request
137	Read keyboard mode	None	1 byte "P10 Key"
138	Write temperature unit	1 byte "P14 Uni"	As request
141	Read square root start	None	4 bytes "P12 %"
142	Write square root start	4 bytes "P12 %"	As request
147	Write Scale_Beg + Scale_End	4 bytes "P17 SCE"  4 bytes "P16 SCS"	As request
148	Read Scale_Beg + Scale_End	None	4 bytes "P17 SCE"  4 bytes "P16 SCS"
149	Write Scale_Unit	1 byte unit code for "P19 %"	As request
151	Write Scale_Comma	1 byte "P18 SCD" [Auto/0/1/2/3]	As request
152	Read Scale_Comma	None	1 byte "P18 SCD" [Auto/0/1/2/3]

## 10.4 Burst mode commands

The burst mode is an operating mode in which the device sends telegrams independently without an inquiry. It is configured with the setup program or with the commands 103 to 109.

The following commands are available:

Command	Designation
1	Primary variable
2	Current and percent
3	Current and dynamic variables
9	Device variables
48	Additional device status

# 10 HART® 7 specification

---

## 10.5 Performance data

The parameters that are listed below determine the performance of the process pressure transmitter.

### Telegram length

The maximum telegram length of up to 68 bytes occurs with this HART® 7 device with command 9 (39 bytes payload including 2 status bytes).

### Operating modes

The process pressure transmitter has three output operating modes:

- Standard mode (single mode): current proportional to measurand
- Current generator mode: current is adjusted through HART® command 40 or through adjustment parameter "P8 mA"
- Constant current mode (multidrop mode): current is set to constant 4 mA in bus operation (HART® command 6)

### Write protection

The device can be protected against unintentional overwriting of a parameter through a keyboard lock.

- At the device through parameter "P10 key"
- In the setup program under "Further maintenance data - Inhibit (P10)"
- Via HART® command 136 and 137

**JUMO GmbH & Co. KG**

Moritz-Juchheim-Straße 1  
36039 Fulda, Germany

Tel.: +49 661 6003-0  
Fax: +49 661 6003-500

E-Mail: mail@jumo.net  
Internet: www.jumo.net



More than **sensors + automation**

## EU-Konformitätserklärung

EU declaration of conformity / Déclaration UE de conformité

<b>Dokument-Nr.</b> <i>Document No. / Document n°.</i>	CE 602	
<b>Hersteller</b> <i>Manufacturer / Etabli par</i>	JUMO GmbH & Co. KG	
<b>Anschrift</b> <i>Address / Adresse</i>	Moritz-Juchheim-Straße 1, 36039 Fulda, Germany	
<b>Produkt</b> <i>Product / Produit</i>		
<b>Name</b> <i>Name / Nom</i>	<b>Typ</b> <i>Type / Type</i>	<b>Typenblatt-Nr.</b> <i>Data sheet no. / N° Document d'identification</i>
dTRANS p20 DELTA Ex d	403023	403023

**Wir erklären in alleiniger Verantwortung, dass das bezeichnete Produkt die Anforderungen der Europäischen Richtlinien erfüllt.**

*We hereby declare in sole responsibility that the designated product fulfills the requirements of the European Directives.  
Nous déclarons sous notre seule responsabilité que le produit remplit les Directives Européennes.*

**Richtlinie 1**

*Directive / Directive*

**Name** EMC  
*Name / Nom*

**Fundstelle** 2014/30/EU  
*Reference / Référence*

**Bemerkung**  
*Comment / Remarque*

**Datum der Erstanbringung des CE-Zeichens** 2011

**auf dem Produkt**

*Date of first application of the CE mark to the product / Date  
de 1ère application du sigle sur le produit*

Dokument-Nr.  
Document No. / Document n°.

CE 602

EU-Konformitätserklärung

Seite: 1 von 4

# 11 Declaration of conformity

## JUMO GmbH & Co. KG

Moritz-Juchheim-Straße 1  
36039 Fulda, Germany

Tel.: +49 661 6003-0  
Fax: +49 661 6003-500

E-Mail: mail@jumo.net  
Internet: www.jumo.net



More than **sensors + automation**

### Angewendete Normen/Spezifikationen

*Standards/Specifications applied / Normes/Spécifications appliquées*

#### Fundstelle

*Reference / Référence*

#### Ausgabe

*Edition / Édition*

#### Bemerkung

*Comment / Remarque*

EN 61326-1

2013

EN 61326-2-3

2013

### Gültig für Typ

*Valid for Type / Valable pour le type*

403023/...

### Richtlinie 2

*Directive / Directive*

#### Name

*Name / Nom*

ATEX

#### Fundstelle

*Reference / Référence*

2014/34/EU

#### Bemerkung

*Comment / Remarque*

Mod. B+D

**Datum der Erstanbringung des CE-Zeichens** 2011

#### auf dem Produkt

*Date of first application of the CE mark to the product / Date de 1ère application du sigle sur le produit*

### Angewendete Normen/Spezifikationen

*Standards/Specifications applied / Normes/Spécifications appliquées*

#### Fundstelle

*Reference / Référence*

#### Ausgabe

*Edition / Édition*

#### Bemerkung

*Comment / Remarque*

EN 60079-0

2012+A11:2013

EN 60079-1

2014

EN 60079-26

2015

EN 60079-31

2014

### Gültig für Typ

*Valid for Type / Valable pour le type*

403023/...

Dokument-Nr.  
Document No. / Document n°.

CE 602

EU-Konformitätserklärung

Seite: 2 von 4

# 11 Declaration of conformity

## JUMO GmbH & Co. KG

Moritz-Juchheim-Straße 1  
36039 Fulda, Germany

Tel.: +49 661 6003-0  
Fax: +49 661 6003-500

E-Mail: mail@jumo.net  
Internet: www.jumo.net



More than **sensors + automation**

## EU-Baumusterprüfbescheinigung 2.1

*EU type examination certificate / Certificat d'examen de type UE*

### Fundstelle

*Reference / Référence*

SEV 10 ATEX 0127 X

### Benannte Stelle

*Notified Body / Organisme notifié*

Eurofins Electrosuisse Product Testing AG

### Kennnummer

*Identification no. / N° d'identification*

1258

## Gültig für Typ

*Valid for Type / Valable pour le type*

403023/...

## Anerkannte Qualitätssicherungssysteme der Produktion

*Recognized quality assurance systems of production / Systèmes de qualité reconnus de production*

### Benannte Stelle

*Notified Body / Organisme notifié*

TÜV NORD CERT GmbH

### Kennnummer

*Identification no. / N° d'identification*

0044

## Richtlinie 3

*Directive / Directive*

### Name

*Name / Nom*

RoHS

### Fundstelle

*Reference / Référence*

2011/65/EU

### Bemerkung

*Comment / Remarque*

**Datum der Erstanbringung des CE-Zeichens** 2017

### auf dem Produkt

*Date of first application of the CE mark to the product / Date*

*de 1ère application du sigle sur le produit*

Dokument-Nr.  
Document No. / Document n°.

CE 602

EU-Konformitätserklärung

Seite: 3 von 4

# 11 Declaration of conformity

## JUMO GmbH & Co. KG

Moritz-Juchheim-Straße 1  
36039 Fulda, Germany

Tel.: +49 661 6003-0  
Fax: +49 661 6003-500

E-Mail: mail@jumo.net  
Internet: www.jumo.net



More than **sensors + automation**

### Angewendete Normen/Spezifikationen

*Standards/Specifications applied / Normes/Spécifications appliquées*

#### Fundstelle

*Reference / Référence*

#### Ausgabe

*Edition / Édition*

#### Bemerkung

*Comment / Remarque*

VDK Umweltrelevante Aspekte V1  
bei der Produktentwicklung und  
-gestaltung

### Gültig für Typ

*Valid for Type / Valable pour le type*

403023/...

### Aussteller

*Issued by / Etabli par*

JUMO GmbH & Co. KG

### Ort, Datum

*Place, date / Lieu, date*

Fulda, 2018-01-03

### Rechtsverbindliche Unterschrift

*Legally binding signature / Signature juridiquement valable*

Bereichsleiter Verkauf  
ppa. Wolfgang Vogl

Dokument-Nr.  
Document No. / Document n°.

CE 602

EU-Konformitätserklärung

Seite: 4 von 4



Electrosuisse  
Product Testing



## EU-Type Examination Certificate

- (1)
- (2) Equipment or protective system intended for use in potentially explosive atmospheres - **Directive 2014/34/EU**
- (3) Certificate number: **SEV 10 ATEX 0127 X**
- (4) Product: Process pressure transmitter  
JUMO dTRANS p20 type 403026  
JUMO dTRANS p20 DELTA type 403023
- (5) Manufacturer: JUMO GmbH & Co. KG
- (6) Address: Moritz-Juchheim-Strasse 1, 36039 Fulda, GERMANY
- (7) The equipment and any acceptable variation thereto is specified in the schedule to this certificate and the documents therein referred to.
- (8) Eurofins Electrosuisse Product Testing AG, notified body No. 1258, in accordance with article 17 of Directive 2014/34/EU of the European parliament and of the council, dated 26 February 2014, certifies that this product has been found to comply with the essential health and safety requirements relating to the design and construction of products intended for use in potentially explosive atmospheres given in Annex II to the Directive.  
The examination and test results are recorded in confidential report no 09-IK-0103.02 incl. extension 1 to 3
- (9) Compliance with the essential health and safety requirements has been assured by compliance with:  
**EN 60079-0:12 + A11:13    EN 60079-1:14    EN 60079-26:15**  
**EN 60079-31:14**  
Except in respect of those requirements listed at item 18 of the schedule.
- (10) If the sign «X» is placed after the certificate number, it indicates that the product is subjected to special conditions for safe use specified in the schedule to this certificate
- (11) This EU type examination certificate relates only to design and construction of the specified product. Further requirements of this directive apply to the manufacturing process and supply of this product. These are not covered by this certificate.
- (12) The marking of the product shall include the following:  
**See Appendix page 3: (20) Marking**

Eurofins Electrosuisse Product Testing AG  
ATEX Notified Body 1258

Martin Plüss  
Product Certification



# 12 Examination certificate

(13) **Appendix**

(14) **EU-Type Examination Certificate no. SEV 10 ATEX 0127 X**

(15) **Description of product**

The process pressure transmitter JUMO dTRANS p20 type 403026 or JUMO dTRANS p20 DELTA type 403023 serves for converting a physical measured quantity (pressure) into a standard electrical signal (current signal 4...20 mA). They are intended for use in potentially explosive atmospheres. The precision cast stainless steel enclosure of the pressure trans-mitter is dust-tight with the minimum type of protection IP 66 according to IEC 60529.

**Ratings**

Supply circuit U = 12.0 VDC up to 36.0 VDC  
I = 22mA

Classification of installation and use: stationary  
Ingress protection: IP66

Rated ambient temperature range: Assignment between the maximum permissible ambient temperature in the electronic enclosure, measuring temperature and the maximum surface temperature for the process pressure transmitter is shown in the following values:

**JUMO dTRANS p20 Typ 403026:**

Ambient temperature:  
T6: -50 °C ... +60 °C  
T5: -50 °C ... +70 °C  
T4: -50 °C ... +85 °C  
T105: -50 °C ... +85 °C

**Maximum permissible measuring substance temperature:**

T6: +70 °C  
T5: +85 °C  
T4: +115 °C  
T105: +100 °C

**JUMO dTRANS p20 Typ 403023:**

Ambient temperature:  
T6: -50 °C ... +60 °C  
T5: -50 °C ... +70 °C  
T4: -50 °C ... +85 °C  
T105: -50 °C ... +85 °C

**Maximum permissible measuring substance temperature:**

T6: +70 °C  
T5: +85 °C  
T4: +110 °C  
T105: +100 °C





(16) **Report number** 09-IK-0103.02 incl. extension 1 to 3

(17) **Specific conditions of use**

- In the temperature range of -40 °C ... -50 °C the lid with inspection glass of the appliance has to be additionally protected against mechanical impact- respectively collision effect.
- Where temperatures higher than +70 °C occur at the cable entry or +80 °C at the junction of the conductors, only a tested and heat-resistant cable must be connected.
- Only separately certified cable glands and blanking elements according to Directive 2014/34/EU may be used.  
Unused openings shall be closed with the aforementioned blanking elements.

(18) **Essential health and safety requirements**

In addition to the essential health and safety requirements (EHSRs) covered by the standards listed at item 9, the following are considered relevant to this product, and conformity is demonstrated in the report:

Clause	Subject
None	

(19) **Drawings and Documents**

See test report "Manufacturer's Documents"

(20) **Marking**

JUMO dTRANS p20 type 403026		II 1/2G II 2D	Ex d IIC Ex tb IIIC	T6 ... T4 Ga/Gb T105 °C Db
JUMO dTRANS p20 DELTA Typ 403023		II 1/2G II 2D	Ex d IIC Ex tb IIIC	T6 ... T4 Ga/Gb T105 °C Db

## 12 Examination certificate

---

 有毒有害物质或元素 Hazardous substances		Hazardous substances						
		铅 (Pb)	汞 (Hg)	镉 (Cd)	六价铬 (Cr(VI))	多溴联苯 (PBB)	多溴二苯醚 (PBDE)	
部件名称 Product group: 403023								
外壳 Housing (Gehäuse)	○	○	○	○	○	○	○	
过程连接 Process connection (Prozessanschluss)	X	○	○	○	○	○	○	
螺母 Nut (Mutter)	○	○	○	○	○	○	○	
螺钉 Screw (Schraube)	○	○	○	○	○	○	○	

本表格依据 SJ/T 11364-2014 的规定编制。  
 (This table is prepared in accordance with the provisions of SJ/T 11364-2014.)  
 O : 表示该有害物质在该部件所有均质材料中的含量均在 GB/T 26572 规定的限量要求以下。  
 (O: Indicates that said hazardous substance contained in all of the homogeneous materials for this part is below the limit requirement of GB/T 26572.)  
 X : 表示该有害物质至少在该部件的某一均质材料中的含量超出 GB/T 26572 规定的限量要求。  
 (X: Indicates that said hazardous substance contained in one of the homogeneous materials used for this part is above the limit requirement of GB/T 26572.)







**JUMO GmbH & Co. KG**

Street address:  
Moritz-Juchheim-Straße 1  
36039 Fulda, Germany

Delivery address:  
Mackenrodtstraße 14  
36039 Fulda, Germany

Postal address:  
36035 Fulda, Germany

Phone: +49 661 6003-0  
Fax: +49 661 6003-607  
Email: [mail@jumo.net](mailto:mail@jumo.net)  
Internet: [www.jumo.net](http://www.jumo.net)

**JUMO Instrument Co. Ltd.**

JUMO House  
Temple Bank, Riverway  
Harlow, Essex, CM20 2DY, UK

Phone: +44 1279 63 55 33  
Fax: +44 1279 62 50 29  
Email: [sales@jumo.co.uk](mailto:sales@jumo.co.uk)  
Internet: [www.jumo.co.uk](http://www.jumo.co.uk)

**JUMO Process Control, Inc.**

6724 Joy Road  
East Syracuse, NY 13057, USA

Phone: +1 315 437 5866  
Fax: +1 315 437 5860  
Email: [info.us@jumo.net](mailto:info.us@jumo.net)  
Internet: [www.jumousa.com](http://www.jumousa.com)

