

JUMO TAROS S46 H

Pressure Transmitter



Operating Manual



40207100T90Z001K000

V2.01/EN/00705001/2021-10-14

1	Safety information	4
2	Introduction	6
2.1	Intended use	6
2.2	Block diagram	6
3	Identifying the device version	7
3.1	Nameplate	7
3.2	Order details	8
3.3	Accessories	10
4	Mounting	11
4.1	General information	11
4.2	Dimensions	12
4.2.1	Transmitter with electrical connections	12
4.2.2	Process connections	13
4.3	Important information for usage according to EHEDG	14
5	Electrical connection	15
5.1	Installation notes	15
5.2	Connection diagram	15
6	Operation	16
6.1	Zero point adjustment	16
7	Maintenance, cleaning and returns	17
7.1	Maintenance	17
7.2	Manual cleaning for maintenance or storage	17
7.3	Returns	17
8	Technical data	18
8.1	Mechanical features	18
8.2	Measuring range and accuracy	18
8.3	Electrical data	20
8.4	Environmental influences	21
8.5	Approvals and approval marks	22
9	China RoHS	23

1 Safety information

General

This manual contains information that must be observed in the interest of your own safety and to avoid material damage. This information is supported by symbols which are used in this manual as indicated.

Please read this manual before starting up the device. Store this manual in a place that is accessible to all users at all times.

If difficulties occur during startup, please do not intervene in any way that could jeopardize your warranty rights!

Warning symbols



DANGER!

This symbol indicates that **personal injury from electrocution** may occur if the appropriate precautionary measures are not taken.



WARNING!

This symbol in connection with the signal word indicates that **personal injury** may occur if the respective precautionary measures are not carried out.



CAUTION!

This symbol in connection with the signal word indicates that **material damage or data loss** will occur if the respective precautionary measures are not taken.



CAUTION!

This symbol indicates that **components could be destroyed** by electrostatic discharge (ESD = Electro Static Discharge) if the respective cautionary measures are not taken.

Only use the ESD packages intended for this purpose to return device inserts, assembly groups, or assembly components.



READ THE DOCUMENTATION!

This symbol, which is attached to the device, indicates that the associated **documentation for the device** must be **observed**. This is necessary to identify the nature of the potential hazard, and to take measures to prevent it.

Note symbols



NOTE!

This symbol refers to **important information** about the product, its handling, or additional benefits.



REFERENCE!

This symbol refers to **additional information** in other sections, chapters, or other manuals.



FURTHER INFORMATION!

This symbol is used in tables and indicates that **further information** is provided after the table.

1 Safety information



DISPOSAL!

At the end of its service life, the device and any batteries present do not belong in the trash! Please ensure that they are **disposed of** properly and in an **environmentally friendly** manner.

2 Introduction

2.1 Intended use

The pressure transmitter is used to acquire relative and absolute pressures in liquid and gaseous media. The JUMO TAROS S46 H with analog output signal has been developed specifically for hygienic applications. The pressure transmitter has a pressure measuring cell with a piezoresistive silicon sensor. The pressure is converted into an electrical current or voltage signal and output via various electrical connections.

A built-in magnetoresistive switch (MRS) enables the user to adjust the zero point of the device externally using a magnet.

The pressure transmitter is EAC-compliant and UL-approved¹. It is certified according to EHEDG in the versions with the process connections clamp, VARIVENT®, and JUMO PEKA.

The protection offered by the device may be impaired if the device is used in a way that does not comply with the manufacturer's intended use.

2.2 Block diagram

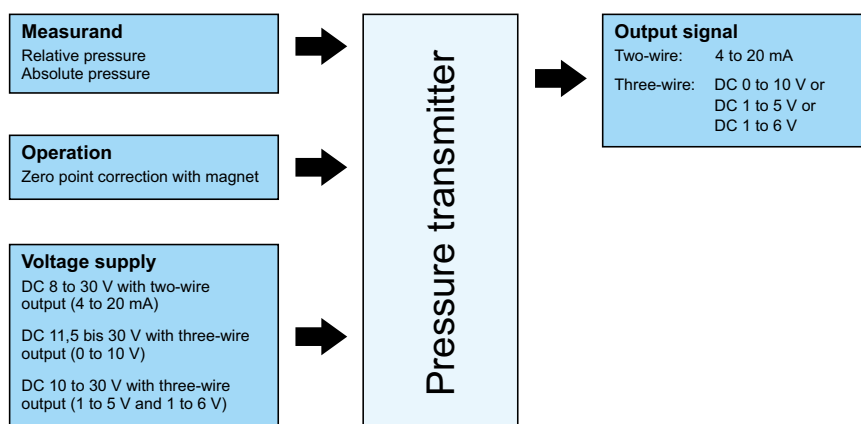

¹ The approval stipulates use of the transmitter indoors only. All surfaces are made from stainless steel in the versions with electrical **connection 36** (round plug M12 × 1) and electrical **connection 75** (terminal head). These versions of the transmitter are also suitable for outdoor use.

3 Identifying the device version

3.1 Nameplate

Position

The nameplate is laser-etched on the device surface.



Table of contents

The nameplate shows important information. This includes:

Description	Designation on the nameplate	Example
Device type	Typ	402071/000
Part no.	TN	00123456
Measuring range	0.. 0,1 bar rel.	0 to 0.1 bar relative pressure
Voltage supply	DC 8.. 30 V/25 mA	DC 8 to 30 V/25 mA
Output signal	4.. 20 mA	4 to 20 mA
Fabrication number	F-Nr.	0123456701020240123

Device type (Typ)

Compare the specifications on the nameplate with your order documents. The supplied device version can be identified using the order code (⇒ chapter 3.2 "Order details", Page 8).

Part no. (TN)

The part no. uniquely identifies an article in the catalog. It is important for communication between the customer and the sales department.

Fabrication number (F-Nr.)

Among other things, the fabrication number indicates the **production date** (year/week) and the hardware version number.

The **production date** is represented by digits 12 to 15 (from the left).

Example: F-No = 01234567010**2024**0123.

The device in this example was produced in the year **2020**, in the **24**th week.

3 Identifying the device version

3.2 Order details

	(1) Basic type
402071	JUMO TAROS S46 H – pressure transmitter
	(2) Basic type extension
000	None
045	Autoclave-compatible version ^{a, b}
051	Relative-pressure version without zero point adjustment
999	Special version
	(3) Input
478	-1 to 0 bar relative pressure
479	-1 to +0.6 bar relative pressure
449	-1 to +1 bar relative pressure
480	-1 to +1.5 bar relative pressure
481	-1 to +3 bar relative pressure
482	-1 to +5 bar relative pressure
483	-1 to +9 bar relative pressure
484	-1 to +15 bar relative pressure
485	-1 to +24 bar relative pressure
428	-0.4 to +0.4 bar relative pressure
427	-0.1 to +0.1 bar relative pressure
425	0 to 0.1 bar relative pressure
426	0 to 0.16 bar relative pressure
451	0 to 0.25 bar relative pressure
452	0 to 0.4 bar relative pressure
453	0 to 0.6 bar relative pressure
454	0 to 1 bar relative pressure
455	0 to 1.6 bar relative pressure
456	0 to 2.5 bar relative pressure
457	0 to 4 bar relative pressure
458	0 to 6 bar relative pressure
459	0 to 10 bar relative pressure
460	0 bar to 16 bar relative pressure
461	0 bar to 25 bar relative pressure
462	0 bar to 40 bar relative pressure
463	0 bar to 60 bar relative pressure
464	0 bar to 100 bar relative pressure
487	0 to 0.6 bar absolute pressure
488	0 to 1 bar absolute pressure
489	0 to 1.6 bar absolute pressure
490	0 to 2.5 bar absolute pressure
491	0 to 4 bar absolute pressure
500	0 to 5 bar absolute pressure
492	0 to 6 bar absolute pressure
493	0 to 10 bar absolute pressure
494	0 to 16 bar absolute pressure

3 Identifying the device version

495	0 to 25 bar absolute pressure
505	0 to 40 bar absolute pressure
998	Special measuring range for absolute pressure
999	Special measuring range for relative pressure
(4) Output	
405	4 to 20 mA, 2-wire
415	DC 0 to 10 V, three-wire
418	DC 1 to 5 V, three-wire
420	DC 1 to 6 V, three-wire
(5) Process connection	
604	Taper socket with union nut DN 25, DIN 11851 (dairy pipe fitting) ^c
607	Taper socket with union nut DN 50, DIN 11851 (dairy pipe fitting) ^d
613	Clamping socket (clamp) DN 25, 32, 40, DIN 32676 ^e
616	Clamping socket (clamp) DN 50, DIN 32676, 2" ISO 2852 ^e
652	Tank connection with grooved union nut DN 25 ^c
653	Tank connection with grooved union nut DN 40 ^c
685	VARIVENT® connection DN 32/25
686	VARIVENT® connection DN 50/40
997	JUMO PEKA hygienic process connection
(6) Process connection material	
53	Stainless steel 1.4404/1.4435
(7) Electrical connection	
12	Attached cable, shielded, length of 2 m
36	Round plug M12 × 1
61	Line socket DIN EN 175301-803, form A
75	Terminal head
(8) Measuring system, filling medium	
01	Silicone oil
(9) Extra codes	
000	None
061	With UL approval ^f
374	Inspection certificate 3.1 EN 10204 – material
452	Parts wetted by medium electrolytically polished
462	Inverted output signal
624	Oil and grease free
870	Inspection certificate 3.1 EN 10204 – surface
871	Inspection certificate 3.1 EN 10204 – accuracy
872	Declaration of compliance with the order 2.1 EN 10204 – material
873	Declaration of compliance with the order 2.1 EN 10204 – surface
874	Declaration of compliance with the order 2.1 EN 10204 – accuracy
875	Declaration of compliance with the order 2.1 EN 10204 – data sheet

^a Only with round plug M12 × 1 (electrical connection 36).

^b If the devices work with relative pressure, the relative pressure is compensated using round plug M12 × 1. To ensure reliable pressure compensation, use a corresponding mating connector with pressure equalization hose in the cable (part no. 00512341). Alternatively, a pressure compensation adapter (part no. 00739821) can be used.

^c Only possible with measuring ranges up to 40 bar.

^d Only possible with measuring ranges up to 25 bar.

3 Identifying the device version

^e The maximum measuring range that can be used is based on the clamp's pressure stage.

^f Not possible with electrical connection 12 (attached cable).

	(1)		(2)		(3)		(4)		(5)		(6)		(7)		(8)		(9)
Order code		/		-		-		-		-		-		-		/	
Order example	402071	/	999	-	453	-	405	-	613	-	53	-	36	-	01	/	374,870

3.3 Accessories



NOTE!

The following accessories are **not** UL-approved.

Item	Part no.
Cable socket, 4-pole, M12 × 1, straight, with 5 m PVC cable, with PA pressure equalization hose	00512341
Line socket, 4-pole, M12 × 1, straight, with 2-m PVC cable, without pressure compensation	00404585
Line socket, 4-pole, M12 × 1, angled, with 2-m PVC cable, without pressure compensation	00409334
Magnetic pin for simple adjustment of zero point	00736330
End cap M12 × 1 (for autoclave-compatible version)	00736095
Pressure compensation adapter M12 × 1	00739821



NOTE!

When using a transmitter with UL approval, the user must make sure that the accessory he uses is also approved for a UL application (e.g. cable with UL approval AVLV2/8 and/or cable with UL approval CYJV/7 or CYJV/8 or PVVA/7 or PVVA2/8, in each case approved for ambient temperatures > 90 °C).

4.1 General information



NOTE!

Check that the device is compatible with the measurement medium ⇒ chapter 8.4 "Environmental influences", Page 21.

Mounting site

- Ensure that the device is fastened safely and with low vibrations
- Avoid direct sunlight
- Please note the admissible ambient temperatures at the installation position ⇒ chapter 8.4 "Environmental influences", Page 21

Installation position

The device can be installed in any position.

We recommend the "upright" installation position, as shown below:



4 Mounting

4.2 Dimensions

4.2.1 Transmitter with electrical connections

12
Attached cable, length of 2 m (standard)

PA	L (mm)
604, 607, 613, 616, 685, 686, 997	75
652, 653	50

36
Round plug M12 × 1

PA	L (mm)
604, 607, 613, 616, 685, 686, 997	73
652, 653	48

61
Line socket DIN EN 175301-803, form A

PA	L (mm)	M (mm)
604, 607, 613, 616, 685, 686, 997	96	85
652, 653	71	60

75
Terminal head

PA	L (mm)	M (mm)
604, 607, 613, 616, 685, 686, 997	106	86
652, 653	81	61

Cable fitting M16, seal area 5 to 11 mm

PA = process connection

4.2.2 Process connections

604

Taper socket with union nut DN 25

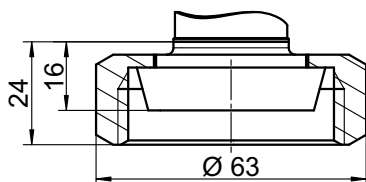

607

Taper socket with union nut DN 50

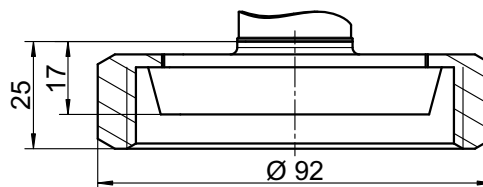

613

Clamping socket (clamp) DN 25, 32, 40

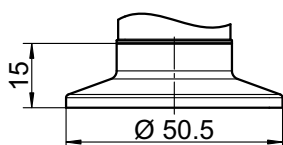

616

Clamping socket (clamp) DN 50

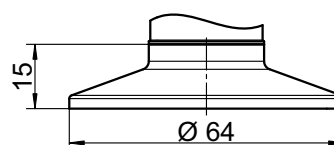

652

Tank connection with grooved union nut DN 25 (including welding socket)

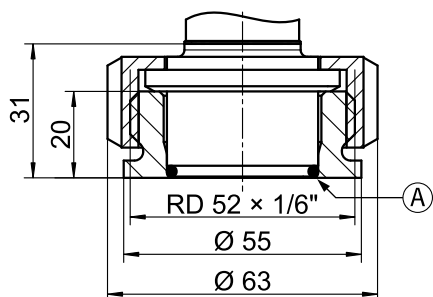

653

Tank connection with grooved union nut DN 40 (including welding socket)

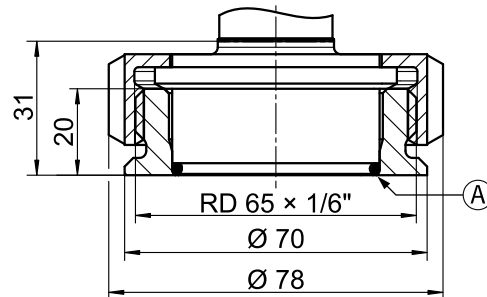

685

VARIVENT® connection DN 32/25

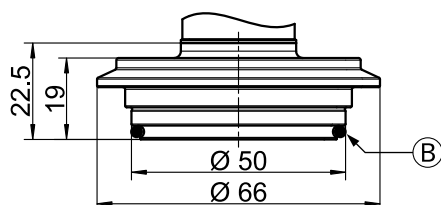

686

VARIVENT® connection DN 50/40

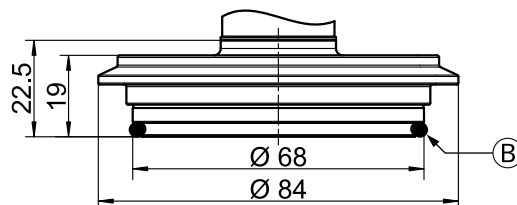

(A) Sealing ring, FPM

(B) Sealing ring, EPDM^a

^a EHEDG conformity according to "EHEDG Position Paper" is only ensured with EPDM.

4 Mounting

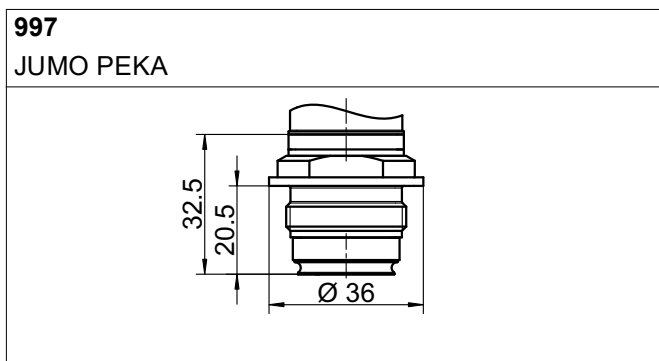

NOTE!

Detailed specifications on the JUMO PEKA process connection system can be found in data sheet 409711.

Other process connections upon request!

4.3 Important information for usage according to EHEDG

The following process connections are suitable for usage according to EHEDG:

- 613 and 616 (Clamp DN 25/32/40/50 with Tri-Clamp seals Combifit International B.V.)
- 685 and 686 (VARIVENT® connections DN 32/25 and DN 50/40 with EPDM O-ring)
- 997 (JUMO PEKA with FKM O-ring)

The pressure transmitter is suitable for CIP (Cleaning in Place) when installed accordingly. For details of the temperature resistance and material resistance, see chapter 8.4 "Environmental influences", Page 21.

Observe the following points to ensure EHEDG compliant integration in the respective plants:

- Where possible, provide a cavity-free installation.
- Install the connecting sockets so that they are self-draining.
- Use only EHEDG approved process connections according to the current EHEDG position paper.
- When used on tanks, the installation must be front-flush. Cleaning through direct spraying must be ensured. Cavities must be detectable.
- Install the leakage opening so that it is clearly visible. Install vertical lines facing downwards.

The following drawing shows an example installation. To avoid cavities, **L must be < D**.

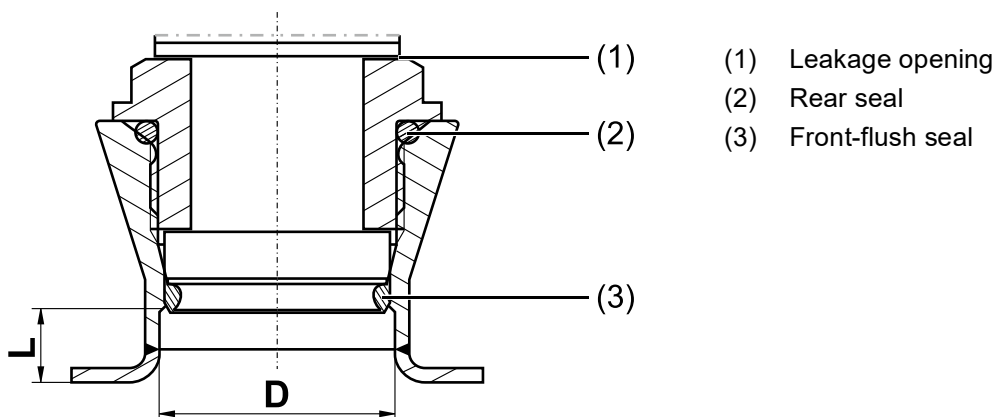

5 Electrical connection

5.1 Installation notes



NOTE!



The electrical connection must only be performed by qualified personnel.

The electromagnetic compatibility meets standard DIN EN 61326.

Do not connect any additional loads to the voltage supply of the device.

The device is not suitable for installation in potentially explosive areas.

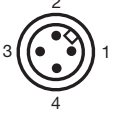
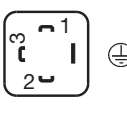
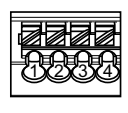
5.2 Connection diagram

Connection	Terminal assignment ^a				
					
	12 Attached cable	36 Round plug M12 × 1	61 Cable socket	75 Terminal head	
4 to 20 mA, 2-wire (output 405)					
Voltage supply DC 8 to 30 V	U _B /S+	White	1	1	1
	0 V/S-	Black	3	2	2
DC 0 to 10 V, 3-wire (output 415)					
Voltage supply DC 11.5 V to 30 V	U _B	White	1	1	1
	0 V/S-	Black	2	2	2
	S+	Yellow	3	3	3
DC 1 to 5 V, three-wire (output 418)					
DC 1 to 6 V, three-wire (output 420)					
Voltage supply DC 10 to 30 V	U _B	White	1	1	1
	0 V/S-	Black	2	2	2
	S+	Yellow	3	3	3
Functional bonding conductor FB ^b (all output variants)		Shield/green	4		4

^a Figure: Connection to the pressure transmitter

^b As a basic principle, the device is grounded via the process connection. Alternatively, the device can also be grounded via the electrical connection on all variants. However, grounding via both the process connection **and** the electrical connection is not admissible.

Admissible effect on the "attached cable" variant	
Smallest bending radius (fixed)	40 mm
Max. tensile force on the cable	20 N

6 Operation

6.1 Zero point adjustment

General Information

In the case of device versions designed for relative pressure, there is the option of a simple pressure/zero point adjustment (offset) using a magnet (remanence $B_R \geq 1$ T, e.g. NdFeB dia. 4×10 mm). This actuates a magnetoresistive switch inside the device when approaching it. A suitable magnet is available from JUMO as an accessory (part no. 00736330).

This provides a quick and simple way to correct zero point offsets caused by the installation or zero point offsets that have arisen following autoclaving, for example.

Requirements

The following conditions must be met in order to carry out a successful zero point adjustment:

- The adjustment must take place within a **timeframe of a maximum of 2 seconds** once the device is switched on.
- The pressure at the device at the point of the zero point adjustment must **not deviate more than ± 10 %** from the positive pressure measuring range of the device¹.

Procedure

1. Hold the magnet at the position of the QR code (1) on the nameplate of the device.
2. Switch on the voltage supply for the device.

The device recognizes the magnet (within the first 2 seconds) and automatically re-adjusts the zero point. As a result, the switch-on time is slightly delayed

3. Remove the magnet from the housing and keep it for further use.

The zero point adjustment is complete. The new zero point is permanently saved. However, you can carry out a further zero point adjustment at any time.

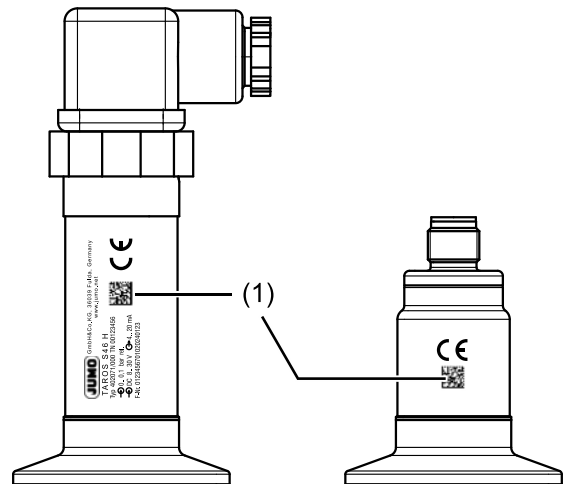

NOTE!

If the magnetic field is not applied within the timeframe of approx. 2 seconds after the device is switched on, it will not affect the zero point of the device.

A further zero point adjustment can only take place once the device has been switched off and switched back on again.

¹ Example 1: Measuring range 0 to 1 bar rel.; deviation from ambient pressure max. ± 0.1 bar.
Example 2: Measuring range -1 to +0.6 bar rel.; deviation from ambient pressure max. ± 0.1 bar.
Example 3: Measuring range -1 to 5 bar rel.; deviation from ambient pressure max. ± 0.5 bar.

7 Maintenance, cleaning and returns

7.1 Maintenance

The pressure transmitter is maintenance-free.

In the event of a malfunction, please return the device to the manufacturer together with accurate fault information.

7.2 Manual cleaning for maintenance or storage

The pressure transmitter – especially the parts in contact with the product – must not be damaged. Any damage to the stainless steel membrane must be avoided. The cleaning agent must not attack the surface and seals.

Note the protection type of the device.



WARNING!

Risk of burning due to hot surfaces

In the CIP/SIP cleaning process, the pressure transmitter's surfaces are subjected to hot temperatures of up to 140 °C. Contact with these surfaces could result in burns to the skin.

- ▶ When servicing the transmitter, check its surface temperature and, if necessary, wait until it has cooled.

7.3 Returns



NOTE!

In case of abnormalities, please send the device to the manufacturer together with a completed cover note for product returns. You can download a blank copy of this cover note online at:
<http://produktruecksendung.jumo.info>

8 Technical data

8.1 Mechanical features

Materials of parts coming into contact with the pressurized medium	
Membrane	Stainless steel 1.4435 (316 L)
O-ring/sealing ring	FPM, others available as an optional extra (e.g. EPDM, VMQ)
Process connection	Stainless steel 1.4404 (316 L)
Welding ring	Stainless steel 1.4404 (316 L)
Materials of other parts	
Housing	Stainless steel 1.4301 (304)
Cover cap M12 × 1 ^a	Stainless steel 1.4301 (304)
Electrical connection	
Attached cable	Cable fitting made from stainless steel 1.4301 (304); PUR cable with and without pressure compensation
Round plug M12 × 1	Threaded bushing made from stainless steel 1.4301 (304)
Cable socket	Holding ring/connector fastener made from high-quality plastic, comparable with PBT GF30 V0
Terminal head	Stainless steel 1.4301 (304); cable fitting: stainless steel
Rated position	Upright, with downward process connection
Operating position	Any, but there may be a zero offset relative to the rated position

^a Included on autoclave-compatible variant.

8.2 Measuring range and accuracy

Measuring range	Linearity ^a % MSP ^f	Accuracy at			Long-term stability ^b % MSP per year	Overload capability ^c bar	Burst pressure bar
		20 °C ^d % MSP	-20 to +80 °C ^e % MSP	-20 to +100 °C % MSP			
-1 to 0 bar relative pressure	0.15	0.3	1	1.2	≤ 0.15	10	20
-1 to +0.6 bar relative pressure	0.15	0.3	1	1.2	≤ 0.15	10	20
-1 bar to +1 bar relative pressure	0.15	0.3	1	1.2	≤ 0.15	10	20
-1 to +1.5 bar relative pressure	0.15	0.3	1	1.2	≤ 0.15	20	40
-1 to +3 bar relative pressure	0.1	0.25	0.75	0.8	≤ 0.1	25	50
-1 to +5 bar relative pressure	0.1	0.25	0.75	0.8	≤ 0.1	50	60
-1 to +9 bar relative pressure	0.1	0.25	0.75	0.8	≤ 0.1	50	60
-1 to +15 bar relative pressure	0.1	0.25	0.75	0.8	≤ 0.1	120	200
-1 to +24 bar relative pressure	0.1	0.25	0.75	0.8	≤ 0.1	120	200
-0.4 to +0.4 bar relative pressure	0.15	0.4	1	1.2	≤ 0.2	10	20
-0.1 to +0.1 bar relative pressure	0.2	0.5	1	1.2	≤ 0.2	6	10
0 to 0.1 bar relative pressure	0.25	0.75	1.2	---	≤ 0.2	1.5	3
0 to 0.16 bar relative pressure	0.25	0.75	1.2	1.5	≤ 0.2	6	10
0 to 0.25 bar relative pressure	0.25	0.5	1	1.2	≤ 0.2	6	10
0 to 0.4 bar relative pressure	0.15	0.4	1	1.2	≤ 0.15	10	20
0 to 0.6 bar relative pressure	0.15	0.4	1	1.2	≤ 0.15	10	20
0 to 1 bar relative pressure	0.15	0.3	1	1.2	≤ 0.15	10	20
0 to 1.6 bar relative pressure	0.15	0.3	1	1.2	≤ 0.15	20	40

8 Technical data

Measuring range	Linearity ^a % MSP ^f	Accuracy at			Long-term stability ^b % MSP per year	Overload capability ^c bar	Burst pressure bar
		20 °C ^d % MSP	-20 to +80 °C ^e % MSP	-20 to +100 °C % MSP			
0 to 2.5 bar relative pressure	0.15	0.3	1	1.2	≤ 0.1	20	40
0 to 4 bar relative pressure	0.1	0.25	0.75	0.8	≤ 0.1	25	50
0 to 6 bar relative pressure	0.1	0.25	0.75	0.8	≤ 0.1	50	60
0 to 10 bar relative pressure	0.1	0.25	0.75	0.8	≤ 0.1	50	60
0 bar to 16 bar relative pressure	0.1	0.25	0.75	0.8	≤ 0.1	120	200
0 bar to 25 bar relative pressure	0.1	0.25	0.75	0.8	≤ 0.1	120	200
0 bar to 40 bar relative pressure	0.1	0.25	0.75	0.8	≤ 0.1	300	400
0 bar to 60 bar relative pressure	0.1	0.25	0.75	0.8	≤ 0.1	300	400
0 bar to 100 bar relative pressure	0.1	0.25	0.75	0.8	≤ 0.1	300	400
0 to 0.6 bar absolute pressure	0.15	0.4	1	1.2	≤ 0.15	10	20
0 to 1 bar absolute pressure	0.15	0.3	1	1.2	≤ 0.15	10	20
0 to 1.6 bar absolute pressure	0.15	0.3	1	1.2	≤ 0.15	20	40
0 to 2.5 bar absolute pressure	0.15	0.3	1	1.2	≤ 0.1	20	40
0 to 4 bar absolute pressure	0.1	0.25	0.75	0.8	≤ 0.1	25	50
0 to 5 bar absolute pressure	0.1	0.25	0.75	0.8	≤ 0.1	25	50
0 to 6 bar absolute pressure	0.1	0.25	0.75	0.8	≤ 0.1	50	60
0 to 10 bar absolute pressure	0.1	0.25	0.75	0.8	≤ 0.1	50	60
0 to 16 bar absolute pressure	0.1	0.25	0.75	0.8	≤ 0.1	120	200
0 to 25 bar absolute pressure	0.1	0.25	0.75	0.8	≤ 0.1	120	200
0 to 40 bar absolute pressure	0.1	0.25	0.75	0.8	≤ 0.1	200	300

^a Linearity according to limit point setting

^b Reference conditions EN 61298-1

^c All measuring ranges are vacuum proof.

^d Includes: linearity, hysteresis, repeatability, deviation of measuring range start value (offset) and measuring range end value

^e Includes: linearity, hysteresis, repeatability, deviation of measuring range start value (offset) and measuring range end value, thermal effect on measuring range start (offset) and measuring span

^f MSP = measuring span

8 Technical data

8.3 Electrical data

Voltage supply ^a	
2-wire circuit ^b	
4 to 20 mA	DC 8 to 30 V, nominal voltage DC 24 V
3-wire ^c	
DC 0 to 10 V	DC 11.5 V to 30 V, nominal voltage DC 24 V
DC 1 to 5 V	DC 10 V to 30 V, nominal voltage DC 24 V
DC 1 to 6 V	DC 10 V to 30 V, nominal voltage DC 24 V

^a The auxiliary energy of the pressure transmitter must meet SELV requirements. Furthermore, the device must be equipped with an electrical circuit that meets the requirements of EN 61010-1 with regard to "Limited-energy circuits".

^b Maximum current consumption ≤ 25 mA.

^c Maximum current consumption ≤ 5 mA.

Burden/load ^a	
2-wire circuit	
4 to 20 mA	$R_L \leq (U_B - 8 \text{ V}) \div 0.02 \text{ A } (\Omega)$
3-wire	
DC 0 to 10 V	$R_L \geq 10 \text{ k}\Omega$
DC 1 to 5 V	$R_L \geq 10 \text{ k}\Omega$
DC 1 to 6 V	$R_L \geq 10 \text{ k}\Omega$

^a Maximum effect < 0.5 %.

Behavior if measured value is out of range	Error signal in the case of	NAMUR exceedance, linear
Two-wire		
4 to 20 mA	$\leq 3.6 \text{ mA}$ and $\geq 21.5 \text{ mA}$	3.8 to 20.5 mA
Three-wire		
DC 0 to 10 V	10.7 V	0 to 10.5 V
DC 1 to 5 V	5.7 V	0.8 to 5.5 V
DC 1 to 6 V	6.7 V	0.8 to 6.5 V

Behavior after power on	Ready for operation after < 120 ms
Voltage supply influence	≤ 0.02 %/V
Reverse voltage protection	U_B to 0 V (all output variants)
Short-circuit resistance	S+ to 0 V (only voltage variants)
Overvoltage protection	The operating voltage must be restricted to max. 33 V
Step response of 90 % (according to DIN 16068 Point 3.3.8)	< 5 ms

Insulation resistance	$> 100 \text{ M}\Omega$ at DC 500 V
Insulation voltage	AC 500 V

8.4 Environmental influences

Admissible temperatures	Ambient temperature	Medium temperature	Storage temperature
with MSP ^a ≤ 0.4 bar	-20 to +85 °C	-20 °C to +125 °C	-20 to +100 °C
with MSP > 0.4 bar	-40 to +85 °C ^b	-40 to +125 °C ^c	-40 to +100 °C

^a MSP = measuring span

^b Autoclave-compatible version: ≤ 140 °C for maximum 30 minutes.

^c Use in CIP/SIP processes: maximum of 140 °C for 1 h/day without being destroyed.

Use in CIP/SIP processes	The transmitter will withstand a medium temperature of 140 °C for 1 h/day without being destroyed.
Autoclave-compatible version	
Device versions	Basic type extension 045, only with round plug M12 × 1
Sterilization conditions	Complete transmitter with screwed-on protective cap
Process duration	≤ 30 minutes
Sterilization temperature	≤ 140 °C
Ambient pressure during sterilization	≤ 3.6 bar absolute
Depending on how often the CIP/SIP cleaning or the autoclaving is carried out, the long-term stability may differ from the specifications given in the table on page 18.	

Resistance to climatic conditions	100 % relative humidity including condensation on the device's outer case; 90 % relative humidity without condensation
Degree of protection	According to DIN EN 60529
Types with attached cable	IP68 ^a (IP66/IP68)
Types with round plug M12 × 1	IP67 (IP66/IP67)
Types with cable socket	IP65
Types with terminal head	IP69 (IP66/IP69)
Admissible mechanical load	
Vibration resistance	20 g at 10 to 2000 Hz, 10 cycles per axis, device in X, Y, Z axis, industrial requirement according to IEC 60068-2-6
Shock resistance	50 g for 11 ms and 100 g for 1 ms, industrial requirement according to IEC 60068-2-27
Electromagnetic compatibility (EMC)	According to DIN EN 61326-2-3
Interference emission	Class A – only for industrial use –
Noise immunity	Industrial requirements
Process media	Liquid and gaseous media which are compatible with the materials of the parts coming into contact with the pressurized medium

^a For 1 h at a depth of 2 m.

8 Technical data

8.5 Approvals and approval marks

<p>EHEDG</p> <p>Test facility</p> <p>Certificate/certification number</p> <p>Inspection basis</p> <p>Valid for</p>	<p>Research Center Weihenstephan for Brewing and Food Quality</p> <p>EL Class 1/EHEDG-C2000058</p> <p>EHEDG design specifications (doc. 8 – Hygienic Design Principles)</p> <p>Process connection 613</p> <p>Clamp DN 25, 32, 40 with Tri-Clamp seals Combifit International B.V.</p> <p>Process connection 616</p> <p>Clamp DN 50 with Tri-Clamp seals Combifit International B.V.</p> <p>Process connection 685</p> <p>VARIVENT® DN 32/25 with EPDM O-ring</p> <p>Process connection 686</p> <p>VARIVENT® DN 50/40 with EPDM O-ring</p> <p>Process connection 997</p> <p>JUMO PEKA with FKM O-ring</p>
<p>EAC</p> <p>Test facility</p> <p>Certificate/certification number</p> <p>Inspection basis</p> <p>Valid for</p>	<p>Промтехконтроль</p> <p>EAЭС N RU Д-DE.PA01.B.80830/21</p> <p>TR TS 020/2011</p> <p>All device versions</p>
<p>c UL us</p> <p>Test facility</p> <p>Certificate/certification number</p> <p>Inspection basis</p> <p>Valid for</p>	<p>Underwriters Laboratories</p> <p>E201387</p> <p>UL 61010-1 (3rd Ed.), CAN/CSA-22.2 No. 61010-1 (3rd Ed.)</p> <p>All device versions with electrical connections 36, 61 and 75</p>

						
产品组别 Product group: 402071	产品中有害物质的名称及含量 China EEP Hazardous Substances Information					
部件名称 Component Name						
	铅 (Pb)	汞 (Hg)	镉 (Cd)	六价铬 (Cr(VI))	多溴联苯 (PBB)	多溴二苯醚 (PBDE)
外壳 Housing (Gehäuse)	○	○	○	○	○	○
过程连接 Process connection (Prozessanschluss)	X	○	○	○	○	○
螺母 Nuts (Mutter)	○	○	○	○	○	○
螺栓 Screw (Schraube)	○	○	○	○	○	○
<p>本表格依据SJ/T 11364的规定编制。 This table is prepared in accordance with the provisions SJ/T 11364. ○：表示该有害物质在该部件所有均质材料中的含量均在GB/T 26572规定的限量要求以下。 Indicate the hazardous substances in all homogeneous materials' for the part is below the limit of the GB/T 26572.</p> <p>×：表示该有害物质至少在该部件的某一均质材料中的含量超出GB/T 26572规定的限量要求。 Indicate the hazardous substances in at least one homogeneous materials' of the part is exceeded the limit of the GB/T 26572.</p>						



JUMO GmbH & Co. KG

Street address:
Moritz-Juchheim-Straße 1
36039 Fulda, Germany

Delivery address:
Mackenrodtstraße 14
36039 Fulda, Germany

Postal address:
36035 Fulda, Germany

Phone: +49 661 6003-0
Fax: +49 661 6003-607
Email: mail@jumo.net
Internet: www.jumo.net

JUMO Instrument Co. Ltd.

JUMO House
Temple Bank, Riverway
Harlow, Essex, CM20 2DY, UK

Phone: +44 1279 63 55 33
Fax: +44 1279 62 50 29
Email: sales@jumo.co.uk
Internet: www.jumo.co.uk

JUMO Process Control, Inc.

6733 Myers Road
East Syracuse, NY 13057, USA

Phone: +1 315 437 5866
Fax: +1 315 437 5860
Email: info.us@jumo.net
Internet: www.jumousa.com

