

# Multi-range pressure and differential pressure transmitter



Operating Manual

40200600T90Z002K000

V2.00/EN/00761482/2021-08-30

**JUMO**



<b>1</b>	<b>General information</b>	<b>4</b>
<b>2</b>	<b>Identifying the device version</b>	<b>5</b>
2.1	Nameplate	5
2.2	Order details	5
2.3	Scope of delivery	5
2.4	Accessories	5
<b>3</b>	<b>Mounting</b>	<b>6</b>
3.1	Operating conditions	6
3.2	Dimensions	6
<b>4</b>	<b>Installation</b>	<b>7</b>
4.1	Electrical connection	7
4.2	Connection diagram	7
<b>5</b>	<b>Startup</b>	<b>8</b>
5.1	Pressure connection	8
5.2	DIP switches and push-buttons	8
5.3	Setting the measuring range	8
5.4	Setting the output signal	8
5.5	Setting the attenuation	9
<b>6</b>	<b>Calibrate</b>	<b>10</b>
6.1	Setting the zero point	10
<b>7</b>	<b>Technical data</b>	<b>11</b>
7.1	General Information	11
7.2	Output	11
7.3	Measuring range	11
7.4	Accuracy	11
7.5	Electrical data	12
7.6	Mechanical features	12
7.7	Environmental influences	12
<b>8</b>	<b>Maintenance, cleaning and returns</b>	<b>13</b>
8.1	Maintenance	13
8.2	Cleaning	13
8.3	Returns	13
<b>9</b>	<b>China RoHS</b>	<b>14</b>

---

# 1 General information

---



## CAUTION!

### Damage to device!

Do not blow into the pressure connections!

- ▶ The device may only be connected by qualified personnel.
- 

The multi-range pressure and differential pressure transmitter records pressures and converts them into a measurement signal that is proportional to the pressure. The device may only be used in the specified measuring range.

⇒ You can find further information on data sheet 402006 at [www.jumo.de/en](http://www.jumo.de/en).



## NOTE!

Do not use the device in potentially explosive areas or for measuring aggressive gases. No liability will be assumed for damage arising from improper use. Warranty claims will be void in this case.

---

JUMO GmbH & Co. KG is a company that is certified in accordance with DIN ISO 9001. The pressure transmitter described in the following complies with the requirements according to DIN and VDE.

You have purchased a product that meets stringent requirements and complies with or exceeds all the stated specifications.

If you have any reason for complaint, please return the device to us with as accurate a description as possible of the fault.

Please read this operating manual before putting the device into service.



# 3 Mounting

## 3.1 Operating conditions

The measuring instrument enables differential pressure to be measured in dry and non-aggressive gases.

The pressure transmitter is fastened to the wall using the brackets on the sides and screws and wall plugs.

Do not install the device near sources of interference (transformers, transmitters, electrical motors) or sources of heat.

Vibrations or shocks at the mounting site may lead to measurement errors.

The device has been calibrated at an ambient temperature of 20 °C, with the device upright and the process connection pointing downwards. Deviations from this installation position and ambient temperature will cause measurement errors.

## 3.2 Dimensions

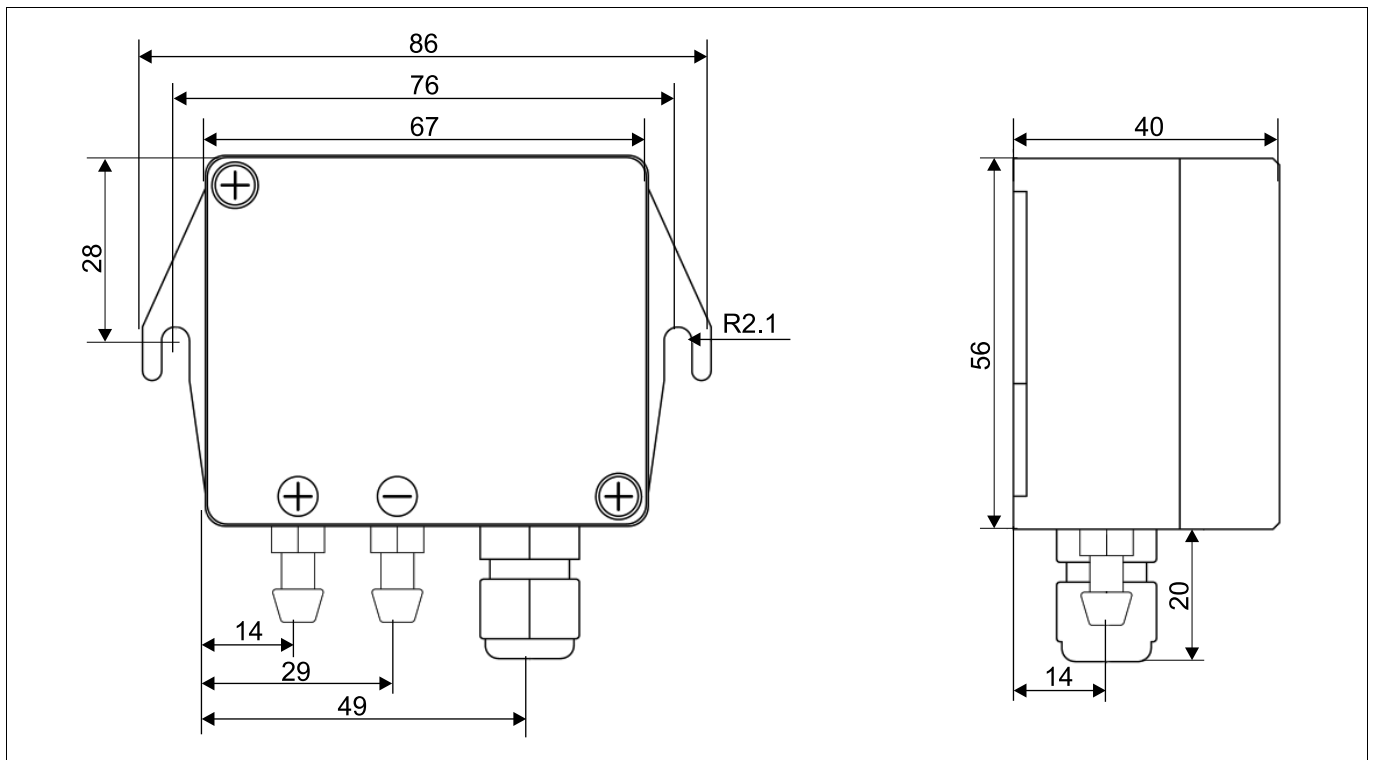

## 4.1 Electrical connection



### CAUTION!

#### Damage to device!

Do not connect the voltage supply to the terminals of the output signal!

- ▶ The device may only be connected by qualified personnel.

The regulations and safety requirements for electrical installations, low-voltage and high-voltage systems, and the regulations which apply to the country in particular (e.g. VDE 0100) must be observed.

Connect the voltage supply and the output cabling in accordance with the connection diagram.

1. Guide the lines through the cable fittings attached to the housing.
2. Connect the lines to the applicable spring-cage terminals.

*In order to ensure the specified accuracy, only put the sensor into full operation after a settling time of one hour has passed. Once the settling time has passed, perform a zero point correction (chapter 6.1 "Setting the zero point", Page 10) in order to adjust the pressure transmitter to the ambient pressure.*

## 4.2 Connection diagram

Connection		Terminal assignment
		<p>07 spring-cage terminal</p>
<b>0(4) to 20 mA, three-wire</b>		
Voltage supply DC 15 to 38 V, AC 12 to 28 V	$U_B$ 0 V/S- S+	V+ 0V/0V I
<b>DC 0(2) to 10 V, three-wire</b>		
Voltage supply DC 15 to 38 V, AC 12 to 28 V	$U_B$ 0 V/S- S+	V+ 0V/0V U

# 5 Startup

## 5.1 Pressure connection

1. Connect the hose with the higher pressure to "+".
2. Connect the hose with the lower pressure to "-".

## 5.2 DIP switches and push-buttons

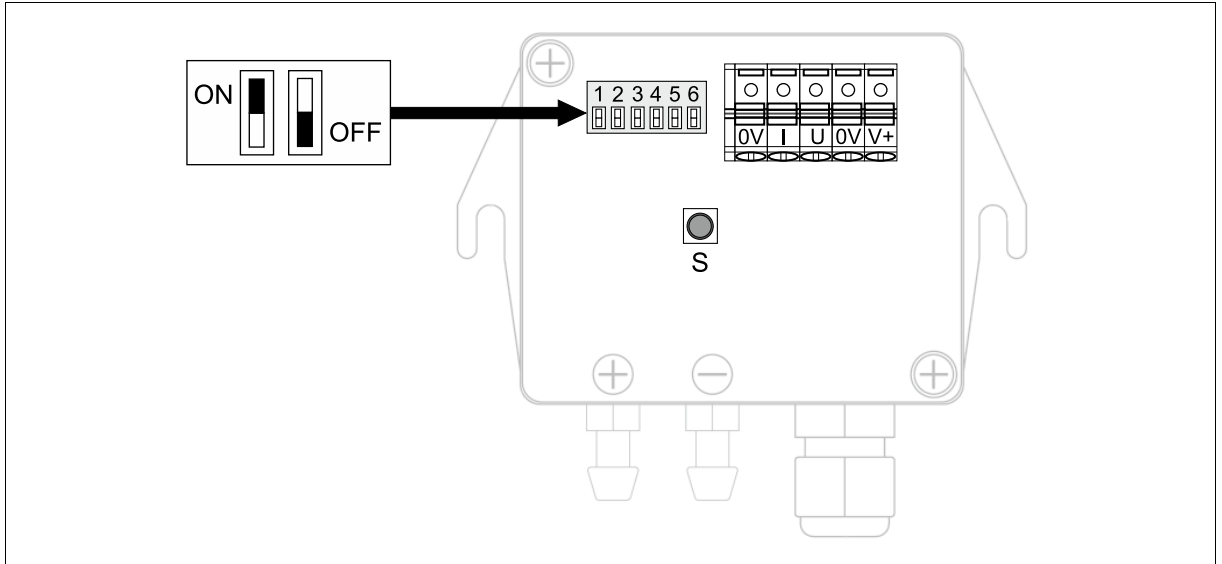

## 5.3 Setting the measuring range

Basic measuring range 10 hPa	Position		
	S1	S2	S3
Measuring range			
0 to 10 hPa	Off	Off	Off
0 to 7.5 hPa	On	Off	Off
0 to 5.0 hPa	Off	On	Off
0 to 2.5 hPa	On	On	Off
-10 to +10 hPa	Off	Off	On
-7.5 to +7.5 hPa	On	Off	On
-5.0 to +5.0 hPa	Off	On	On
-2.5 to +2.5 hPa	On	On	On

Basic measuring range 100 hPa	Position		
	S1	S2	S3
Measuring range			
0 to 100 hPa	Off	Off	Off
0 to 75 hPa	On	Off	Off
0 to 50 hPa	Off	On	Off
0 to 25 hPa	On	On	Off
-100 to +100 hPa	Off	Off	On
-75 to +75 hPa	On	Off	On
-50 to +50 hPa	Off	On	On
-25 to +25 hPa	On	On	On

## 5.4 Setting the output signal

Output signal	Position S4
0 to 10 V/0 to 20 mA	Off
2 to 10 V/4 to 20 mA	On



### 5.5 Setting the attenuation

Time constant	Position S5	Position S6
50 ms	Off	Off
500 ms	On	Off
2000 ms/2 s	Off	On
4000 ms/4 s	On	On

# 6 Calibrate

---

## 6.1 Setting the zero point

1. Detach both pressure hoses from the device.
2. Open the device.
3. Press the "S" button.
4. Close the device.
5. Re-connect the pressure hoses to the device.

Over time, the position of the zero point of a pressure sensor moves due to external influences and the nature of the piezoresistive sensor element. We therefore recommend that you perform a zero point correction before startup and then at annual intervals.



**DANGER!**

### **Risk of electric shocks!**

Risk of severe injury upon contact with live parts.

- ▶ Before working on the open device, disconnect the voltage supply or take suitable protective measures.
-

## 7.1 General Information

Reference conditions	DIN 16086 and DIN EN 60770
Sensor	
Measuring principle	Silicon sensor (piezoresistive)
Measurement medium	Non-aggressive gases
Mounting position	Device upright, process connection at the bottom
Calibration position	Device upright, process connection at the bottom

## 7.2 Output

Analog output	Can be configured using DIP switch DC 0 to 10 V, three-wire (standard), DC 2 to 10 V, three-wire, 0 to 20 mA, three-wire (standard), 4 to 20 mA, three-wire
Attenuation	Can be configured using DIP switch 50 ms (standard), 500 ms, 2000 ms, 4000 ms
Burden	
Current	
0(4) to 20 mA, three-wire	At a voltage supply of 15 to 18 V $R_L \leq 300 \Omega$ From a voltage supply of 18 V $R_L \leq 500 \Omega$
Voltage	
DC 0(2) to 10 V, three-wire	$R_L \geq 2 \text{ k}\Omega$

## 7.3 Measuring range

	Basic measuring range 1	Basic measuring range 2
Measuring range start	You can choose whether the measuring ranges begin at 0 hPa or the inverted measuring range (configurable).	
Measuring range (standard)	0 to 10 hPa	0 to 100 hPa
Measuring range (configurable)	0 (-2.5) to 2.5 hPa, 0 (-5) to 5 hPa, 0 (-7.5) to 7.5 hPa, 0 (-10) to 10 hPa	0 (-25) to 25 hPa, 0 (-50) to 50 hPa, 0 (-75) to 75 hPa, 0 (-100) to 100 hPa
Overload capability	100 hPa	800 hPa
Burst pressure	150 hPa	1000 hPa

## 7.4 Accuracy

Overall accuracy	1% of the basic measuring range end value (10 hPa or 100 hPa) The accuracy specified includes the largest possible error at room temperature.
Long-term stability	< $\pm 0.1\%$ of the basic measuring range end value (10 hPa or 100 hPa) per year Reference conditions according to DIN EN 61298-1
Temperature drift	< $\pm 0.05\%$ of the basic measuring range end value (10 hPa or 100 hPa) per K

## 7 Technical data

---

### 7.5 Electrical data

Voltage supply $U_B$	DC 15 to 38 V, AC 12 to 28 V Residual ripple: the voltage peaks must not exceed or fall below the specified voltage supply values!
Current consumption	Approx. 15 mA (without load)
Electrical connection	5-pole spring-cage terminal, max. 2.5 mm <sup>2</sup> conductor cross section
Reverse voltage protection	Yes
Electrical circuit Requirement	SELV The device must be equipped with an electrical circuit that meets the requirements of EN 61010-1 with regard to "Limited-energy circuits".

### 7.6 Mechanical features

Material Parts in contact with media	Si, Al, Au, Cu, Ni, Pd, EP, PC, ABS
Housing Dimensions	86 mm × 56 mm × 40 mm (H × W × D)
Pressure connections	Dia. 6.6 mm × 10 mm (for flexible hoses dia. 6 mm)
Cable fittings	M12 × 1.5
Display (optional)	Plug-in LCD display, 3.5-digit (separate accessory)
Weight	100 g

### 7.7 Environmental influences

Admissible temperatures Medium	0 to 60 °C
Environment	0 to 60 °C
Storage	-20 to +70 °C
Admissible humidity	< 95% relative humidity (non-condensing)
Ambient pressure	600 to 1200 hPa
Admissible mechanical load Vibration resistance	Upon request
Shock resistance	100 g for 6 ms, according to DIN EN 60068-2-27
Electromagnetic compatibility (EMC) Interference emission	Class B <sup>a</sup> , according to DIN EN 61000-6-3
Interference immunity	Industrial requirement, according to DIN EN 61000-6-2
Protection type	IP54, according to DIN EN 60529

<sup>a</sup> The product is suitable for industrial use as well as for households and small businesses.

# 8 Maintenance, cleaning and returns

---

## 8.1 Maintenance

Over time, the position of the zero point of a pressure sensor moves due to external influences and the nature of the piezoresistive sensor element. We therefore recommend that you perform a zero point correction before startup and then at annual intervals.

Beyond this, the pressure transmitter is maintenance-free.

## 8.2 Cleaning



### NOTE!

**Avoid damage to the device due to improper cleaning.**

Do not damage the pressure transmitter, in particular the parts that come into contact with media. The cleaning agent must not attack the surface or seals.

---

## 8.3 Returns



### WARNING!

**Personal injury, property damage, environmental damage**

Residual medium on the removed product can cause damage to persons, the environment and equipment.

► Take adequate precautionary measures.

---



### NOTE!

The device may only be disassembled in a safe and voltage-free state of the plant by qualified personnel.

---



### NOTE!

All information necessary for return is included in the [Supplementary sheet for product returns](#).

---

## 9 China RoHS

						
产品组别 Product group: 402006	产品中有害物质的名称及含量 <b>China EEP Hazardous Substances Information</b>					
部件名称 Component Name	铅 (Pb)	汞 (Hg)	镉 (Cd)	六价铬 (Cr(VI))	多溴联苯 (PBB)	多溴二苯醚 (PBDE)
外壳 Housing (Gehäuse)	○	○	○	○	○	○
过程连接 Process connection (Prozessanschluss)	○	○	○	○	○	○
螺母 Nuts (Mutter)	○	○	○	○	○	○
螺栓 Screw (Schraube)	○	○	○	○	○	○

本表格依据SJ/T 11364的规定编制。  
 This table is prepared in accordance with the provisions SJ/T 11364.  
 ○：表示该有害物质在该部件所有均质材料中的含量均在GB/T 26572规定的限量要求以下。  
 Indicate the hazardous substances in all homogeneous materials for the part are below the limit of the GB/T 26572.  
 ×：表示该有害物质至少在该部件的某一均质材料中的含量超出GB/T 26572规定的限量要求。  
 Indicate the hazardous substances in at least one homogeneous material of the part exceed the limit of the GB/T 26572.





**JUMO GmbH & Co. KG**

Street address:  
Moritz-Juchheim-Straße 1  
36039 Fulda, Germany

Delivery address:  
Mackenrodtstraße 14  
36039 Fulda, Germany

Postal address:  
36035 Fulda, Germany

Phone: +49 661 6003-0  
Fax: +49 661 6003-607  
Email: [mail@jumo.net](mailto:mail@jumo.net)  
Internet: [www.jumo.net](http://www.jumo.net)

**JUMO Instrument Co. Ltd.**

JUMO House  
Temple Bank, Riverway  
Harlow, Essex, CM20 2DY, UK

Phone: +44 1279 63 55 33  
Fax: +44 1279 62 50 29  
Email: [sales@jumo.co.uk](mailto:sales@jumo.co.uk)  
Internet: [www.jumo.co.uk](http://www.jumo.co.uk)

**JUMO Process Control, Inc.**

6733 Myers Road  
East Syracuse, NY 13057, USA

Phone: +1 315 437 5866  
Fax: +1 315 437 5860  
Email: [info.us@jumo.net](mailto:info.us@jumo.net)  
Internet: [www.jumousa.com](http://www.jumousa.com)

